

Study and optimization of a parallel hydraulic hybrid system for heavy vehicles

Camilla Di Lorenzo¹, Nicola Andretta¹, Antonio Rossetti², and Alarico Macor^{1,*}

¹Department of Engineering and Management - Stradella San Nicola 3- 36100 Vicenza

²CNR- Istituto per la Tecnologia della Costruzione - Corso Stati Uniti, 4 - 35127 Padova.

Abstract. The parallel hydraulic hybridization, thanks to its simplicity and high specific power, is a suitable solution for the retrofitting of off-highway vehicles subject to work cycles with frequent stop-and-go. This work is focused on the potential of the low-cost parallel hybrid solutions, i.e. characterized by current-technology components, for a specific class of heavy vehicles: city buses. After functional sizing, the hybrid vehicle was modelled and simulated in the Amesim environment. The comparison with the non-hybridized reference vehicle highlighted an interesting consumption reduction, which in any case varies with the type of route. Finally, an optimization of the hybrid vehicle was carried out by means of genetic algorithms, which led to a further, and not negligible, consumption reduction compared to the hybridized version. Optimization, therefore, can be seen as a tool to overcome those minimum benefit thresholds that manufacturers consider as necessary for the industrialization and marketing of new energy recovery systems.

1 Introduction

Electric hybridization is definitely spreading in the automotive sector, driven by the need to reduce consumptions and emissions. The off-highway sector has also recently considered electric hybridization. However, the high costs and low specific powers of the batteries have limited hybridization to low power machines.

Hydraulic hybridization, on the other hand, thanks to its high specific power and high efficiency in the reuse of recovered energy, seems to be more suitable for off-road machines, especially those subject to work cycles with frequent stop-and-go. Furthermore, hydraulic hybridization is based on mature technology and not particularly complex equipment, which lead to quite low investment and maintenance costs compared to the electric hybridization.

The hydraulic hybrid solutions are the well-known series, parallel and power split, which are schematized in Fig. 1.

* Corresponding author: alarico.macor@unipd.it

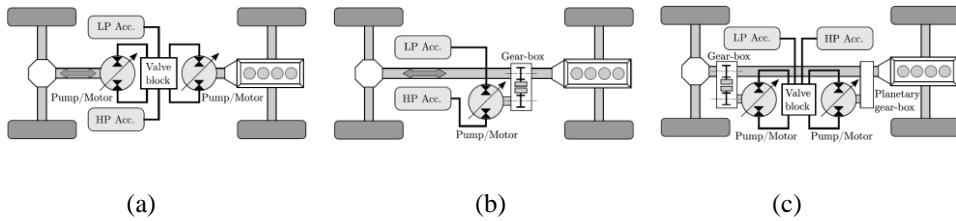

Fig. 1. Schemes of series (a), parallel (b), and power-split (c) hydraulic hybrid solutions.

The power-split solution is still the subject of scientific investigation, and although the first results seem encouraging, prototypes have not yet been produced.

The series solution shows better performance than the parallel one, but has a greater complexity [1]. The first solution is a transmission that fully replaces the traditional one, and can also have the engine controlled according to minimum consumption. The second one is only a hydraulic system capable of recovering and reusing the kinetic energy of the vehicle during braking. Kargul [1] studied these two solutions, built the prototypes and tested them on the bench and on the road: a parallel prototype for Ford-550 truck (6500 kg), recorded fuel economy increases of 20-30% in urban paths; the series prototype obtained increases up to 170% on the test bench.

This work aims at investigating the potential of the parallel hybrid solution, with particular interest in low-cost solutions, i.e. with commercial, unsophisticated, and inexpensive components. The study is aimed at a specific class of heavy vehicles: city buses. The motivations behind the work lie in the interesting performances, even if not the maximum ones, and in the mature technology, which produces low construction and maintenance costs. Furthermore, the parallel solution can be adopted in new vehicles and easily retrofittable in conventional vehicles.

In the literature, the parallel hydraulic hybrid solution has been present since the 1970s [2]. After the configuration proposed by EPA in 2003 [1] and by Eaton in [3], attributable to the diagram in Fig. 1, in 2009 a more complex configuration was presented [4], having an auxiliary variable displacement pump for recharging the accumulator; in this way the disadvantage of the low energy density typical of the hydraulic hybrid system is reduced. In this configuration the internal combustion engine (ICE) can be managed in conditions of maximum efficiency. The new configuration has also been studied to define a braking control in compliance with the ECE (Economic Commission of Europe) requirements [5]. In [6] another new parallel hydraulic hybrid configuration has been proposed which, however, provides for a substantial modification of traditional transmission. The solution presented in [7] summarizes the series and the parallel and involves the use of a constant pressure rail, a system which, by means of a hydraulic transformer, keeps the pressure in the high pressure line constant by adjusting the flow rate to the accumulator as required by the load.

In [8, 9] a simple configuration is proposed, whose sizing is a compromise between performance and cost. Fuel savings can be up to 30%. In a recent study, [10], a parametric design of the hydraulic hybrid system was carried out, with reference to a heavy vehicle and based on the power demand in different urban cycles. It is concluded that, in order to achieve maximum benefits, the parameters of the hydraulic system must be designed according to the characteristics of the vehicle and the working conditions. It is worth noting that the research is not only aimed at buses, but also at trucks [11, 12], military vehicles [13, 14], refuse collection vehicles [15] and delivery vehicles [16]. An example is the

PDRMES (Permo Drive Regenerative Energy Management System) which in [13] is applied to a military vehicle.

The study of a parallel hybrid system, however, cannot be limited to a functional design, since performance and fuel consumption are strongly influenced by the size of the components (pump/motor displacement, accumulator volume, operating pressure and transmission ratio of the connecting gear) and the management criteria of the system itself: a choice based on empirical considerations may not lead to completely satisfactory results. For this reason, the project must be configured as an optimization problem capable of finding the values of the design parameters that lead to lower energy consumption in compliance with the functional constraints of the vehicle. The present work, therefore, was developed in three different steps. The first step was the identification of the most efficient layout for the hydraulic system among the simple ones proposed by the literature, along with the management criteria of the two energy sources. Once these choices were made, the reference vehicle, an urban bus, and the hydraulic system were sized, modelled and simulated in Amesim [17] to verify the extent of energy savings and the vehicle's ability to operate according to standard cycles for buses. Finally, still in the same computing environment, the most important design parameters were optimized, solving the energy consumption minimization problem through a genetic algorithm. This last step showed further, and not negligible, energy savings with respect to those obtained with the functional sizing alone.

1.1 Reference vehicle

The reference vehicle taken for this study is a 12 m class city bus, the main characteristics of which are shown in Table 1.

Table 1. Reference vehicle data.

Allowable gross mass	19000 kg
Engine	Cursor 9 EURO VI
Type	Inline-six engine, common rail
Max power	265 kW (360CV) at 2200 rpm
Automatic gearbox	ZF Ecolife con TOPODYN LIFE
Differential gear ratio	5.73
Wheels and tyres	275/70 R22.5

2 Layouts

In a preliminary analysis, the most suitable layout was identified among those proposed by the literature, shown in Fig. 2.

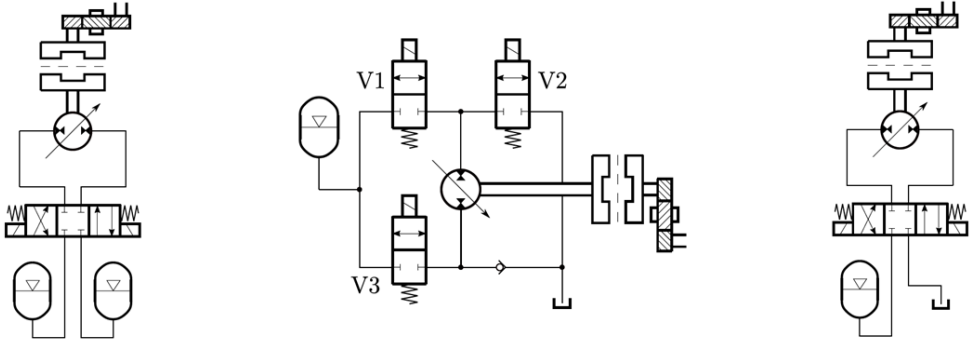

Fig. 2. Layouts of the parallel hydraulic systems.

The three layouts were sized on the basis of the reference vehicle data, assuming as a design speed the maximum in urban routes, typically 60 km/h. The gear ratio i of the gear reducer descends from this speed. Through equation (1) the maximum storable energy E_{max} is established and, consequently, the volume of the accumulator calculated assuming $p_{max} = 400$ bar the maximum pressure, and a polytropic coefficient $k = 1.4$.

$$E_{max} = p_{min} V_{min} / (k-1) \cdot [(p_{min}/p_{max})^{(1-k)/k} - 1] \geq mv^2/2 \quad (1)$$

Once the volume of fluid processed by the accumulator $\Delta V = V_{max} - V_{min}$ is known, the maximum flow rate of the pump/motor Q_{max} can be determined through equation (2), by imposing a deceleration time T_d . Finally, the displacement V of the pump/motor is calculated through equation (3).

$$\Delta V = \frac{1}{2} Q_{max} T_d \quad (2)$$

$$Q = V n \eta_v \quad (3)$$

where n and η_v are respectively the rotational speed and the volumetric efficiency of the motor/pump.

In summary, the design values of the three hydraulic systems are: $p_0/p_{min} = 0.87$ e $p_{max}/p_{min} = 3.48$, $i = 2.61$, $V_0 = 50$ l, $V = 90$ cm³.

The three layouts can work in two different modes. In the first one (in the following MODE1), during the acceleration phases, only the hydraulic system supplies power to the vehicle; when the accumulator is no longer able to support the torque required by the vehicle, the engine comes into action; during regenerative braking, first the hydraulic system brakes the vehicle by recharging the accumulator up to its maximum pressure, then the mechanical brakes intervene. In the second mode (MODE2), both the engine and the hydraulic system work simultaneously.

In both modes, the control system acts on the displacement adjustment of the pump / motor, on the clutch, and on the position of the directional valve.

The reference vehicle was modeled and simulated in order to compare the performance of the three layouts based on the energy required by the engine. A trapezoidal speed profile was applied to the model, with acceleration and deceleration typical of a city route, respectively equal to 0.5 m/s² and 1 m/s², and a maximum speed of about 60 km/h.

The energies required to the engine by the three layouts are compared in Table 2. The second layout is the most efficient one, for both management criteria. The third layout, however, only has 2% lower performance than the second one, and has fewer components

and a simpler management criterion, having to control only the clutch, hydraulic machine and distributor. For this reason, it will be adopted in the analyzes that will follow. The management criterion, as will be seen below, will be a combination of the previous two.

Table 2. ICE output energy of the three layouts. The deviations are compared with the corresponding control logic of Layout 2.

Energy [kWh]	Layout 1		Layout 2		Layout 3	
	MODE1	MODE2	MODE1	MODE2	MODE1	MODE2
ICE	0.4599	0.4720	0.4302	0.4394	0.4395	0.4406
Difference	6.90%	7.42%	-	-	2.16%	0.30%

3 Model

The reference vehicle and the new hybrid vehicle were modelled and simulated in Amesim. Figure 3 shows the diagram of the first of the two models. The element depicted with the bus icon describes the motion resistance of the vehicle, including inertia; the driver is modelled as a PID controller which imposes a predetermined speed profile on the vehicle and sends signals to the brake and accelerator pedal. The Cursor 9 engine consumption map has been included in the ICE model.

The six-speed automatic gearbox is preceded by the torque converter, which was modelled according to the classical dimensionless parameters: the power factor and the torque ratio, both as a function of the speed ratio.

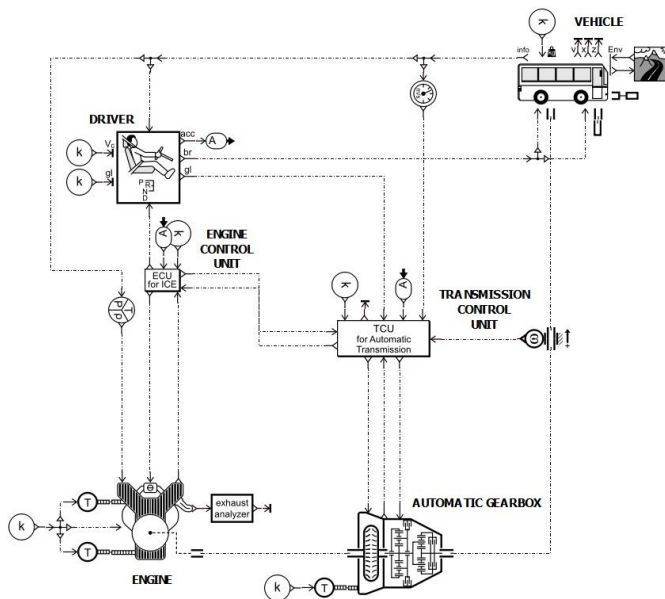

Fig. 3. Reference vehicle diagram.

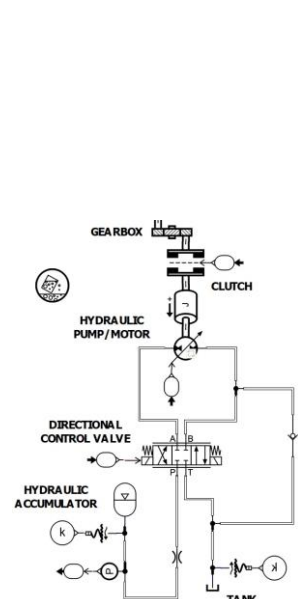

Fig. 4. Braking recovery system diagram.

The braking energy recovery system (Fig. 4) is located downstream of the automatic gearbox and connected to the transmission axis via a gear and a clutch. The pump/motor and directional control valve have been modelled taking into account their real operating losses provided by the manufacturer. To take account of the accumulator's own losses, an orifice equivalent to the inlet valve was added. The one-way valve in parallel to the distributor avoids cavitation when the hydraulic machine works as a pump during braking.

The system uses a VG 32 oil (kinematic viscosity of 32 cSt at 40 °C) characterized by a density of about 870 kg/m³. A preliminary analysis of the system showed that the oil temperature reaches 100 °C after two hours of operation with the Manhattan test cycle. Therefore, a forced convection cooling system was set up, which allowed the oil to reach the operating temperature of 50 °C in about 4 hours, with an ambient temperature of 20 °C.

3.1 Control logic

Figure 5 shows the block diagram of the control logic, whose inputs are: vehicle speed, acceleration, torque required by the powertrain, and the pressure in the accumulator. From these signals, the torque provided by the hydraulic system, and the torque the ICE or the mechanical brake must deliver are obtained. These two values combine together in order to follow the reference speed profile as closely as possible, and meet the driver's total torque demand. The torque required from the vehicle's conventional transmission regulates the accelerator and brake control, while the torque required from the hydraulic system acts on three elements of the braking energy recovery system: clutch, pump/motor displacement, and distributor position.

Figure 6 shows the block diagram of the hydraulic system control logic. The hydraulic system is activated only if:

- the vehicle speed v is between the minimum and maximum speed set in accordance with the speed of the pump/motor and the reduction gear ratio;
- the accumulator pressure p is between the minimum and maximum values;
- the braking intensity z is lower than a set limit.

The torque required by the vehicle (T_{req}) and the torque available by the hydraulic system (T_{hyd}) for $\alpha = 1$ then enter the control.

$$T_{hyd} = V\Delta p / (2\pi) \quad (4)$$

When T_{req} is less than or equal to T_{hyd} the hydraulic system is able to supply or deliver energy and autonomously satisfy the torque request. In this case the standard vehicle transmission does not work, and the torque required from the hydraulic system (T_{reg}) is equal to:

$$T_{reg} = T_{req} \quad (5)$$

On the other hand, if T_{req} is greater than T_{hyd} , the hydraulic system is not able to autonomously satisfy the driver's request. In this condition the hydraulic system delivers flow up to the minimum pressure of the accumulator, or receives flow up to full charge, in the case of braking; the missing torque is provided by the ICE or mechanical brakes ($T_{MCI/br}$). In this case T_{reg} is given by:

$$T_{reg} = T_{hyd} \quad (6)$$

It should be noted that the operation of the mechanical and hydraulic system is no longer linked with MODE1 or MODE2, but it is a combined mode based on the total torque request and the availability of energy in the accumulator.

To determine the motor/pump displacement adjustment (α), the value of T_{reg} is observed. Only if this is greater than an imposed minimum value (T_{min}) the value of α will be different from zero. This parameter is determined as the ratio between the torque required by the hydraulic system and that available from it.

The activation of the clutch (fri) and the distributor occurs only if the value of α exceeds a minimum value set (α_{min}): this choice is motivated by the poor performance of the pump/motor due to small displacements.

To determine the correct position of the distributor, the accelerator (acc) and brake (br) signals are considered in order to determine whether the vehicle is moving forward or braking.

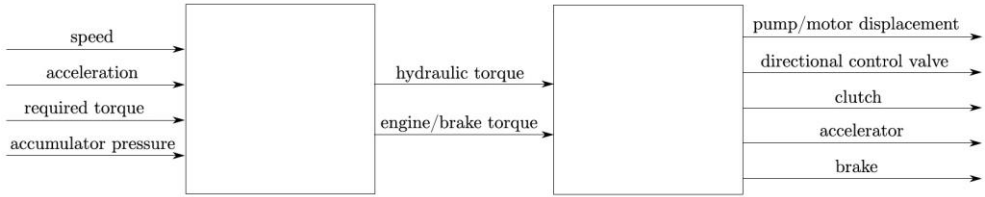

Fig. 5. Block diagram of the vehicle control logic.

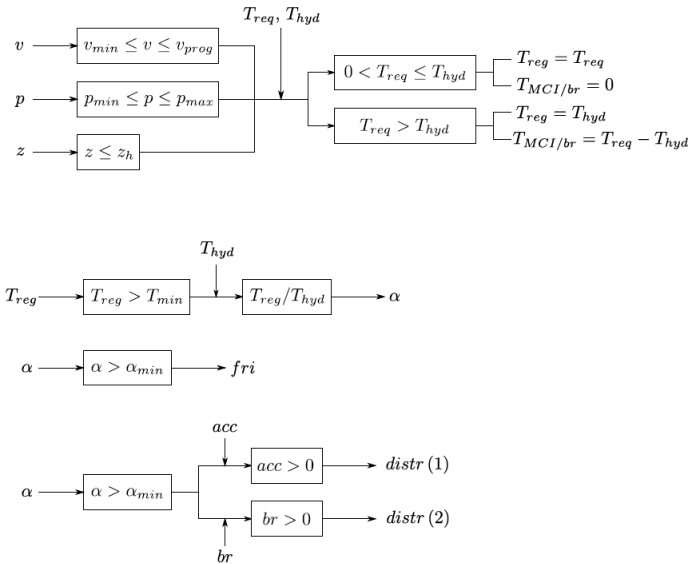

Fig. 6. Block diagram of the hydraulic system control logic.

4 Simulations and results

The reference vehicle model and the hybrid vehicle model were simulated on some standard bus speed profiles: Manhattan, WLTC and CUEDC cycles [18]. Some parts of the last two cycles, which more faithfully represent the operation of an urban bus, were also used. Figure 7 shows a short section of the CUEDC - Congested cycle and the trends provided by the simulation of the main variables involved.

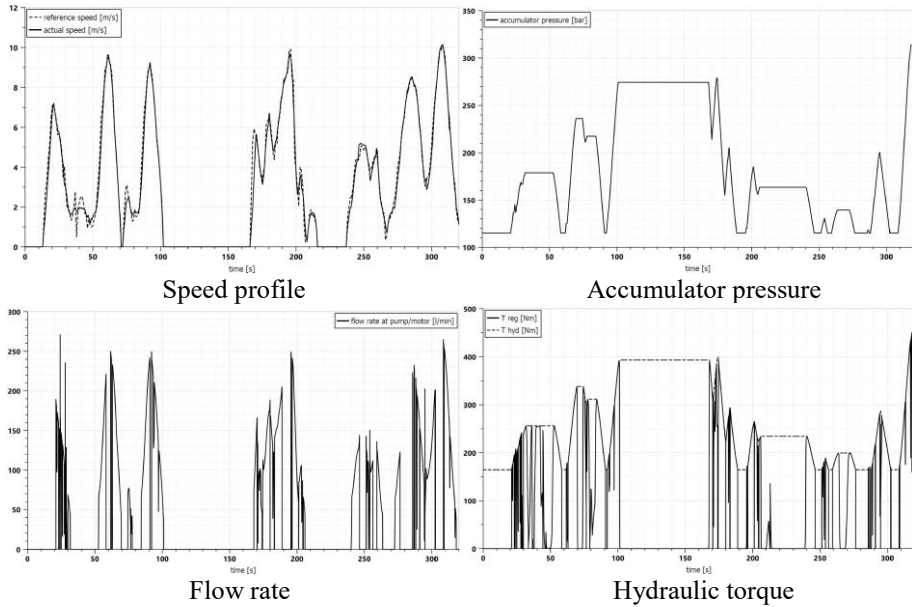

Fig.7. CUEDC cycle: speed profile and simulated variables of the hydraulic system.

Table 3 shows the main simulation results of the reference vehicle, such as: the output energy of the ICE, the fuel consumption and the value of the Root-Mean-Square Error (RMSE) of the speed profile. The third parameter provides a numerical indication of how much the real vehicle speed differs from the ideal reference speed along the entire speed profile. The high error on the WLTC cycle is caused by the power deficit of the engine.

Table 3. Simulation results of the reference vehicle.

Standard test cycle	ICE energy [kWh]	Fuel consumption [g]	RMSE [m/s]
Manhattan	13.3565	3182.71	0.32
WLTC	49.3020	11087.20	1.05
WLTC: Low	8.2351	1950.55	0.26
WLTC: Low – Medium	19.4144	4448.63	0.38
CUEDC	35.1183	7960.53	0.66
CUEDC: Congested	4.1761	985.44	0.39
CUEDC: Congested – Res/Minor	15.3623	3523.35	0.42

Afterwards, the hybrid vehicle was simulated on the same standard cycles. Table 4 shows the main simulation results in terms of ICE output energy and energy input (i.e. regenerated during regenerative braking) and output (i.e. given back to the driveline during acceleration phases) of the hydraulic system. The ratio between these last two quantities determines the efficiency of the hydraulic system, which varies from 52% to 69%

depending on the cycle. It should be noted that considering the Congested section of the CUEDC test cycle, that is a road profile that represents the actual operation of the vehicle in question, the fuel saving can exceed 20%.

Table 4. Simulation results for hydraulic hybrid vehicle. HS stands for hydraulic system.

Standard test cycle	ICE en. [kWh]	HS input en. [kWh]	HS output en.[kWh]	HS efficiency [%]	ICE energy saving [%]
Manhattan	11.0896	2.1026	1.4027	66.71	16.97
WLTC	47.1491	2.2348	1.5425	69.02	4.37
WLTC: Low	6.9095	1.0426	0.6878	65.97	16.10
WLTC: Low – Medium	17.5854	1.7227	1.1056	64.18	9.42
CUEDC	31.4762	3.4426	2.3015	66.85	10.37
CUEDC: Congested	3.3081	0.7419	0.3896	52.51	20.78
CUEDC: Congested – Res/Minor	13.0095	2.1133	1.3726	64.95	15.32

5 Optimization

5.1 Mathematical formulation

The optimization problem is generally stated as follows

$$\begin{aligned} & \min \{f(x) : x \in \Omega\} \\ & \text{subject to } g(x) \leq 0 \end{aligned} \quad (7)$$

Where x is the vector of the decision variables contained in the search space Ω , $f(x)$ is the objective function to be minimized and $g(x)$ are the constraint equations. In the problem under consideration, the mechanical energy delivered by the ICE is considered as the objective function, while the decision variables are chosen based on the element to be optimized.

The search for the optimum was carried out using the technique of genetic algorithms. This type of algorithm is placed in pseudo-stochastic methods, suitable for cases in which the objective function or the search space does not satisfy properties of continuity, or cases in which the gradient is difficult to calculate.

5.2 Optimization subproblems

In order to determine the parameters that most influence energy saving, two optimization subproblems have been solved: the first one is limited to the decision variables relating to the pump/motor and gear reducer, the second is limited to the decision variables relating to the accumulator.

5.2.1 1st optimization subproblem: pump/motor-reducer group.

The variables are the displacement V and the gear ratio i of the reducer.

While the transmission ratio is free to vary within a wide range around the design value, the displacement varies by discrete values, according to the catalogue values of a manufacturer shown in Table 5.

It is observed that as the displacement increases, the maximum speed of the reversible machine decreases and, consequently, the maximum speed above which the system cannot be used. The displacement of the reversible machine influences the maximum flow rate that circulates in the system and consequently also the size of the distributor. Furthermore, the different pump and distributor sizes mean a different mass added to the original vehicle: all these aspects have been considered in the model.

Table 6 shows the optimal values of the decision variables obtained on the CUECD Congested test cycle. The further increase in energy savings, compared to the non-optimized model, is 4.4%.

5.2.2 2nd optimization subproblem: accumulator

The decision variables are the accumulator volume V_0 and the ratios p_0/p_{min} and p_{max}/p_{min} between the characteristic pressures. The maximum pressure was assumed to be equal to that of the class chosen in the catalogue. Both the weight of the accumulators and the weight of oil circulating in the system were accounted for.

Table 6 shows the optimal values of the two subproblems, limited to the CUECD Congested test cycle. The optimal solution shows an increase in the energy saving, compared with the non-optimized case, of 3.8%. It is concluded that the accumulator and the pump/motor-reducer group can be considered as elements of equal importance in relation to the efficiency of the recovery system.

Table 5. Discret values of the design variables.

Accumulator volume [l]	32, 40, 50, 64, 80, 100
Pump/motor displacement [cm ³] / n max [g/min]	56/3900, 71/3600, 90/3350, 110/3300, 125/3250

Table 6. Results of the optimization of the subproblems with CUECD Congested test cycle.

Subproblem	Optimal value	Increase in energy saving
Pump/motor and gearbox	$V = 125 \text{ cm}^3$	4.4%
	$i = 2.87$	
Accumulator	$V_0 = 50 \text{ l}$	3.8%
	$p_0/p_{min}=0.80$	
	$p_{max}/p_{min}=2.06$	

5.2 Global optimization

Finally, a global optimization was carried out on the CUECD Congested test cycle, considering as decision variables the five ones defined in the two previous subproblems. Figure 8 shows the values of the decision variables taken during the iterative process of the genetic algorithm. The optimal solution of the optimization problem leads to an increase in energy saving, compared to the non-optimized model, of 4.78%. This value compared with the values obtained in the previous subproblems highlights the strong interdependence between the two subsystems.

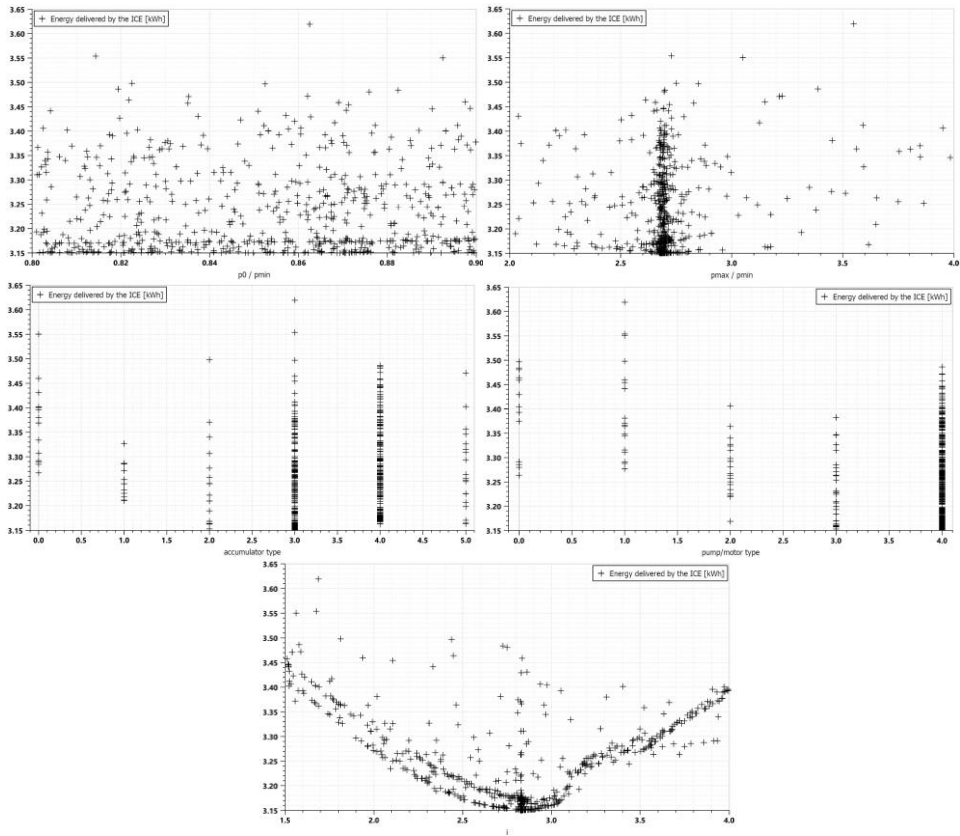

Fig.8. Values of the decision variables during the iterative process of the genetic algorithm. The accumulator volumes are 32 l (0), 40 l (1), 50 l (2), 64 l (3), 80 l (4), and 100 l (5) while the pump/motor displacements are 56 cm³ (0), 71 cm³ (1), 90 cm³ (2), 110 cm³ (3), and 125 cm³ (4).

5.3 Final remarks

The optimization problem was also carried out for the other test cycles. About the optimal values of the decision variables, reported in Table 7, the following conclusions can be drawn.

- The values of the p_0/p_{\min} ratio are almost constant, confirming the traditional practice of considering this ratio as constant and equal to 0.85-0.9.
- Even the p_{\max}/p_{\min} ratio does not vary markedly with the test cycle, bringing the minimum pressure of the accumulator to vary between about 140 and 160 bar.
- While the optimizer tends to increase the pump displacement as much as possible, in order to recover more braking energy, it stops at 64 liters for the accumulators. This different behavior is due to the different weight of the accumulators and the pump. While the latter has a low weight even at high displacements, the weight of the two accumulators is high and grows with their volume.

The gear ratio i is the only variable affected by the test cycle, in particular by its average speed. In fact, i determines the speed below which the recovery braking takes effect, cutting out the higher speeds.

The last two columns of Table 7 show the energy savings. The first column reports the savings induced by the optimization, that is, the difference between the ICE output energy in the simple hybrid vehicle and the same energy in the optimized hybrid vehicle. The second column shows the energy saving achieved by the optimized hybrid vehicle compared to the reference vehicle.

Thanks to the optimization, the energy saving increases by 2-5%, while compared to the reference vehicle the saving increases by 6-24%. The greatest benefit is obtained with the CUEDC test cycle in the Congested section, precisely the route that most carefully represents the operation of a city bus.

Finally, Table 8 shows the energy savings and the increase in fuel economy obtained from the hybrid vehicle in the optimal CUEDC-congested configuration subjected to the other cycle tests. The savings are obviously lower than those of the last column in Table 7, on average by 1.5%, but still interesting. It is noted that the fuel economy increases are equal to or slightly higher than that detected by [1] on bench tests with standard cycles.

The economic savings achievable with the parallel solution can now be estimated. Considering that in the congested CUEDC route the consumption is 0.985 kg (Table 3), equal to 1.18 l, and that the length of the route is 3.291 km, the fuel economy of the base vehicle is equal to 2.7 km/l. Assuming an average mileage of 30,000 km/year, with 1 €/l the cost of diesel, the optimized CUEDC congested solution would produce an annual fuel cost saving of 2730 €, which extended to a vehicle life cycle of 10 years becomes 27 300 €.

In summary, for the vehicle considered here, hydraulic hybridization involves a fuel saving of about 20%; the optimization of the hydraulic energy recovery system leads to an additional saving of 4-5%. Hence the importance of optimization as a design tool.

Table 7. Optimization results with different standard cycles.

Standard test cycle	p_0/p_{min}	p_{max}/p_{min}	V_0 [l]	V [cm ³]	i	Energy saving Optimized hybrid – baseline hybrid	Energy saving Optimized hybrid – reference vehicle
Manhattan	0.84	2.80	64	125	2.60	3.80 %	20.13 %
WLTC	0.89	2.71	64	110	1.92	2.06 %	6.34 %
WLTC: Low	0.90	2.40	64	110	2.32	3.58 %	19.10%
WLTC: Low – Medium	0.89	2.60	64	125	1.86	3.93 %	12.98 %
CUEDC	0.90	2.82	64	125	2.14	2.23 %	12.37 %
CUECD: Congested	0.87	2.68	64	125	2.83	4.78 %	24.57 %
CUECD: Congested – res/Minor	0.89	2.48	64	110	2.47	3.61 %	18.37%

Table 8. Simulated performance of the hybrid vehicle in CUECD Congested configuration on the various standard cycles.

Standard test cycle	Energy saving Optimized hybrid CUEDC – reference vehicle	Increase in fuel economy (km/l) Optimized hybrid CUEDC – reference vehicle
Manhattan	19,00%	23,5%
WLTC	4,48%	4,7%
WLTC: Low	16,89%	20,3%
WLTC: Low – Medium	11,43%	12,9%
CUEDC	10,79%	12,1%
CUECD: Congested	24,57%	32,57%
CUECD: Congested – res/Minor	16,95%	20,4%

6 Conclusions

The work allows us to draw conclusions that can be placed on two distinct levels: the energy level and the methodological level.

As regards the energy level, it can be established that for the vehicles examined, i.e. city buses, parallel hydraulic hybridization allows conspicuous reductions in consumption, depending on the type of use of the vehicle: for congested city journeys, such as those of Italian cities, the reduction is around 24%; on mixed city routes the reduction is 16-18%. The study methodology followed in this work focuses on the conventional sizing of the parallel hybrid system followed by an optimal sizing.

The first step produced a parallel hydraulic solution capable of reducing consumption by about 20% in congested city routes; the second step allowed, on the same routes, a further reduction of 4-5 percentage points, which lead to a 32% increase in fuel economy. Regarding the indications provided by the optimal sizing, it can be said that it pushes towards greater dimensions of pump, but not for the accumulator, and highlights the role of the gear reducer, whose transmission ratio depends on the speed of use of the vehicle. The role of optimization is emphasized, which is not secondary in this study process, tending to avoid the rejection of the solution.

Finally, considering the problem from an economic perspective, it is emphasized that hydraulic hybridization is based on a mature technology, characterized by low initial costs and low maintenance costs. Furthermore, the low cost of disposal at the end of life of the components, which are mainly made of steel, should not be overlooked, while the disposal of electric vehicle batteries is, for now, expensive and not free from ecological-environmental implications.

Parallel hydraulic hybridization therefore constitutes an interesting solution for reducing consumption in off-highway machines, which should be reconsidered in the priorities of manufacturers.

References

1. J. Kargul et al., *Design and Demonstration of EPA's Integrated Drive Module for Commercial Series Hydraulic Hybrid Trucks and Buses*, SAE Int. J. Commer. Veh., **8**(2), 549-567 (2015)
2. P. Buchwald et al., *Improvement of Citybus Fuel Economy Using a Hydraulic Hybrid Propulsion System — A Theoretical and Experimental Study*, SAE Transactions, **790305** (1979)
3. Hydraulic Launch Assist the Eaton HLA® System, Eaton HLA1.ppt, 2008.
4. S. Hui, J. Ji-hai, W. Xin, *Torque control strategy for a parallel hydraulic hybrid vehicle*, J. Terramechanics, **46**, 259-265 (2009)
5. T. Liu et al., *A Study on Control Strategy of Regenerative Braking in the Hydraulic Hybrid Vehicle Based on ECE Regulations*, Math. Probl. Eng., **2013** (2013)
6. S. Hui, *Multi-objective optimization for hydraulic hybrid vehicle based on adaptive simulated annealing genetic algorithm*, Eng. Appl. Artif. Intell., **23**, 27-33 (2010)
7. Y. Chen et al., *Dynamic analysis of energy storage unit of the hydraulic hybrid vehicle* Int. J. Automot. Technol., **14**, 101-112 (2013)
8. Y. Yan, G. Liu, J. Chen, *Parameter design strategies of a parallel hydraulic hybrid bus*, IEEE VPPC, 1-6 (2008)
9. Y. Yan, G. Liu, J. Chen, *Integrated modeling and optimization of a parallel hydraulic hybrid bus*, Int. J. Automot. Technol. **11**, 97-104 (2010)

10. S. Zhou, P. Walker, N. Zhang, *Parametric design and regenerative braking control of a parallel hydraulic hybrid vehicle*, Mech. Mach. Theory, **146** (2020)
11. B. Wu et al., *Optimization of power management strategies for a hydraulic hybrid medium truck*, Proceedings of the 6th international symposium on advanced vehicle control (AVEC '02), **6** (2002)
12. Y. J. Kim, Z. Filipi, *Simulation study of a series hydraulic hybrid propulsion system for a light truck*, Int. J. Commer. Veh., **116**, 147-161 (2007)
13. P. Matheson, J. Stecki, *Development and Simulation of a Hydraulic-Hybrid Powertrain for use in Commercial Heavy Vehicles*, Int. J. Commer. Veh., **112**, 114-123 (2003)
14. Z. Filipi et al., *Combined optimisation of design and power management of the hydraulic hybrid propulsion system for the 6 × 6 medium truck*, Int. J. Heavy Veh. Syst., **11**, 372-402 (2004)
15. Gh. H Payeganeh , M. Esfahanian, S. Pakdel Bonab, *Modeling and Fuzzy Control Strategy Design for the Hydraulic Hybrid Refuse Truck*, ISE, **4**, 685-698 (2014)
16. B. Wu et al., *Optimal power management for a hydraulic hybrid delivery truck*, Veh. Syst. Dyn., **45**, 23-40 (2004)
17. Simcenter Amesim 2020.1. Siemens Industry Software NV.
18. <https://dieselnet.com/standards/cycles/index.php>