



UNIVERSITÀ
DEGLI STUDI
DI PADOVA

Sede Amministrativa: Università degli Studi di Padova

Sede Consorziata: Università degli Studi di Bergamo

Dipartimento di Ingegneria

SCUOLA DI DOTTORATO DI RICERCA IN: Ingegneria Industriale

INDIRIZZO: Ingegneria della Produzione Industriale

CICLO XXV

FUNCTIONAL-BASED APPROACHES FOR SUPPORTING PRODUCT DEVELOPMENT

Direttore della Scuola: Chiar.mo Prof. Paolo Colombo

Coordinatore d'indirizzo: Chiar.mo Prof. Enrico Savio

Supervisore: Chiar.ma Prof.ssa Caterina Rizzi

Dottorando: Tiziano Montecchi

(firma del dottorando)

Table of Contents

Abstract	4
Riassunto	9
Introduction to the research activity	13
Functional approaches in Design	17
2.1. Historical overview	17
2.2. Functional targets	18
Functional patent search for decision making	29
3.1. State of the Art and White Space Opportunities of a given product or technology	33
3.2. Technological Transfer of a given product or technology	39
3.3 Case study	42
3.4. Evaluation of performances	49
Functional approach for formulating problems according to TRIZ contradiction model	55
4.1. Problem typologies	56
4.2. An overview on TRIZ contradictions	59
4.3. From an inventive problem to its contradiction in four steps	64
4.4. Using functional knowledge to support contradictions extraction and formulation	68
4.5. Case study	74
KOM a conceptual patent search engine for supporting functional search ...	80
5.1. KOM a concept-based tool for searching patent	82
5.2 Case study	88
Conclusions	92
Bibliography	94

Abstract

The process of product development consists of a series of stages to transform an idea into a new product ready for the market. Starting from the earliest stages of identification of market opportunities, till the final stages of product manufacturing, information plays a crucial role. Every stage of product development is supported by many dedicated methods and tools. On the contrary, knowledge management strategies for supporting product development have not reached the same level of development. Often users rely on the text mining tools without a proper strategy, using indeed their own intuition and knowledge of field experts.

The **objective** of this thesis is to propose a systematic searching approach based on the functional decomposition of the product. In the first place, the development of this method consisted of the study and selection of the main methodologies of design, problem solving and design rationale (such as FBS, TRIZ, EMS model, and others), and later a reworking of them has been done in order to transform them into research targets. Each stage of product development process requires strategies, therefore different research targets. At present, strategies to support problem reformulation, problem solving, construction of the state of the art and technological transfer have been tested.

Since the effectiveness of a documentary search depends on the capability of text mining tools to obtain high recall, after testing several tools on the market, it was decided to develop and patent a special search engine that works with concepts exploiting libraries based design methods as knowledge bases.

The thesis is organized as follows:

In Chapter 2, we deal with defining the information to be searched. This information is described in the form of functions and they are identified through **research targets**, i.e. those key concepts that have to be found in documents with appropriate research strategies. These research targets are created using the main design methodologies properly selected. Once these targets are known, different research strategies have been defined according to the goal we want to achieve (decision making and problem solving).

Chapter 3. With the aim of supporting the activities of **decision making**, it has been developed a strategy to provide the proper knowledge to the designer in order to understand whether and how a specific product (or technology) can be innovated. For this purpose, the design methodologies have been used for inventing/creating the research targets to find all the possible alternative products. Subsequently, a patent search uses these targets to understand which of these systems are already present at the state of the art, because they are already patented in our field and which systems are not yet patented, representing an opportunity for development (white space opportunities). In addition, using a further functional search other technological areas are investigated to understand if those systems, not yet present in our field, have already been developed in other technological fields to reach our same goal. This information, properly organized, can be used as support for technological transfer.

Chapter 4. As a support to the **problem-solving** activities, we have been developed a strategy for problem formulation according to the model of TRIZ contradiction, in other terms as a conflict between two functional requirements. In particular, we propose a formulation of the problem based on a process of retrieving and

structuring the proper knowledge in order to facilitate the resolution of the problem itself.

Chapter 5. In order to test the effectiveness of these research strategies it was necessary to develop a new **search engine** that searches for concepts, rather than by keywords. In fact, the concept-based search can highly increase recall of the information retrieval process if compared with the more traditional research based on a combination of keywords selected by experts. It has been developed and patented a semantic search engine, called KOM, which integrates the basic text mining techniques such as tagging and parsing analysis. In particular, the search engine uses the patent literature as a source of information from which we can gain the knowledge.

The proposed research strategies have been applied to several industrial cases in the field of mechanical engineering, household appliances, biomedical and pharmaceutical industries. In the work of this thesis two explicative examples are presented about: decision making strategies applied to the technology of sterilization of contact lenses, and problem solving strategy applied to the case of the nutcracker.

The application using the industrial case studies have allowed to verify the effectiveness of the conceived strategies and tools, showing significant results, especially related to the improvement of recall of information retrieval. It is under definition an exhaustive evaluation (of these strategies) that involves the technical staff of the companies that have provided the industrial case studies. For what concerns the future developments, due to the development of KOM search engine in the last year of my PhD, it will be possible to conduct a validation of the proposed strategies with a more representative sample. In addition, KOM will reduce the time to develop and test new

research strategies for supporting other activities of product development.

Keywords: functional analysis, design methods, patent search, knowledge management, problem solving, TRIZ, technological transfer.

Riassunto

Il processo di sviluppo di un prodotto rappresenta l'insieme delle attività svolte ai fini di tradurre un'idea in un prodotto che possa essere commercializzato. Dalle primissime fasi di individuazione delle opportunità di mercato, fino a quelle finali di realizzazione del prodotto, l'informazione gioca un ruolo cruciale. Ogni fase dello sviluppo prodotto conta innumerevoli metodi e strumenti dedicati. Le strategie di gestione della conoscenza a supporto dello sviluppo prodotto invece non sono altrettanto sviluppate. Spesso l'utente si affida agli strumenti di text mining senza una vera e propria strategia, ma basandosi sul proprio intuito e conoscenza del settore.

L'**obiettivo** di questa tesi è proporre un metodo sistematico di ricerca basato sulla scomposizione funzionale del prodotto. La messa a punto di questo metodo è consistita in primis nello studio e selezione dei principali metodi di design, problem solving e design razionale (quali FBS, TRIZ, EMS model, ed altri), e successivamente in una loro rielaborazione al fine di trasformarli in target di ricerca. Ogni fase del processo di sviluppo prodotto necessita strategie e quindi differenti target di ricerca. Al momento, sono state testate strategie a supporto della formulazione del problema, del problem solving, della costruzione dello stato dell'arte del prodotto e del trasferimento tecnologico.

Poiché l'efficacia di una ricerca documentale dipende dalla capacità che gli strumenti di text mining hanno di ottenere elevate recall, dopo aver testato numerosi strumenti in commercio è stato deciso di sviluppare e brevettare un apposito motore di ricerca che lavora per concetti sfruttando come basi di conoscenza delle librerie basate sui metodi di design.

La tesi è così articolata:

Nel **Capitolo 2** ci si occupa di definire le informazioni da ricercare. Queste informazioni sono descritte sotto forma di funzioni e vengono individuate attraverso **target di ricerca**, ovvero quei concetti chiave da ricercare all'interno dei documenti con opportune strategie di ricerca. Questi target di ricerca sono creati utilizzando le principali metodologie di progettazione opportunamente selezionate. Una volta noti questi target sono state definite strategie di ricerca diverse secondo l'obiettivo da raggiungere (decision making e problem solving).

Capitolo 3. Con l'obiettivo di supportare l'attività di **decision making**, è stata messa a punto una strategia per fornire al progettista la conoscenza necessaria a capire se e come uno specifico prodotto (o tecnologia) possa essere innovato. A questo scopo, le metodologie di progettazione sono state utilizzate per inventare/creare i target di ricerca con cui trovare tutti i possibili prodotti alternativi. Successivamente, una ricerca brevettuale utilizza questi target per capire quali di questi sistemi siano presenti allo stato dell'arte perché già brevettati nel nostro settore e quali non siano ancora brevettati, rappresentando un'opportunità di sviluppo (white space opportunities). Inoltre, sempre utilizzando una strategia di ricerca funzionale vengono indagati altri settori per capire se quei sistemi che ancora non esistono nel nostro settore siano stati già sviluppati in altre aree tecnologiche per raggiungere il nostro stesso obiettivo. Queste informazioni, opportunamente organizzate, possono essere utilizzate a supporto dell'attività di trasferimento tecnologico.

Capitolo 4. Per supportare l'attività di **problem solving** è stata messa a punto una strategia per la formulazione del problema secondo il modello di contraddizione TRIZ, ovvero come

conflitto tra due requisiti funzionali. In particolare, si propone una formulazione del problema basata su un processo di reperimento e strutturazione della conoscenza che agevola la risoluzione del problema stesso.

Capitolo 5. Per poter testare l'efficacia di queste strategie di ricerca è stato necessario sviluppare un nuovo **motore di ricerca** che effettua ricerche per concetti, invece che per parole chiave (keyword). Infatti, la ricerca basata su concetti permette di incrementare notevolmente il recupero (recall) delle informazioni rispetto a ricerche più tradizionali basate sulla combinazione di parole chiave selezionate da esperti. E' stato così sviluppato e brevettato un motore di ricerca semantico, **denominato KOM**, che integra le basilari tecniche di text mining come l'analisi grammaticale e sintattica. In particolare, il motore di ricerca sfrutta la letteratura brevettuale come fonte d'informazione da cui reperire la conoscenza.

Le strategie di ricerca proposte sono state applicate a diversi casi industriali nel campo della meccanica, degli elettrodomestici, della biomedica e della farmaceutica. A titolo esplicativo nel lavoro di questa tesi si riportano, le strategie per il decision making applicate alla tecnologia di sterilizzazione delle lenti a contatto, e la strategia per il problem solving applicata al caso dello schiaccianoci.

La sperimentazione mediante i casi di studio ha permesso di verificare l'efficacia delle strategie e degli strumenti sviluppati ed ha portato a risultati significativi, soprattutto per quanto riguarda l'aumento della recall del processo di information retrieval. E' in fase attuativa una validazione esaustiva che coinvolge anche il personale tecnico delle aziende che hanno fornito i casi studio. Per quanto riguarda gli sviluppi futuri, grazie allo sviluppo dello strumento KOM

nell'ultimo anno di dottorato, sarà possibile condurre una validazione delle strategie proposte con un campione più rappresentativo. Inoltre, sarà possibile creare e testare in tempi molto più ristretti nuove strategie di ricerca a supporto di altre attività dello sviluppo prodotto.

Parole chiave: analisi funzionale, metodi di progettazione, ricerca brevettuale, gestione della conoscenza, problem solving, TRIZ, trasferimento tecnologico.

Chapter 1

Introduction to the research activity

In engineering, product development is the process consisting of a series of stages to transform an idea into a new product ready for the market. All the main phases of this design process (Pahl and Beitz 1977) can have gaps of knowledge, we can need information in the initial phase of planning and task clarification to find and select product ideas, clarify the task, or define the requirements list. We also need to acquire the proper knowledge in the conceptual phase to formulate the essential problems, establish functions, working principles and working structures as well as in the phase of embodiment design to develop the construction structure of the product and finally, also in detail design phase to prepare production and operating documents.

One of the techniques to gain the proper knowledge is the functional search. A functional search can involve many different aspects of a product, we can describe a function in terms of which is the goal of the product, or how it achieve this goal, or which transformation is performed by the product,

or which inputs are changed in which outputs, and many other ways can be used.

A function-oriented search can be performed on different information sources, such as scientific papers, encyclopaedias, textbooks, handbooks, patents, monographs, technical reports, etc. and even the web in general. Among all these information sources, the author focuses his attention on the patents, because patent database is a huge collection of technical knowledge, containing over 80 million of documents¹ and it represents a unique and exhaustive source of information (Lupu, Mayer et al. 2011). Moreover, patent database has also other useful features for Information Retrieval process, it has high accessibility, since it is free available on the web and it has a high level of format uniformity, this enables that electronic patent data can be searched individually or strategically together.

Working on function is a crucial point for extracting every kind of information from patent documents. Dozens of attempts are reported in literature about how to define an accurate set of verbs to identify Inventive Principles. Such verbs are used as keywords constituting queries during information retrieval works. Other function-oriented searches, based for example on SAO extraction, are numerous but in general they cannot offer good results without an accurate definition of all the keywords related to the given function. For these reasons, it is usually suggested that the best expert in the identified leading area should be found and that these activities should be supported using professional databases. Whatever activity is proposed, identifying and managing the right keywords to find patents

¹EPO Patent Information Conference 2012 (6-8 November 2012, Hamburg, Germany). <http://www.epo.org/news-issues/press/speeches/20121109.html>

dealing with a given function is a task requiring sensitivity and experience. Indeed searching for a function does not only mean finding synonyms (verbs with the analogous meaning that, substituted for the given one in the same context, do not change the right value of the proposition) but also involves exploring a variety of linguistic forms and relationships among words in order to throw up the related implicit knowledge function. In fact, inventions granted in patents contain functional aspects that inventors describe in very different ways. In fact, an inventor can describe its inventive solution as a system able to achieve a certain goal, or how it works, its functioning principles, its physical effects, its structure, the transformation it performs, how it solves a conflict between two requirements, etc. All these ways describe the function from different points of view, thus if we want to conduct an exhaustive functional search we need to know all of them.

Fortunately, in design science many functional approaches and methods have already been created to represent the functional aspect of a system. In this research activity, we have studied functional methodologies, approaches and tools coming from design in order to find the most comprehensive number of ways unconsciously used by inventors to write patents. Starting from this study, we propose a radically different approach to perform a function-oriented search. This new functional approach exploits the functional theories and instruments of design to create functional targets that are searched by well-known text mining techniques. This topic is discussed in detail in Chapter 2. This functional search is applied for finding desired information to support decision making (Chapter 3) and problem solving based on TRIZ contradiction model (Chapter 4). In Chapter 5, we propose KOM, a semantic patent search tool

developed by the author. KOM uses semantic parser and many knowledge bases for carrying out a conceptual patent search to improve the recall of the conceived functional search. Chapter 6 draws conclusions.

Chapter 2

Functional approaches in Design

This chapter introduces a selection of methods or approaches which are used in literature to describe the functional aspect of technical systems without any claim to completeness. In particular, we point out which functional targets can be derived from each of the presented approaches proposed and the main differences between them.

2.1. Historical overview

Since the '70s, product design has been focused on the function of a device rather than its mere structure. An historical overview of the definition of function can easily be found in literature. According to Rodenacker (1971), function is an input-output transformation while Pahl and Beitz (1977) describe it as a verb that does not necessarily express a transformation but also as conservation between input and output. These authors describe function as a black-box working in a specific way on a flow of information, energy or matter. In

the same period, Miles (1972) considers economic aspects linked to functional design and Collins (1976) creates a first function database.

FBS researchers provide different definitions about function, linking it to behaviour. According to Umeda et al. (1984), function is "a description of behaviour recognized by a human through abstraction in order to utilize it". Gero (1990) considers language use of the word "function", differentiating the concepts of function and behaviour: the first concept represents purposes of a device while the second one explains working conditions. Other authors, e.g. Vermaas and Dorst (2007) or those already mentioned above, e.g. Umeda et al. (1995) or Gero (2002) provide also other definitions.

They follow this approach agreeing on the definition of function as a heterogeneous set of requirements. Among them, there is the Useful Function introduced by Altshuller (1984) that represents the reason for which a device exists.

2.2. Functional targets

Different functional approaches give different definitions of function. At difference of traditional patent searches that look for information, the aim of our approach is to support the user in inventing all the ways to express a function, the functional targets, then we search for them inside information sources. In the following, it is shown as different functional approaches can generate different targets for the functional search.

Input and output.

For example, we take into account the electrolysis of water that is the decomposition of water into oxygen and hydrogen gas due to an electric current being passed through the water. If we describe the function according to the models of Rodenacker (1971) and Pahl (1977) a function is the transformation of inputs in outputs. In this case, "water" and "electric energy" are the inputs and "oxygen", "hydrogen" and "chemical energy" are the outputs, see Figure 1. Thus, instead of using only the verb "electrolyze" to describe the function of electrolysis, inventors can express it as the "transformation of water into oxygen and hydrogen" and "chemical energy" (output).

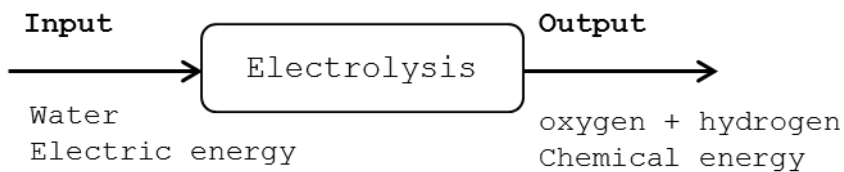

Figure 1. Conversion of energy, material and signals. Function of the electrolysis described on the basis of inputs and outputs.

Two elements and their interaction.

If we consider Miles's model (1972), the function can be described as two elements (one element that acts on another element) and the interaction they exchange, see Figure 2. Thus, electrolysis can be described as "electric current decomposes water".

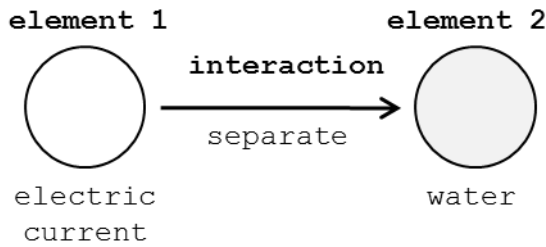

Figure 2. Function of electrolysis described as two elements and their interaction.

Tool-Object-Product.

The TOP model of Altshuller (1984) is a representation of a function based on three elements, see Figure 3. The Tool is defined as the only part of the system directly in contact with the Object. The Object is the element that is changed by the Tool into the Product that is the result we want to achieve every time we use the system. To make this transformation, the system provides an action onto the Object. According to this model, we have electric energy (tool), water (object) and oxygen and hydrogen (product). Thus, for example we can describe the function as “electric current produces oxygen and hydrogen”.

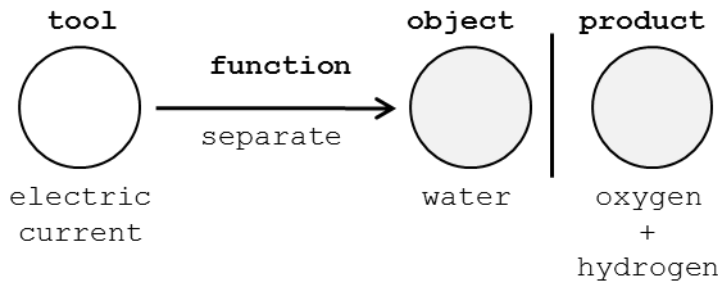

Figure 3. Function of electrolysis described by the Tool-Object-Product model.

Operative zone.

According to the model of function suggested by Altshuller (1984) we can describe a function specifying where the function is applied (space). For example if we consider the function "cracking" of a nutcracker, changing the zone of interaction we can invent different functional targets that can be used by inventors to describe this function, such as: "drilling", "fracturing", "compressing", etc.

Operative time.

The same of the space can be done for the time of a function considering how it changes in time (time). For example, if we consider the function of "moving a door", changing the time of interaction we can describe it as "slam the door" (short time), "move forward and backward" (repeatedly), "a jerkily movement" (with pause), etc.

Substance-Field.

Substance-Field model by Altshuller (1984) specifies the interaction between the tool (substance 1) and the object (substance 2) by a field describing what kind of physical interaction is exploited. Typologies of field are: mechanical, acoustic, thermal, chemical, electric, magnetic, electromagnetic and biological, see Figure 4. This model suggests that inventors can also describe the field of interaction, for example, if we consider a nutcracker we can search for a mechanical cracking, acoustic cracking, thermal cracking, etc.

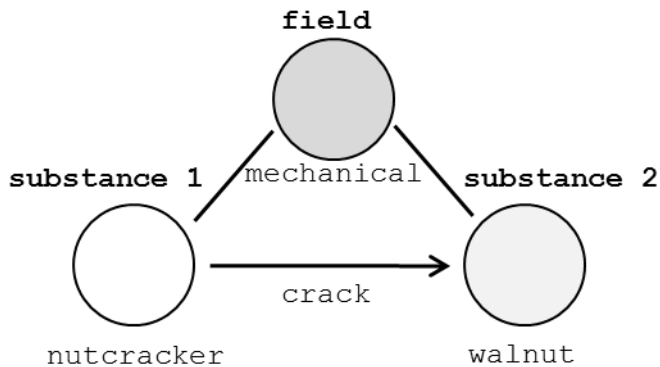

Figure 4. Function of a nutcracker described by the Substance-Field model.

76 Inventive Standard Solutions.

Inventive Standard Solutions is a tool deriving from TRIZ (Altshuller 1984; Petrov 2003). Given a problem, the solutions are limited in number. These solutions are 76, represented by functional models and classified according to the typology of problem (insufficient function, harmful function, excessive function and problem of measurement). Instead of searching solutions randomly this tool suggests a list of conceptual solutions for each type of problem. For example, if a nutcracker is not able to crack hard walnuts (insufficient function), this tool suggests to intervene on the walnut modifying physical/structural characteristics, introducing new elements inside and outside it, modifying the environment, or the way through which the shell receives the action of cracking. The same modifications can be done on the levers of nutcracker but also more radical modifications, such as a substitution of the levers with alternative systems, or think to fragment or dynamize them, or imagine to modify the interaction of cracking (if we have a mechanical cracking, try to change or integrate

with thermal, chemical, electrical or electromagnetic cracking), or modify the way the cracking action is provided over time (continuous, pulsating or resonant), during possible pauses and in its intensity. For the example of nutcracker, Figure 5 shows the model of the problem with cracking function considered as insufficient and one of the related solution model described in functional terms. In particular, the solution model is the Inventive Standard Solution 2-1-2.

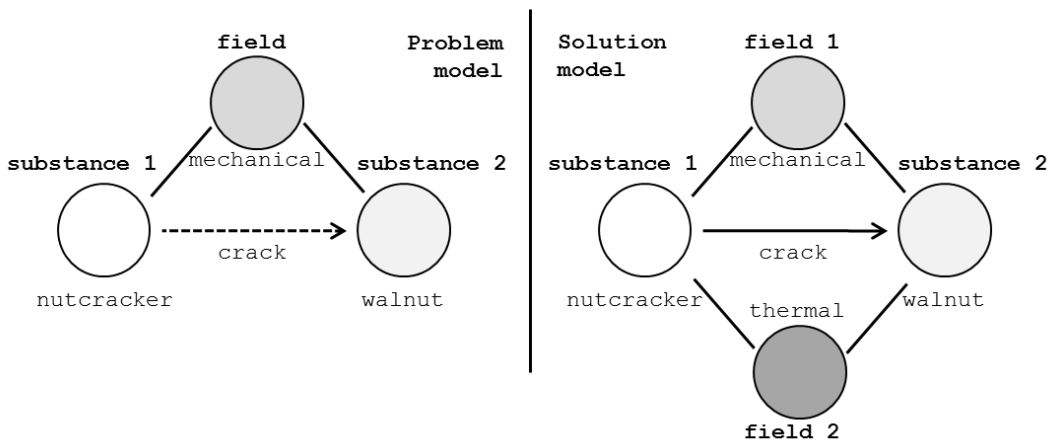

Figure 5. Problem of nutcracker and one of the related solutions described in functional terms by the Inventive Standard Solutions. In particular Standard Solution 2-1-2 is represented.

TRIZ Contradiction.

Contradiction is an instrument of the Theory of Inventive Problem Solving (TRIZ) (Altshuller 1984). The starting point for its application is typically a technical problem. For instance, a device that does not work as we want or it does not satisfy all its requirements. Several ways exist to solve this problem: avoiding it, treating it with a compromise, etc. TRIZ offers a no compromise solution. According to Khomenko's OTSM

contradiction model (Cavallucci and Khomenko 2007) if a device must satisfy two requirements respectively called Evaluation Parameter 1 (EP1) and Evaluation Parameter 2 (EP2), the overcoming of the contradiction leads to this goal (see figure 2). For this reason, TRIZ suggests us to act on a Control Parameter (CP) belonging to the device and which can be modified (Figure 6). The theory provides several tools and tips in order to help designer in this task. Contradiction is a functional representation of the problem in terms of two conflicting requirements.

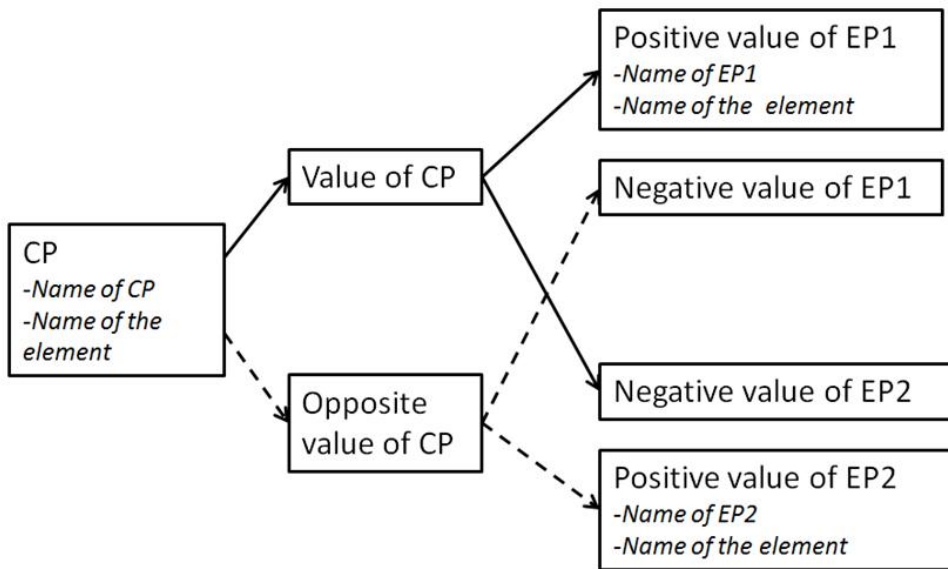

Figure 6. Functional description of the problem using OTSM scheme of contradiction.

FBS.

Gero proposes the FBS model (Gero 1990) in order to describe the design process. Variables and design choices are grouped by three classes of variables describing different aspects of a design artefact:

- Function (F): "is the motivation for Technical System existence", that is, what it is for (Gero and Rosenman 1990).
- Behaviour (B): "is defined as sequential changes of objects state governed by the Laws of Nature; B is the link between Function and Structure. Different behaviours can produce the same Function, as well as different Structures can be characterized by the same Behaviour", that is, what it does (Gero and Rosenman 1990).
- Structure (S): describes the components of the object and their relationships, that is, what it is.

At difference of the other approaches, this model describes the functional aspect of a system at three different levels (Table 1), where the level of the function (F) is the most abstracted one: the purpose of the system (its requirements). For the example of nutcracker its purpose is "opening a nut" while "cracking" is a way (B) to open a nut. An inventor can describe a nutcracker just mention its purpose "opening a nut".

Table 1. Function of a nutcracker described by FBS model.

FBS model	Example
Function	Open
Behaviour	Crack
Structure	Nutcracker

Moreover, function (F) and behaviour (B) can be decomposed relatively in sub-functions (Umeda and Tomiyama 1995; Chandrasekaran 2005) and sub-behaviours (Cao and Tan 2007). For example, the function "playing a cd" we can describe it through two sub-functions: "rotating cd" and "reading cd".

FBPhS.

This model is derived from the original definitions of Gero and it has been developed by Russo et al. (2011) separating the concept of Physical Effect (Ph) from Behaviour (B) (Table 2). To better understand this level, the concept related to the physical phenomenon must first be introduced. A physical phenomenon is the cause of a state transition from state one to state two. Thus a behaviour can be described by its initial state and a set of physical phenomena (Umeda and Tomiyama 1995). The physical effects (Ph) are the laws of nature governing change, so a physical phenomenon is associated with a given PE. Activation of a (Ph) is necessary to create physical phenomena and changes of state (Chakrabarti, Sarkar et al. 2005).

In the example of nutcracker, this model helps to think to the Physical Effect (Ph) used for cracking a nut (B) in order to open it (F), e.g. compression. An inventor can use only terms related to the Physical Effect (Ph) of "compression" to describe a nutcracker.

Table 2. Function of a nutcracker described by FBPhS model.

FBPhS model	Example
Function	Open
Behaviour	Crack
Physical Effect	Compress
Structure	Nutcracker

ENV model.

The ENV (Element, Name of the property, Value of the property) model is a universal model proposed in OTSM-TRIZ (Cavallucci and Khomenko 2007) for describing a system or a problem. The

structure has been derived from a well-known model in Artificial Intelligence Object-Attribute-Value. The Element (E) is any kind of item in the system under analysis (both material and immaterial). The Name of the property (N) indicates any characteristic, feature, or variable which can be associated to the element (E). Whatever the property is, it must have at least two possible values (V); that is, the element (E) can assume at least two possible states distinguished by different values V1 and V2 of the property (N), see Table 3.

For example, the function of "heating a quantity of water" can be described also as the parameter (N) temperature of the element (E) water changes from the value (V1) 25°C to the value (V2) 100°C.

Table 3. Function of "heating a quantity of water" described by the ENV model.

Element (E)	Parameter (N)	Value 1 (V1)	Value 2 (V2)
water	Temperature	25°C	100°C

Databases of functional primitives.

Primitives are a small set of verbs that represent functions used as functional basis to describe more complex functions in a standardized way (Collins, Hagan et al. 1976; Modarres and Cheon 1999). Primitive functions can also be organized in classes according to the level of generality, from the most abstract verbs to most specific (Hirtz, Stone et al. 2002), see Figure 7.

<i>Class (Primary)</i>	<i>Secondary</i>	<i>Tertiary</i>	<i>Correspondents</i>
Branch	Separate		Isolate, sever, disjoin
		Divide	Detach, <i>isolate</i> , release, sort, split, disconnect, subtract
		Extract	Refine, filter, purify, percolate, strain, <i>clear</i>
		Remove	Cut, drill, lathe, polish, sand
	Distribute		Diffuse, dispel, disperse, dissipate, diverge, scatter

Figure 7. Functional basis developed by US National Institute of Standards and Technology (NIST).

Chapter 3

Functional patent search for decision making

Decision making is an activity that affects all the phases of product development. This chapter presents how a functional approach can support decisions in the phase of concept development. Decision of which new product we have to develop is often supported by two more focused activities: concept generation and concept selection (Krishnan and Ulrich 2001). In particular, in order to understand if and how a system (product or technology) can be innovated, we propose a functional search on patent database. Starting from the system we want to invent or innovate, the functional search identifies (1) all the alternative systems already developed (State of the Art) and (2) all those alternatives that are still available (not yet developed) in our technological field (White Space Opportunities). Moreover, functional search suggests (3) a list of alternative systems that belong to other fields that can be used for Technological Transfer.

Carrying out these three typologies of search means to identify the different ways of achieving the same goal. We call these ways: alternative systems. "Alternative systems" means all variants of a given technical system that are able to achieve the same goal. Every alternative system changes at least one element of the FB-Ph-S triple model, but the most radical alternatives deal just with modification of function and/or behaviour. Among all the alternative systems we decide to focus our attention on those that use different physical effects (Ph) to perform a behaviour (B) in order to achieve the main goal (F).

Searching for those alternative systems that differ in terms of physical effects (Ph), we can:

- Construct the State of the Art (SoA) of a product/technology and identify White Space Opportunities (WSO), see Sub-chapter 3.1.
- Perform Technological Transfer (TT) of a product/technology, see Sub-chapter 3.2.

Physical effects (Ph) are the key points of these activities, in fact the functional approach we propose is based on searching if a physical effect (Ph) is used or not to achieve a certain function (F) in different technological fields. In particular, this functional search is conducted on patent database and it is inspired to the SAO model (Subject-Action-Object) that was developed on patents by the TRIZ community (Altshuller 1984) and it has been deeply revised according to FBPhS model. The query we propose is composed of three typologies of research target:

- **Action:** this element expresses the action (A) provided by the system to achieve the goal (F). Action (A) comprises both research targets (F) and (B) coming from FBPhS model.

- **Physical Effect:** this element describes which (Ph) is used to activate action (A). It is constituted of (Ph) research targets and they are contained inside a pre-built library. This library had been conceived by merging different commercial Knowledge DBs of physical, chemical and geometric effects. It is a static list of nouns, verbs, adverbs and adjectives characterizing each (Ph), and classified according to one of the following general interactions: mechanical, acoustical, thermal, chemical, electrical, electromagnetic and biological. Each area is then further classified in physical effects (Ph) and completed with related keywords. For example, the "mechanical/compression" will contain keywords like pressure, compression, to press, to compress, to push, compressible, together with technologies (such as press machine, pressure roller, etc.) and other technical parameters (such as compressive coefficient, maximum tensile stress) or units of measure (Pa, bar, atm, psi, etc.).
- **Object:** this element expresses the object (O) that receives action (A). Also this element is turned into research targets.

Once, these three typologies of targets are created then they are searched inside documents using text mining techniques. They could be simply combined by means of AND Boolean operators, but this combination was demonstrated not to be enough effective for obtaining precise results. According to FBPhS, these three elements have to be linked in a unique proposition to be searched. In practice, following the FBPhS model our query can be compiled according to the Template 1:

«Which Physical Effect (Ph)» is used by the system «to perform an action (A) on the object (O)» in order to achieve the main goal (F)

Template 1. Query based on FBPhS used by the functional search to construct the SoA and identify WSOs.

Different tools can be used for searching this precise sentence in a text. At present, syntactic tools, such as proximity operators (for imposing distance between terms) are the most readily available, they can achieve good precision compared with the use of AND operator, but definitely they have recall limitations. In fact they work properly when linked concepts are expressed by terms close each other in the text, but they inevitably fail when concepts are distant or even belonging to different phrases.

More advanced text mining techniques are those based on semantic searches. Among all the tools for meaning recognition we mention: tagger-of-the-speech, syntactic parser, semantic role labelling based on electronic resources containing semantic frames, such as FrameNet (Ruppenhofer, Ellsworth et al. 2010) or PropBank (Kingsbury and Palmer 2003) and more in general NLP techniques for Latent Semantic Analysis. These tools can support in understanding the semantic meaning of a sentence, recognizing the role of each term and relations between terms. For example, if we take into account the phrase "Yesterday, Kristina hit Scott with a baseball", these tools can recognize that "yesterday" is a temporal adjunct, "Kristina" the subject, "hit" the verb, "Scott" the object, etc. They are able also to understand that phrases having different linguistic patterns have the same meaning, such as "Scott was hit by Kristina

yesterday with a baseball”, “With a baseball, Kristina hit Scott yesterday”, etc. In other words, potentially, they can recognize if the meaning of our query matches a patent text independently on how the concept is expressed inside the text, thus the precision of results is highly improved.

3.1. State of the Art and White Space Opportunities of a given product or technology

To build the SoA and identify the WSOs, we must find all the patents in our technological field describing alternative systems that perform the same function using different physical effects (Ph). Given the pre-established effects library:

- For each effect we create a list of queries according to Template 1.
- We launch these queries inside patents of our technological field (using patent classification).
- If at least one patent matches the query of Template 1 this means the direction described by that triplet F-B-Ph is already present at the SoA of our field, while in case any patents do not match the query a WSO is identified.

In practice, we propose to classify all patents of our technological field according to the different physical effects (Ph) used to perform a function (F), see Figure 8. To do that, we use each effect (Ph) contained in our pre-built library. If a physical effect (Ph) is described in one or more patents to achieve the desired goal (F), this system is already at the SoA, while others effect (Ph) not claimed in patents are the WSOs. WSOs are those physical effects (Ph) not yet exploited by any

competitors of our field, therefore they are possible directions for the development of our product/technology.

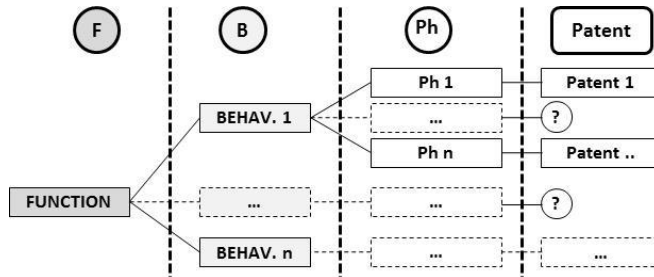

Figure 8. Tree-diagram of directions described by a physical effect (Ph) to perform a behaviour (B) for achieving a goal (F). Directions already exploited/patented and WSOs are mapped.

A software prototype, called Knowledge Organizing Module (KOM) (Russo and Montecchi 2011), has been implemented for aiding Information Retrieval phase. KOM contains suitable knowledge bases for supporting users to build and manage the functional targets, then it automatically expands such targets and finally it searches for documents using the query built according to the Template 1. This patent search is based on an algorithm to balance recall and precision of retrieval process. The algorithm is a sequence of steps, where some of them aim to improve recall for overcoming linguistic problems of patent searches, while others to increase precision for obtaining relevant patents.

In particular, KOM is invented to find all the ways to achieve a certain function (F) and in doing that it has to find at least one representative patent for each (Ph) that is already used at the SoA. Thus, the algorithm is conceived to find not all patents for each Ph (recall=1), but for retrieving a small set of really pertinent patents, in other words this algorithm gives priority to precision accepting low recall (see Chapter 5).

However, a further suggestion for filtering irrelevant results is to limit searches within our technological field, instead of seeking the entire database. In other words we have to circumscribe our functional search inside the pool of patents to which we are interested in. To do that, we use Patent Classification such as International Patent Classification (IPC), European Classification (ECLA), the new Cooperative Patent Classification (CPC), Unites States Patent Classification (USPC) (Montecchi T., Russo D. et al. 2013). Each full-digit patent class defines a specific technological field, so patent classes can be used as filter to narrow our functional searches. These filters allow to achieve good results in terms of precision (Russo and Montecchi 2011).

Results, we obtain by this functional search are:

- Directions of development (Ph) already developed at the SoA, because already patented in our field.
- Directions (Ph) not yet present at the SoA, they are called WSOs because they are potential directions of development not yet patented in our field.

In particular, results are visualized in form of a hierarchical tree-diagram based on the FBPhS model. Figures 9 and 10 show two examples of the SoA diagram related to a nutcracker and a water purifier respectively.

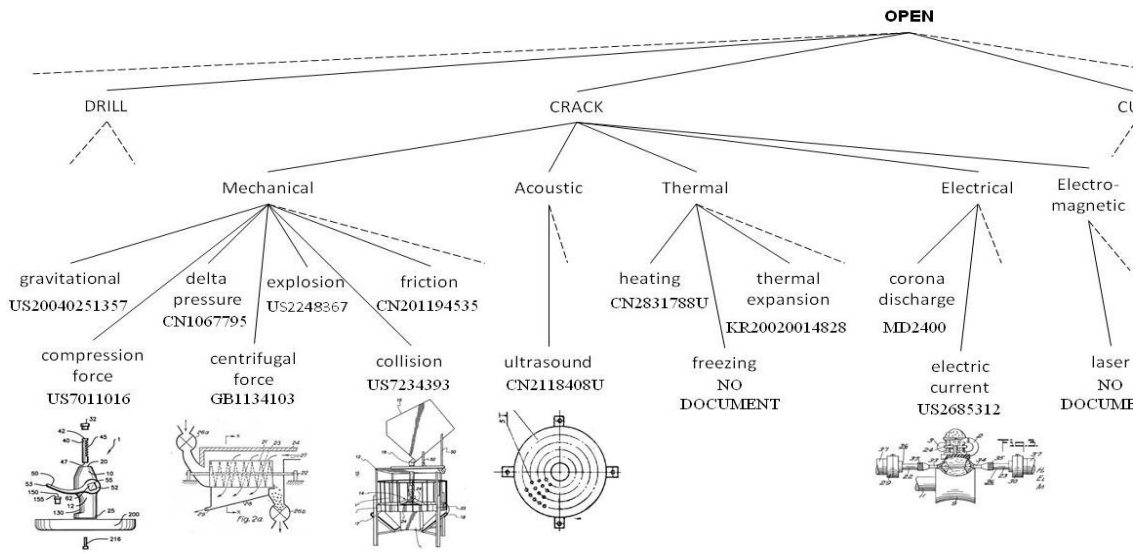

Figure 9. A partial representation of the SoA diagram of a nutcracker. Alternative systems of a traditional nutcracker are mapped, classified according to different effects (Ph).

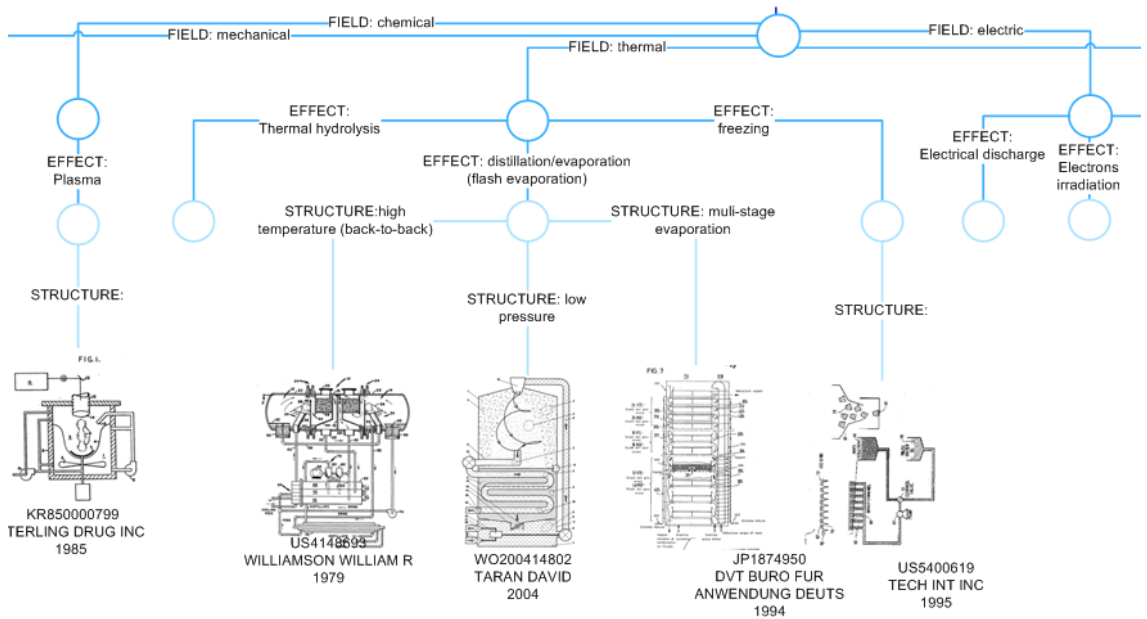

Figure 10. A partial representation of the SoA diagram of a water purifier. Alternative systems of a water purifier are mapped, classified according to different effects (Ph).

This very concise graphical representation allows an easy interpretation of results, offering a rapid overview of the SoA and WSOs organized according to (F), (B), (Ph) and (S) levels. On the diagram, only one patent for each branch is visualized. This patent is selected taking into account several criteria, such as assignee (especially competitors), inventor, data filing, grant or application, backward and forward citations, etc.

Moreover, patents obtained at the bottom of every single branch of the diagram can be manually classified according to the structures used to activate the physical effects (Ph), see Figure 11.

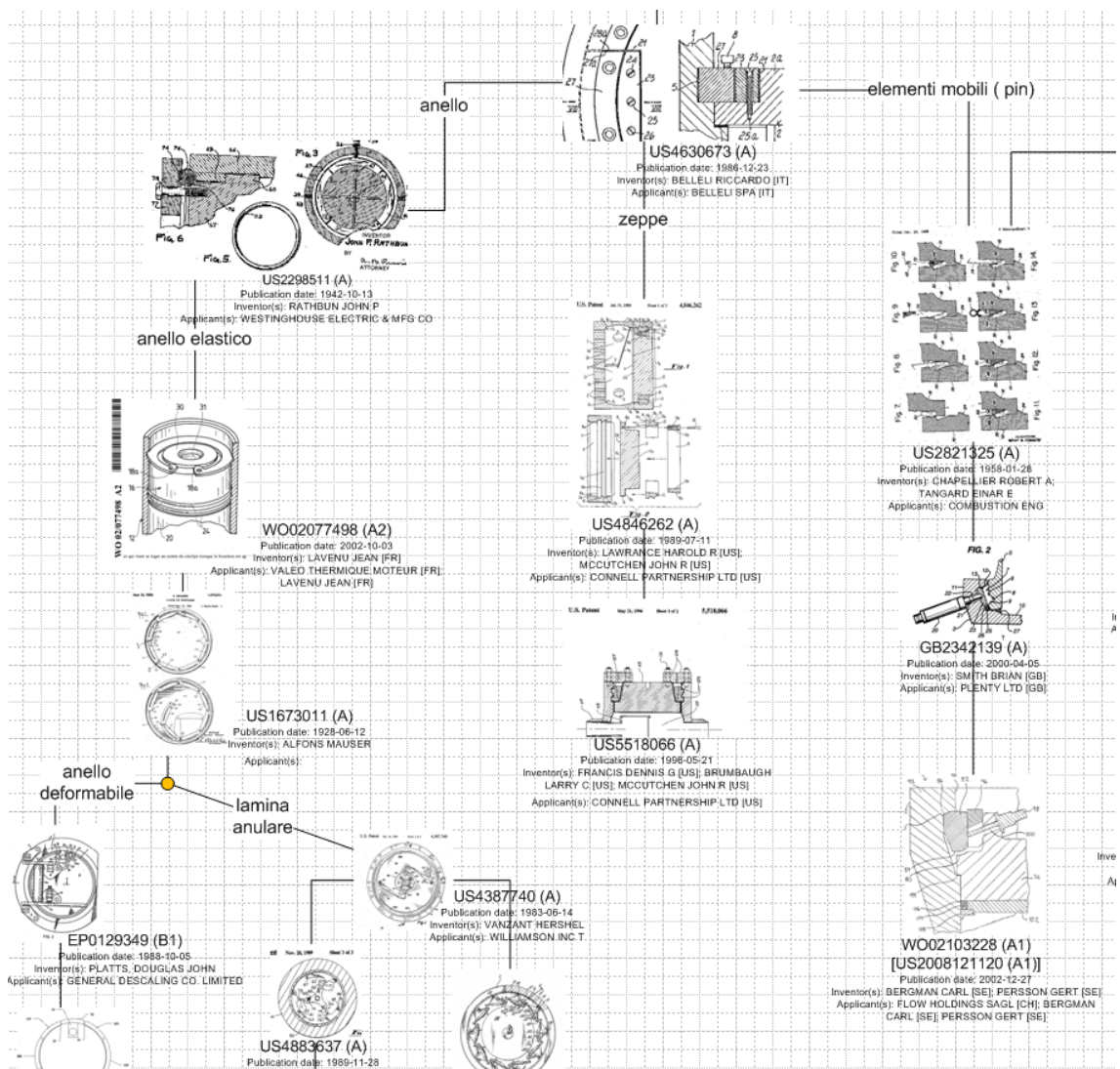

Figure 11. A piece of the tree diagram for the SoA of opening closure systems. Systems classified according to different structures (S) for opening closures.

3.2. Technological Transfer of a given product or technology

This functional search supports the Technological Transfer searching if someone has already patented in other technical fields a system to achieve our same goal(F) using a physical effect (Ph) which is not yet patented in our field (WSO). If someone has already patented a WSO in another field, this is a new direction to innovate our product. In fact, it means that a new physical effect (Ph), not yet developed in our domain, is already exploited in another to achieve our same function (F).

For searching in other fields the query shown in Template 1 has to be slightly modified. The author proposes to readapt the target of object (O) of the query for the new purpose by a systematic abstraction process.

Object abstraction: the object (O) changes from one field to another, e.g., sterilization of contact lenses, medical devices and foodstuffs. For this reason, it is systematically abstracted according to semantic relations contained in knowledge base, such as WordNet 3.0 dictionary (Fellbaum 2010). In particular, one relation is very useful to create targets for the abstracted object (Oab):

Hypernymy: Y is a hypernym of X if every X is a (kind of) Y (e.g. "lens" is a hypernym of "contact lens").

According to this relation, different levels of abstraction are generated, e.g. "contact lens, contact, ..." → "lens, lens, lens system, ..." → ... → "device, ..." → "object, ..." → ... These new targets are used to readapt the query of Template 1 for searching in different fields. The new query is built according to Template 2.

«Which Physical Effect (Ph)» is used by the system «to perform an action (A) on the abstracted object (O_{ab})» in order to achieve the main goal (F)

Template 2. Query based on FBPhS used by the functional search to perform technological transfer.

Moreover, when we want to investigate other fields, the Patent Classification filter that circumscribes our technological area has to be changed. If possible, we progressively widen the investigation area from the most specific (our field) to the most abstracted one. This process is based on the hierarchical structure of Patent Classification. From the starting class representing our field we move to the upper level of the hierarchy, the "father" class (e.g. for IPC from class A47J43/26 to class A47J43), then we can further extend our research areas using all the levels of hierarchy (e.g. for IPC A47J43, A47J, A47, A), till the entire DB (maximum extension) that it means to eliminate the Patent Classification filter. The hierarchy of Patent Classifications is not always built according to abstraction criteria, in these cases, we move from our field directly to the entire DB. For the reason that a "father" class contains also the "son" class, when we search in a father class we have to exclude the son class, otherwise we search again inside it, e.g. (IPC filter: (A47J43) not (A47J43/26))

In order to gain a 360° overview about which WSOs have been already developed in other fields, KOM runs a sequence of steps:

- For each WSO identified by the triplet (F)-(B)-(Ph), KOM algorithm launches a list of queries to balance recall and precision of results according to the new Template 2.

Differently from the SoA, the algorithm searches in external fields defined by new patent classes.

- For each external field KOM launches the query as many times as the number of levels of the abstracted object (O_{ab}).
- If a query matches against one patent, it means that someone has already patented a system to achieve our goal (in a way not present at the SoA of our system) and this new way is defined by the triplet (F)-(B)-(Ph).
- For knowing all potential WSOs, KOM repeats previous three steps for each WSO found in our field.

If, at least one query matches one patent, we have found a potential system for developing our product by TT. The outcome of the approach is visualized in form of a concise map, called technological transfer map (Fig. 6), indicating the SoA of our product and the WSOs. When a WSO is filled with a patent, this is indicative of technology transfer possibilities.

In order to have this process fully controlled by user, KOM software is provided by two cursors that allow us to investigate different fields and contemporaneously search using object at different levels of abstraction. In particular, one cursor allows us to manage the investigation areas by changing the patent class filter, the other permits to control the object abstraction. In this way, user can easily interact with the searching process, every time user changes one cursor, KOM launches new queries to search new patents. As the outcomes of his/her choice, new systems and their relative fields identified are immediately visualized on the technological transfer map.

Systems found by this approach are breakthrough solutions that bring to radical innovations, in fact this approach is created to find new physical effects (Ph) to achieve function (F) and

further suggesting which physical effects (Ph) are already patented in other domains. Once a new system is identified in external fields, such fields could be suitable for transferring knowledge in our domain to develop our system.

3.3 Case study

In this case study, we take into account the technology of contact lens sterilization and we present how the functional approach is used to:

- Construct the SoA and identify WSO of contact lens sterilization technology.
- Perform TT of contact lens sterilization technology.

State of the Art construction: contact lens sterilization.

We start in creating the functional target for the research using the design methodologies presented in Chapter 2. In particular, using the FBPhS model we identify "removing bacteria" as the goal (F) of contact lens sterilization (Figure 12), while "sterilizing contact lens" is the one of the behaviour (B) to remove bacteria (F). The other research targets (not shown in figure) are generated using the following functional approaches: 76 Inventive Standard Solutions, operative zone and time. These functional targets are partially represented in a tree-diagram (Figure 12).

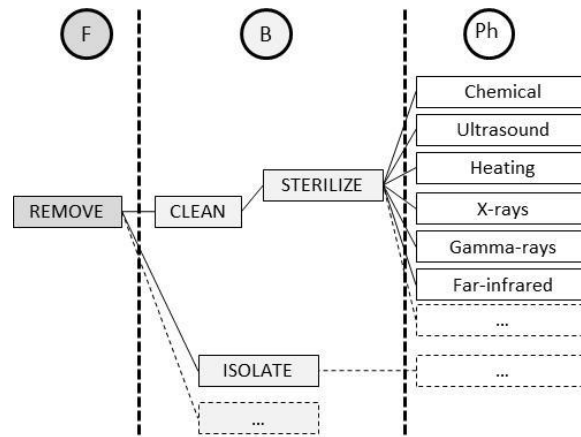

Figure 12. Functional targets organized according to a tree-diagram based on triplets: (F)-(B)-(Ph). Partial representation of the directions to “remove bacteria” (F).

Then KOM expands each target of the tree-diagram by knowledge bases and Information Retrieval techniques (see Chapter 5), e.g. the “sterilize” target becomes “steriliz-e, -es, -ing, -ed, sterilization, sterile, sterilant, sterilis-e, ..., disinfect, ..., antisepticiz-e, ..., antiseptic, aseptic, etc.” Finally, each target direction to “remove bacteria” is turned in queries for the patent search and launched in the field of contact lens sterilization defined by the IPC class: A61L12 - “Methods or apparatus for disinfecting or sterilising contact lenses; Accessories therefore” (in this application we have used the International Patent Classification as the filter).

An example of the final query generated by KOM algorithm is reported in Template 3. The query refers to the triplet: (F) “remove - (B) “sterilize” - (Ph) “ultrasound”, for searching systems to sterilize contact lenses by ultrasound. In this case, that query has matched at least one patent (e.g. EP0031152, Figure 13), so the system for contact lens sterilization by ultrasound is already used at the SoA. Then for obtaining a

complete SoA tree-diagram (Figure 13) each direction “to sterilize contact lenses” contained inside the target tree-diagram is turned into queries and launched. With this approach we have obtained different ways in form of (F)-(B)-(Ph) triplets to “remove bacteria” (F) from lenses.

Is the «physical effect (ultrasound)» used by a system «to perform the action (sterilize, disinfect, antisepticise, clean, ...) on the object (contact lens, contact)» in order to achieve the main goal expressed by the function (remove bacteria)?

Template 3. Example of query based on FBPhS that gives at least one result: ultrasound is a (Ph) already used at the SoA.

White Space Opportunities identification: contact lens sterilization.

In case of query has not matched any patents (inside the patent class A61L12), this direction is a WSO. An example of query that does not match any patent is given in Template 4.

Is the «physical effect (x-ray)» used by a system «to perform the action (sterilize, disinfect, antisepticise, clean, ...) on the object (contact lens, contact)» in order to achieve the main goal expressed by the function (remove bacteria)?

Template 4. Example of query based on FBPhS that does not give any result: x-ray is a WSO because it is a (Ph) not yet used/patented at the SoA.

Both directions already developed and WSOs in the field of contact lens sterilization are represented by the tree-diagram, Figure 13.

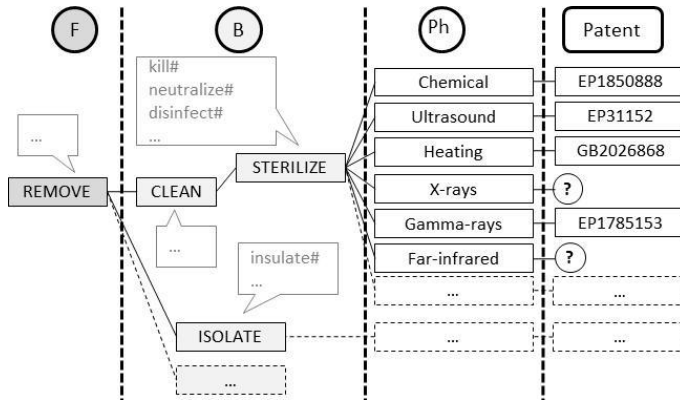

Figure 13. Tree-diagram of contact lens sterilization showing directions at the SoA (with patents) and possible WSOs (?) (free of patents).

Technological Transfer: contact lens sterilization.

External research areas are defined starting from the patent class A61L12 (defining contact lens sterilization field) and performing the generalization based on the hierarchy of IPC. For external investigation we choose the following three patent classes:

- A61L: "Methods or apparatus for sterilising materials or objects in general; ...";
- A61: "Medical or veterinary science; hygiene";
- No class (entire DB).

For searching inside A61L, A61 and the entire DB, the query shown in Template 3 has to be modified taking into account the abstracted object (Oab).

Object abstraction. For "contact lens" the abstraction obtained by semantic relations (suggested in WordNet) is shown

in the following (ascending order, from the most specific to the most abstract level):

- contact lens, contact, ...
- lens, lens, lens system, ...
- optical device, ...
- device, ...
- instrumentality, instrumentation, ...
- object, ...

Now, for every defined external area, KOM searches each WSO identified launching a query for the abovementioned levels of abstracted object. In other words, KOM does not search for ultrasound sterilization, because this direction is already present at the SoA, while it searches for x-ray sterilization that is not yet used in our field. In this way the number of launched query is reduced to only those physical effects (Ph) that are WSOs. The technology transfer map we obtain is shown in Figure 14.

As the outcomes of the process show, the proposed functional search based on FBPh targets is very effective to search both in our field and in external fields. In fact, patentees can describe the sterilization technology without using precise keywords such as "sterilize" or its synonyms, but they can use even terms such as "disinfect", "wash", "sanitize", "clean", etc. which are very general. The same for terms expressing the object (O) e.g. "... an X-ray irradiator capable of sterilizing an article such as a medical instrument ...".

Using the proposed approach for the functional search we have found 5 more physical effects (Ph) not yet present at the SoA that can be used to sterilize (see Figure 14).

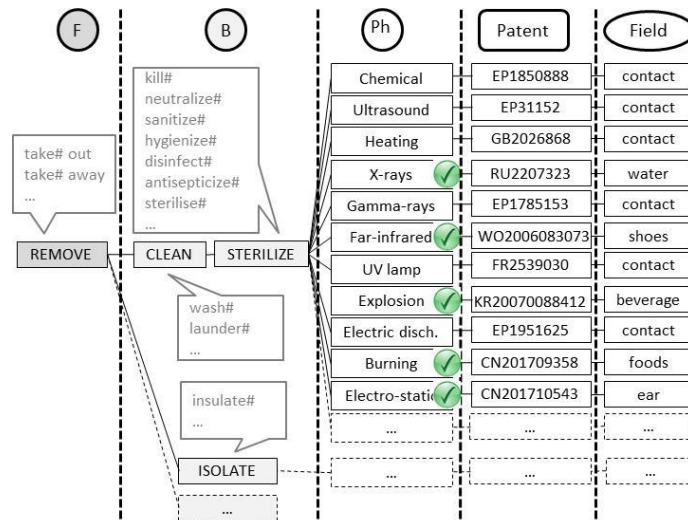

Figure 14. TT map: SoA and WSOs (ticked) found in different technical fields.

All these effects are already known in different areas and they could be transferred in our field to sterilize contact lenses. An analogy between starting area and “sterilization of medical instruments” can be generated by a domain expert, while analogies with the “sterilization of foods” or “beverages dispensing devices” are not obvious even for an expert, indeed links with the “sterilization of shoes” or “ear cleaning” are possible only if the expert already knows those solutions or he/she finds them randomly. Instead, the proposed method guides even a non-expert to investigate all different areas in a systematic and easy way just moving two cursors to try all possible combinations between different fields and different levels of object abstraction. In Table 4, one representative patent is reported for each query, actually for every field a list of patents could be retrieved.

Table 4. Representative patents matching the query of WSOs in different technical fields

IPC filter	Technical field	Physical Effect (Ph)	Patent number	Matched text
A61L	Medical devices sterilization	x-ray	JP2009058519	"... To provide an <u>X-ray</u> irradiator capable of <u>sterilizing</u> an article such as a medical instrument more completely at higher speed than a conventional method..."
No class	Water treatment	x-ray	RU2207323	"... Method consists in that liquid to be <u>disinfected</u> is directed to accumulating vessel where it is subjected to X-radiation produced by means of <u>X-ray</u> unit with directed radiation output. ..."
A61L	Shoes sterilization	far-infrared	WO2006083073	"The present invention relates to a <u>far infrared sterilizer</u> for shoes including: ..."
A61L	Foods or foodstuffs preservation	burning	CN201709358	"... the <u>burning</u> principle of the non-toxic fuel is utilized to remove the oxygen in the sanitary chamber, so that an oxygen-free or nearly oxygen-free negative-pressure environment can be kept in the sanitary chamber, consequently, substances stored in the sanitary chamber, such as food and tableware, can be kept fresh and clean ..."
A61L	Dispensing beverages on draught	explosion	KR20070088412	"A <u>sterilizing</u> and <u>washing</u> system is provided to conveniently and rapidly clean inside of a pipe by washing water having a sterilization power with energy generated by <u>exploding</u> compressed air. ..."
A61	Treatment of the ear	Electro-static	CN201710543	"The utility model discloses an <u>electrostatic ear cleaner</u> , which is characterized by comprising an ear <u>cleaning</u> portion and a friction portion ..."

Further, moving cursors we can find more than one field for each physical effect (Ph), for example the X-ray effect is

claimed in patents belonging to the medical field but also to the disinfection of sewage water (Table 4).

In conclusion, once we have found a patent with a new physical effect, we can gain information about:

- how long this technology is used in that specific domain to assess its maturity level;
- which problems are related to this technology (patent descriptions contain solved problems and often also a detailed explanation of drawbacks of the state of the art);
- which main actors play in this field: companies that most use this invention or groups (such as academy, R&D departments, etc.) that mainly research in this area;
- which are the other patent classes correlated to, for finding also other fields where the invention is exploited;
- which are the cited and citing patents to have a more comprehensive overview of the technology.

Thus, identification of these patents is the starting point to assess the technology they claimed and collect useful information to understand if it is possible to transfer this knowledge in our field and who are the main experts.

3.4. Evaluation of performances

In this chapter, the author presents an evaluation of the effectiveness of KOM patent search according to recall and precision. In particular, this evaluation takes into account the search of the sterilization technologies patented in the field of contact lenses. The aim of this patent search was to identify the physical effects used to sterilize in the field of contact lenses by retrieving at least one patent for each Ph.

Evaluation.

For the purpose of the evaluation we have manually built a pool of patents related to sterilization of contact lenses then. This pool has been created considering the IPC patent class (A61L12) related to patents for contact lenses sterilization (around 1330 patent families²). This collection of patents was manually cleaned up and the final pool has contained 1205 patent families related to the sterilization of contact lenses with English text (also abstracts with automatic translations were included). Then each of the 1205 families has been manually classified according to the physical effects (Ph) used. According to such a classification, physical effects (Ph) used to "remove bacteria" (F) are 19, as shown in Table 5. The sum of families of all physical effects (Ph) is higher than 1205, because some families claimed more than one physical effect or they use them together synergistically (either simultaneously or consecutively).

On the other side, the automatic classification has been obtained, running KOM inside the patent class A61L12 and not inside the manually refined pool. The results obtained are shown in Table 5.

² A patent family is a set of either patent applications or publications taken in multiple countries to protect a single invention by a common inventor(s) and then patented in more than one country. A first application is made in one country – the priority – and is then extended to other offices (European Patent Office).

Table 5. Recall and precision for each Ph contained inside the pool of contact lenses sterilization.

PHYSICAL EFFECTS	MANUAL	KOM		PHYSICAL EFFECTS	MANUAL	KOM	
	N° patent family	Rec.	Prec.		N° patent family	Rec.	Prec.
Centrifugal force	2	0,50	1	Electric current	35	0,14	0,71
Pressure	31	0,23	0,29	Electron beam	1	1	1
Vibration	28	0,32	0,82	Magnetic	4	0,40	0,67
Boiling	9	0,44	0,67	Gamma radiation	5	0,40	1
Freezing	1	1	0,50	Laser	7	0,43	1
Gas/steam	36	0,44	0,36	LED	15	0,27	1
Heating	125	0,66	0,88	Microwave	16	0,31	1
Ultrasound	43	0,36	1	Plasma	14	0,21	1
Chemical	1009	0,04	0,77	UV light	50	0,40	0,95
Corona discharge	3	0,67	1				

Results discussion.

The discussion takes into account the comparison between the automatic classification of patents related to the contact lens sterilization and the automatic patent search conducted by KOM. As Table 6 shows, KOM has found 22 physical effects (Ph) for sterilizing contact lenses, identifying all the 19 (Ph)s resulting from manual classification. It has identified also 3 more physical effects (sterilization by burning, infra-red and explosion), but these are false positive results. These results have been obtained because patent texts really mentioned those effects but not to sterilize. In those cases, Natural Language Processing (NLP) tools could be very useful to eliminate irrelevant results.

Table 6. Recall and precision for each Ph contained inside the pool of contact lenses sterilization.

	Manual class.	KOM class.
N° Phs	19	22
Relevant results	19	19

The precision we obtained for each effect is very high, in particular if we consider all the retrieved (Ph)s the average rate of precision is 0,77. This means that, with high probability, patents retrieved for each (Ph) effectively claimed such a (Ph) to sterilize contact lenses. This is achieved by an algorithm that greatly favours precision by reducing recall. Thus, regardless concept expansion on multiple levels (F) and (B) and linguistic expansion, recall remains low because of the way high precision is obtained.

Finally, KOM found some examples of patents classified in more than one (Ph) because they claim different physical effects (Ph). WO9315772: *"A process ... wherein said vessel comprises a collapsible pouch, and wherein said collapsible pouch expands to a visibly apparent distended condition during said irradiating step under the pressure of vapor produced by heating the disinfecting solution to its boiling point"*.

A functional description can be provided at different levels of detail, so it can be described by more than one physical effect (Ph) according to the level of description. A same way to remove bacteria (F) may be described from a general level by an external Behaviour (B) that takes into account one physical effect (Ph), or it may be decomposed in more internal behaviours (B) that interact together (either simultaneously or consecutively), where each internal behaviour (B) is based on one physical effect (Ph). For example, the behaviour of "laser

sterilization" can be described as "local heating", "melting" and "explosion" of zones subjected to the beam.

Chapter 4

Functional approach for formulating problems according to TRIZ contradiction model

This chapter presents how to innovate a product using information extraction from patents literature to identify and overcome TRIZ contradictions. Each initial inventive situation has to be formulated in terms of contradictions in order to use the most effective tool for problem solving provided by the TRIZ theory. The author proposes, (1) an algorithm guiding the user to move from an indefinite problem situation to obtain a clearer problem formulation, following a process inspired to the ARIZ approach for fixing physical contradictions, and (2) some strategies and tools for selecting, acquiring and finally modelling the necessary information to improve the effectiveness in building the contradiction model.

All those strategies have been implemented in a knowledge management tool called KOM (Chapter 5), working as an automatic patent searching engine based on a functional oriented search.

An exemplary application is presented to explain how KOM is integrated in the problem definition process.

A computer aided tool, based on FBS ontology (Gero 1990) is used to define this new problem formulation. Sub-chapter 4.1 presents an overview of some problem typologies existing in literature. Sub-chapter 4.2 collects definitions and examples dealing with TRIZ contradictions. In Sub-chapter 4.3 a four-step algorithm to formulate the problem according to TRIZ is proposed. Sub-chapter 4.4 reports on KOM, a system for knowledge management to support the designer in the contradiction extraction. KOM generates different working directions from the inventive situation, followed by a systematic patent search to identify already known systems that can achieve such working directions. Sub-chapter 4.5 presents an application of the knowledge management strategies proposed by KOM.

4.1. Problem typologies

In the early phase of a design process, the problem space has to be narrowed down in order to transit from an initial situation to a goal state (Newell and Simon 1972). According to Newell and Simon's theory, this space should contain complete information about the initial state of the task (problem), information about the transformation function to move from the problem state to the solution, and information about the goal.

The most widespread classification divides problems into well-defined and ill-structured (Jonassen 1997). Well-defined problems have a definite solution process including a well-known initial state, a defined goal, and they require application of concepts, rules and principles from specific knowledge domains to reach a solution (Jonassen 1997). Unfortunately, in everyday

life it is more frequent to encounter ill-structured problems, in which one or several aspects of the situation are not well specified, the goals are unclear, and there is insufficient information for the problem statement to solve them (Chi, Feltovich et al. 1981).

Problems can also be classified according to similarities in the cognitive process that are required to develop skills for problem solving. In this direction we can cite the works of Getzels (Getzels 1979) and Jonassen's classification (Jonassen 2003) that identified: puzzles, algorithm, story problems, decision making, troubleshooting, diagnosis-solution problems, rule-solving problems, strategic performance, systems analysis, design problems, and dilemma.

Also people from the TRIZ community like Ivanov and Barkan (Ivanov and Barkan 2006) have tried to classify problems in four typologies: manufacturing process problems, design problems, science and research problems, emergency problems.

To complete the overview on problem classification, it is useful to cite also the problem classification proposed by Altshuller (Altshuller 1984). Also this classification is based on the types of information required to solve it. According to him, problems can be classified in two categories, technical problems and inventive problems. We face technical problems when the designer knows where to find the information needed to solve them and how to use such information. Solving this kind of problems leads to a quantitative change of the technique. While, we face inventive problems every time the designer needs solving instruments not yet known in technical literature to achieve a qualitative change of technique.

The growth of interest in ill-defined problems, and consequently in design problem methodologies, has been radically

changing the role of the designer, from a creative person highly skilled in the art, into an expert in design methods and knowledge management techniques. In this scenery, knowledge plays a pivot role in the problem solving activity and this is the reason why in TRIZ community many people have developed methods and tools to retrieve and organize information for contradictions formulation. A class of these methods is based on the cause-effect ontology, methods such as Root Conflict Analysis (Souchkov V. 2005), and other systems dialogue based (Zlotin ; Russo and Birolini 2011; Becattini, Borgianni et al. 2012) guide the user towards a causal decomposition to identify the core of the problem, the contradiction. Other attempts have been done in using different methodologies such as the axiomatic design (Kim and Cochran 2000) or the theory of constraints (Ma and TAN 2007) to better define a contradiction. Other approaches are based on text mining techniques to identify a network of contradictions from patents (Cavallucci, Rousselot et al. 2008) or algorithms for searching similar systems by parameters extraction from text (Verhaegen, D'hondt et al. 2011). In addition, we have those approaches that aim to formulate contradictions according to the functional ontology, among these methods we mention FOS (Litvin 2004) that supports the identification of contradictions by means of a functional searching, tools to model problems by functional analysis (Daniilidis, Eben et al. 2011), automatic systems for extracting functions contained inside patents (Cascini and Russo 2007), and knowledge bases in general (Zlotin and Zusman 2005).

The approach proposed in this chapter aims to formulate a problem in terms of contradiction as a conflict between two systems or two different configurations/working conditions of a same system.

4.2. An overview on TRIZ contradictions

An **inventive situation** is a typical case where the problem does not allow us to use known solving techniques to find a solution, while an invention is needed. Two main conditions define an inventive situation:

- Vagueness of the initial problem. The formulation is so vague that it contains many different problems.

- Contradiction. When we try to find a solution using the prior art, some conflict situations arise. These conflicts are called technical contradictions. In fact, technical systems are whole entities and, any attempt to improve a part (function, characteristic) of the system by known techniques leads to a not acceptable worsening of other parts (functions, characteristics) of the system.

A very representative problem to explain inventive problems is described by Altshuller himself.

Example: *For testing a new type of parachute, a small model of it is used for the simulation. The parachute model is placed in a transparent tube in which a stream of water flows. In this test it is essential to record the motion of vortices of water around all parts of the parachute (cell and suspension lines) by a camera. How to make the vortices visible? We tried to cover the parachute model with a soluble paint, but paint was faded faster and we had to stop testing very often. What to do?*

The formulation is so vague that it contains many different problems, i.e. changing the paint, the way to paint, the investigation system, etc.. The inventive situation consists of a description of the technical system highlighting the deficiencies: the absence of a certain characteristic or vice

versa the presence of an undesired characteristic (harmful). Many difficulties that arise in solving inventive problems are influenced by attempts to resolve the initial situation without consciously moving from the "pile" of problems of the initial situation to a real problem.

According to TRIZ all systems develop themselves as the result of the accumulation of contradictions within the system. The amount of contradictions increases and their solution is possible through a breakthrough, i.e. an idea that comes up, a totally new conception. Consequently, finding solutions to inventive problems, or more in general improving technical systems, must include the identification and resolution of hidden contradictions within systems. The transition from the indefinite inventive situation to the problem and its model is described by Altshuller (Altshuller 1984; Terninko, Zusman et al. 1998; Salamatov 1999; Savransky 2000) through three different types of contradictions.

Administrative contradiction.

Something is required to make, to receive some result, to avoid the undesirable phenomenon, but it is not known how to achieve this result.

Let's take the example of parachute problem that is an administrative contradiction, in other terms it is not a problem but rather an inventive situation. Usually, an inventive situation is formulated like something is required to make (for achieving some result or avoiding the undesirable phenomenon), but it is not known how to do it. This type of contradiction does not contain any direction to address the answer.

Technical contradiction.

An action is simultaneously useful and harmful or it causes Useful Function(s) and Harmful Function(s); the introduction (or amplification) of the useful action or the recession (or easing) of the harmful effect leads to the deterioration of some subsystems or the whole system, e.g., an inadmissible complexity of the system.

The administrative contradiction has to be turned in a technical contradiction, so transforming a given problematic situation into a technical problem. This helps to reduce the vagueness of the inventive situation. In our parachute example, we can formulate the technical contradiction as in the following:

Example: *To increase the time of video shooting is necessary to add significantly the quantity of paint placed on the parachute, but in this way we inevitably alter the measurement and the shape of the model.*

Physical contradiction.

A given subsystem (element) should have the property "P" to execute necessary function and the property "-P" to satisfy the conditions of a problem. Where "-P" could be defined both as the absence of P and the opposite of P.

The physical contradiction implies inconsistent requirements to a physical condition of the same element of a technical system. Each technical contradiction can be expressed in terms of a physical contradiction that represents the final reformulation of an inventive problem. For the example of the parachute the physical contradiction is reported in the following.

Example: *On the suspension lines there must be an infinite amount of paint (to increase the time of video shooting) and there should not be absolutely (not to alter the measurement).*

Problem analysis has always had a pivot role inside the TRIZ community. The transition from administrative contradiction (situation) to technical contradiction (problem) is hard task (Altshuller 1984; Savransky 2000) due to two main reasons:

- Vagueness of the initial situation, among all different problems related to a situation is difficult to choose and define the problem to face.
- Technical contradictions are often hidden inside problem conditions.

In fact, in ARIZ, the most representative and acknowledged tool of the TRIZ theory, the "step 0" dedicated to the problem reformulation has been modified many times until its final elimination. The first version of ARIZ dates back to 1956, but only in the 1964 version, did a section devoted to "clarifying and verifying the problem statement" appear. It remained unchanged until 1968, when the section related to problem analysis was expanded and supported by techniques for overcoming psychological barriers (Size Time Cost - STC tool, etc.). In this version the correct problem identification was almost half the entire algorithm. The versions belonging to the 1970s (ARIZ 71, ARIZ 75, ARIZ 77) had the problem formulation and analysis phase as large and distinct, until obtaining the 1977 version, by successive and gradual changes. ARIZ 77 was based on a single step composed of nine sub-sections, including techniques for reducing psychological inertia, comparison techniques based on existing systems on the market and patents knowledge. Since this

version, the problem formulation stage remained unchanged in the following versions (82-A, B, C, D and 85-A) until version 85-B where it suddenly disappeared. The section on analysis and reformulation of the problem was eliminated, even though it was considered necessary and useful, because it was probably judged too poor in rigor compared to the other steps. Also Altshuller, the founder and creator of TRIZ theory, was not able to find a structured procedure for the formulation of the problem (Zlotin and Zusman 1999). This lack, in a context of a well-structured and guided theory, could not pass unnoticed and without any consequences. In fact, in following years, many TRIZ specialists have tried to bridge this gap. Immediately after 1985, the suspension of ARIZ developments by Altshuller and the need for a structured step guiding the formulation of the problem was perceived and thus proposed by many of his disciples (Terninko, Zusman et al. 1998; Khomenko, De Guio et al. 2007). So, further versions of ARIZ, containing a section on the analysis of the problem, were developed (such as ARIZ-KE-89/90, ARIZ-SMVA 91, ARIZ92, Ariz.-96SS). In more recent years, the arrival of the first computer programs has supported the development of this phase, trying to guide the user in the first phase of problem analysis, especially in information retrieval and problem formulation (Ideation, Invention Machine and Iwint). Before to introduce also our methods for supporting problem formulation in terms of contradictions (Sub-chapter 4.4), a new algorithmic method to formulate a problem as a physical contradiction is proposed in the next sub-chapter.

4.3. From an inventive problem to its contradiction in four steps

As above mentioned, solving an inventive problem means to identify and eliminate the contradiction. Sometimes, the technical contradiction within a problem is clearly evident, other times it seems that a problem does not contain any technical contradiction because it is hidden within the problem conditions. In the following, we summarize in four steps the formulation process of the physical contradiction starting from an initial inventive situation. Where, the physical contradiction represents the most precise way to formulate an inventive problem, because it contains a precise specification of which direction should be taken and which parameters have to be used to model the solution. In particular, this four-step process is derived from OTSM-TRIZ (Cavallucci and Khomenko 2007) and it is based on the clear definition of the initial situation A, followed by the identification of an alternative situation B that can solve the situation A but introduces a new problem and so a contradiction. A schematic representation of the four steps is reported in Figure 15.

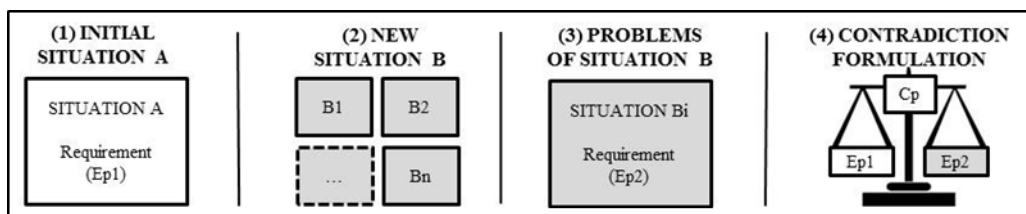

Figure 15. A schematic representation of the algorithm for the problem reformulation.

(1) Initial situation A.

The step 1 aims to clearly define which main requirement the solution must have to solve the initial situation A. This requirement has been called Evaluation Parameter (EP1) (Cavallucci and Khomenko 2007) and it represents the desired improvement (or creation) of a useful function or the decrease (or elimination) of a harmful function.

Initial situation A

System A does not achieve a required function (EP1)

Example: *For the situation of the parachute, the EP1 can be defined as: the time of video shooting has to be long.*

(2) New situation B.

The step 2 aims to identify a new situation B where EP1 is satisfied. New situation B could be defined by already known solutions/systems that can satisfy EP1 improving (or creating) a useful function or decreasing (or eliminating) a harmful function.

New situation B

System A does not achieve a required function (EP1), so it has to evolve to a different system B to achieve the required function (EP1)

Example: *To increase the time of video shooting (EP1) many known solutions are possible:*

- *A new way to paint the model using the existing paint.*
- *A more effective paint to coat the model.*
- *Avoiding the use of paint and building a new device for shooting that can acquire the movement of transparent water.*

Choosing the first situation, where *something has to be changed in the way the existing paint is used*, the new situation B can be defined by an expert as: *adding more paint on the parachute model*.

(3) Problems deriving from situation B.

The step 3 aims to find new problems (EP2) introduced by adopting the system B to satisfy EP1.

Problem of situation B

System B cannot achieve another requirement (Ep2),
that system A was able to satisfy.

Example: *If we add more paint to the parachute model (situation B) the measurement will be affected due to the alteration of the vortices (EP2) or the costs of test campaigns are higher (EP2) or etc.*

(4) Contradiction Formulation.

In the last step, among all requirements/problems (EP2) extracted from situation B, we select only those which are in conflict with the requirement (EP1) of the situation A. Now the technical contradiction could be written in the following way:

Technical contradiction formulation

System A does not achieve a required function (EP1); so
it has to evolve to a different system B to achieve the
required function (EP1),

BUT

System B cannot achieve another requirement (Ep2) that
system A was able to satisfy.

Example: *The technical contradiction is the following: initial system A does not realize a time of video shooting long enough; adding more paint (system B) we realize a longer time video BUT the measurement will be affected due to the alteration of the vortices.*

Finally we have to transform this technical contradiction in a physical contradiction. According to the definition at Chapter 2, we have to find the property "P" to execute the necessary function and the property "-P" to satisfy the conditions of a problem. Such a property is called Control Parameter (CP) (Cavallucci and Khomenko 2007). Here the final template for physical contradictions:

Physical contradiction formulation

PhC#1: the CP has to be high to satisfy EP1, but doing that EP2 is not satisfied.

PhC#2: the CP has to be low to satisfy EP2, but doing that EP1 is not satisfied.

Example: *Physical contradictions are the following:*

- *PhC#1: the quantity of paint has to be high for long time video shooting but doing that the vortexes alteration is high.*
- *PhC#2: the quantity of paint has to be low for a small vortexes alteration but doing that the time video shooting is short.*

4.4. Using functional knowledge to support contradictions extraction and formulation

In this chapter we focus our attention most on the first two steps of the algorithm, (1) defining the initial situation A by the extraction of the requirement we want to satisfy (EP1) and (2) identifying a new situation B where system B satisfies EP1. In fact, there are often several ways for satisfying EP1, and for all these ways it is possible to find a new system B. This new system B satisfies EP1 but it introduces a new problem (EP2), in other terms it generates a contradiction.

For example, thinking about a nutcracker that breaks the shell but it also damages the kernel, system B can be found considering several solution ways as shown in Table 7. Each system B leads to a contradiction.

Table 7. System B generated as a modification of system A.

System B can be found as a modification of system A:	Solution ways
Change Working condition	<i>Breaking nut in a very cold environment in order to weaken shells</i>
Change system Configuration	<i>Modifying the compression force according to the nut shape and dimension</i>
Change Structure	<i>Modifying the levers shape</i>
Change Working principle	<i>Using ultrasound breaking</i>
Change Function	<i>Opening nuts without cracking but by levering</i>

TRIZ theory does not have specific tools for supporting the identification of the situation/system B, so the right identification of the contradiction is totally demanded to the user capabilities and knowledge. We have to use our background or creativity to imagine a system B. Several attempts were done by Altshuller before 1985 to assess a module for overcoming this

problem, called ARIZ step 0, but it was abandoned in the last official version of ARIZ 85C. Litvin (2004) offered a partial answer to this problem by the Function Oriented Search (FOS). Given an initial problem, FOS aims to find a new system that performs the same function. It is a method composed of eleven steps. Table A represents the first seven steps of FOS and their applications; in the last three columns we describe the limitations of that methodology. In particular, the third and fourth columns show which elements are missed by a traditional FOS. The next chapters report on KOM, a system developed by the author to support especially steps 1, 4 and 5 of FOS.

KOM a knowledge searching system to support contradiction formulation.

The Knowledge Organizing Module (KOM) is a functional based search approach developed by the author to extract knowledge from patent database (Russo and Montecchi 2011; Russo and Montecchi 2011). This computer aided system is a searching tool that can be used by who needs to formulate the contradiction finding an already known/patented system B. It is based on the FBS design ontology (Gero 1990), that is introduced to decompose the functional concept in three levels (Montecchi and Russo 2011): function (F), behavior (B) and physical (or chemical) effect (Ph), e.g. "crushing a nut" can be decomposed in "cracking the nut (B) by compression(Ph) for opening it (F)". This decomposition is suggested in order to create functional targets for searching inside patent database and ameliorate search results (Russo and Montecchi 2012). Both in KOM and in FOS, user has to define a function and an object representing the initial situation. The difference is the way KOM searches inside the patent database. KOM does not use directly the

function and the object provided by users but it processes these two elements by two actions: (1) a functional description of the main function into behaviours and physical effect according to the FBS theory and the other functional approach presented in chapter 2, (2) a semantic expansion of all the functional targets generated by the previous action.

Table A. The contact lens sterilization problem by FOS approach. The last three columns describe limitations and suggestions.

FOS: steps 1-3	FOS: case study	FOS: shortcomings	Shortcoming examples	Tools and References
1. Identifying the key problem to be solved.	1. Contact lenses must not be contaminated.	1. Defining EP1 is not a simple task due to the complexity of the initial situation and its vagueness. Often, an initial situation contains more than 1 key problem, and these key problems can be translated in more functions.	<p>Potential alternative key problems:</p> <ul style="list-style-type: none"> • Sterilizing lens preventing their corrosion. • Finding an alternative way to sterilize. • Avoiding infection of the eyes. • ... 	<p>Functional decomposition according to the FBOS theory:</p> <ul style="list-style-type: none"> • D. Russo, et al. (2011), (2011). • D. Russo and T. Montecchi (2011), (Russo and Montecchi 2011; Russo and Montecchi 2011).
2. Articulating the specific function to be performed.	2. Sterilize contact lenses.			
3. Formulating the required parameters and constraints.	3. The effectiveness of the sterilization process is measured by SAL. For the medical field, SAL<10 ⁶ (the microbial population has to be reduced from 1 million to 1 unit). In this process the lenses must not be damaged and/or changed their mechanical structure.			

FOS: steps 4-7	FOS: case study	FOS: shortcomings	Shortcoming examples	Tools and References
4. Generalizing the function.	4. <i>Remove bacteria from contact lens surface</i>	4. How to generalize the function?	<i>e.g. to disinfect, clean, remove, etc.</i>	Hypernymy relation: WordNet (Fellbaum 2010)
5. Identifying Leading Areas (industries or science branches).	5. <i>One leading area is the sterilization of medical devices, (surgical instruments). It has the same generalized function.</i>	5. People skilled in the art often identify existing systems using their background and experience, but personal knowledge is limited and the number of alternative solutions we can know is limited too, moreover we often search them in our field of expertise.	<i>e.g. existing solutions to sterilize hydrogen peroxide, peroxyacetic acid and all the other chemical solutions, vapour, aerosol spray, thermal treatment (overheating, boiling, freezing, etc.), high pressure, plasma, ultrasound, UV light, etc. How many others solutions do already exist to remove bacteria? Is the sterilization used in other fields? If yes, which?</i>	Methods and tools to identify already known solutions: <ul style="list-style-type: none"> • <i>Pointers to effects (Salamatov 1999; Savransky 2000).</i> • <i>Manually browsing prior arts.</i> • <i>Knowledge Organizing Module (KOM): a searching system able to automatically identify already known systems in patent literature (Russo and Montecchi 2011; Russo and Montecchi 2012).</i>
6. Identifying the best experts and/or institutions in the Leading Areas.	6. <i>Johnson & Johnson (New Brunswick, New Jersey)</i>			
7. Identifying the best existing technologies that perform a similar function in leading industries by using experts, industry registers and databases.	7. <i>Vapour sterilization has a very high effectiveness in removing bacteria without damaging polymeric surfaces.</i>			

In this way the initial user's query is so transformed in a set of queries, one for each physical effect contained in our physical effect library. Every query could produce a potential system B, differing from system A for its physical effect and suitable for completing our contradiction. At present this kind of semantic search is able to automatically associate the concept of *cracking nut* with other linguistic variations as "*opening or compressing a nut*".

Like in FOS, KOM can search documents inside our field of interest (e.g. *cracking the nut*) or outside (e.g. *shellfishes cracking, eggs cracking, tablets cracking, etc*). Searching outside our field allows us to gain a more exhaustive view of the existing systems that can achieve the desired function (EP1). In fact, external fields can disclose new solutions based on the exploitation of new physical effects not yet developed in our field.

After having chosen the known system B, now we have to identify problems (EP2) related to this situation B. Also in this case, KOM can be very useful since it is able to individuate and classify (according to their fields) the entire pool of all the patents that allow us to achieve a same goal. Once we have the collection of pertinent patents we can also use text mining techniques to automatically extract problems (EP2) from texts by the recognition of predefined linguistic patterns that imply technical problems (Cascini and Russo 2007; Liang, Tan et al. 2008).

Finally to build the physical contradiction model, we need to identify the control parameter (CP). At present, some attempts are done in trying to automatize the extraction of control parameters (CP) by means of text mining techniques (Zanni-Merk, Cavallucci et al. 2009). These text mining techniques are based on linguistic markers that can locate the control parameter (CP). In particular, a parameter can be retrieved using verbs that introduce a concept of change such as, "change, generate, enable, create, enhance, improve, stabilize, maintain, emit" and also considering, for each specific verb, the syntactic role of the parameter.

4.5. Case study

This case study shows the potentiality of retrieving and structuring the proper knowledge for building TRIZ contradiction model by means of a functional approach.

Problem: *We want to shell walnuts to be sold, to do that, it is essential to keep intact their kernels. How can we extract the kernel keeping it intact? We tried to crack the walnut by a traditional levers nutcracker, this works for most of the walnuts, but in some cases the force generated is excessive and kernel is broken. What to do?*

(1) Initial situation A.

The author has explored and proposed different directions of solution for keeping integer the kernel (EP1).

Initial situation A
Traditional nutcracker cannot maintain integer the kernel (EP1)

To do that, we exploit the laws of evolution (Russo, Regazzoni et al. 2011), and combine different functional approaches (chapter 2). In this case, the aim is to generate a wide range of directions of intervention at a general level, described in functional term. In this case the application of KOM method splits the initial situation into several EP(s), as shown in Figure 16.

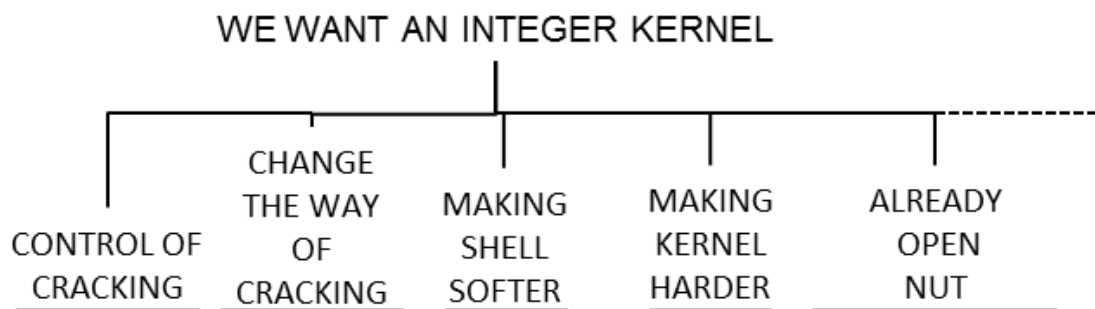

Figure 16. Different directions of intervention to keep integer the kernel of a nut. Directions generated by KOM method.

Before moving to the next step, the user has to choose only one of these alternatives to satisfy EP1 according to TRIZ evolution laws. Among these ways we choose "to change the way of cracking".

(2) New situation B.

This step aims to find, in patent DB, all alternative systems B "to sterilize contact lenses" in a different way from the initial one. In this case we are looking for systems differing by the physical effect (Ph) (Russo and Montecchi 2012). KOM works operating two actions:

1. Functional decomposition in Phs. It searches for alternative ways of cracking such as mechanical, thermal, acoustic, chemical, electric and magnetic sterilization.
2. Terms expansion of functional targets: "cracking" is automatically associated to "fracturing", "dividing" and "opening". Furthermore a semantic expansion module searches all linguistic variations of any term composing the query (e.g. "to crack" is also searched as *crack-s*, *-ed*, *-ing*, *-er*, etc.)

Figure 17 shows a map of the different ways for cracking walnuts found through the functional search conducted by KOM, in particular different ways are different physical effects. For every branch a list of patents is automatically provided. KOM identifies a pool of patents for every branch, but only one patent is then shown in the map. This allows to clearly visualize both which are the Phs already implemented at the state of art (if the patent search is limited to a specific area) and which Phs have been exploited in all the patent DB (for no limited searches). KOM offers several ways to manage such an extensive search (Montecchi and Russo 2011).

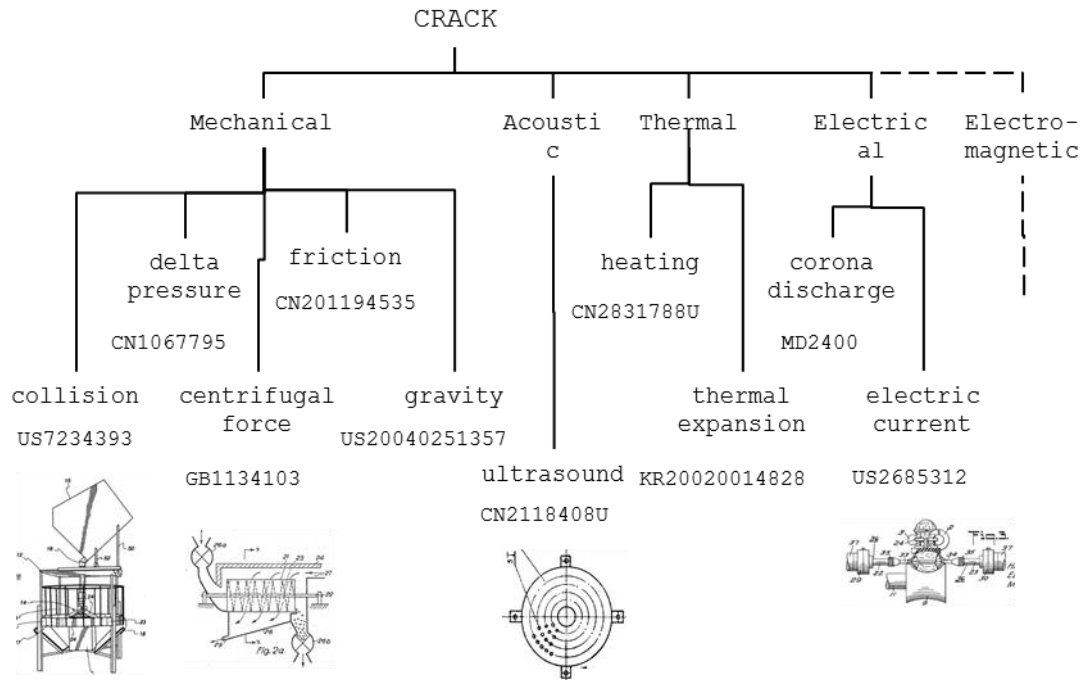

Figure 17. Known solutions based on different physical effects to crack a walnut. Results generated by KOM searching inside patents of nutcracker domain.

If we extend this search of known systems outside the nutcracker domain, KOM can identify other fields:

- Cracking shells in general: devices for cracking shellfish or shell eggs or gas tank shell, etc.
- Cracking object in general: machine for cracking tablets or stones, devices for grinding rice or grain, etc.

KOM has found also some examples of physical effects, not yet exploited at the state-of-the-art of the nutcracker but, already developed in other fields, e.g. JP2005312315: using vibrations for eggs cracking. Similarly, KOM could be used to generate a different situation B, at a more abstract level as in example: "Finding a new way of opening walnuts". See Figure 18.

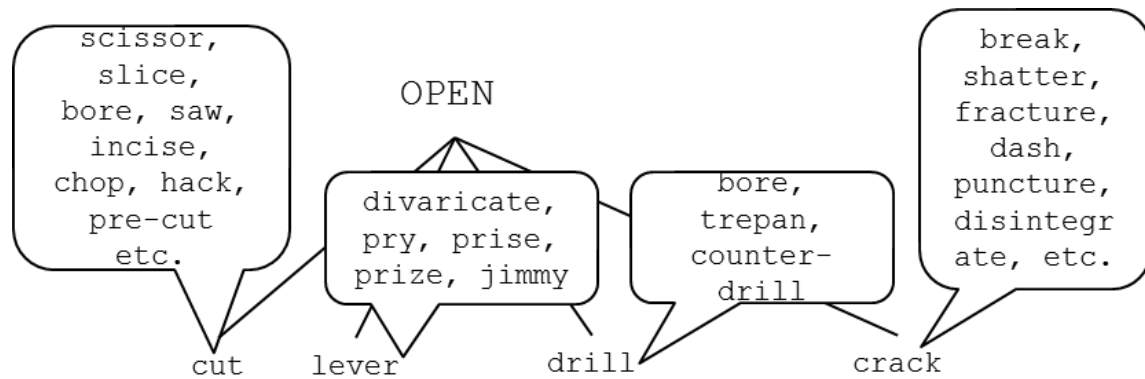

Figure 18. Alternative situations of opening walnuts.

Finally KOM can be used to suggest the new situation B at the structure level. Just processing the pool of patents suggested at the bottom of every single branch of the diagram (Fig. 17), we can understand, if there are known solutions that have already tried to achieve our EP1. Simple text mining tools, such as those developed by Cascini and Russo (Cascini and Russo 2007) can automatically search comparative and superlative adjectives to identify known systems satisfying EP1.

Figure 19 shows three ways of using levers for mechanically cracking a nut.

- EP976355: "The nutcracker device according to the invention may comprise ... and second stop means limiting the minimum distance between said elements".
- US4944219: "This nutcracker is provided by more than two levers, so in this way the cracker force and inertia can be controlled easier".

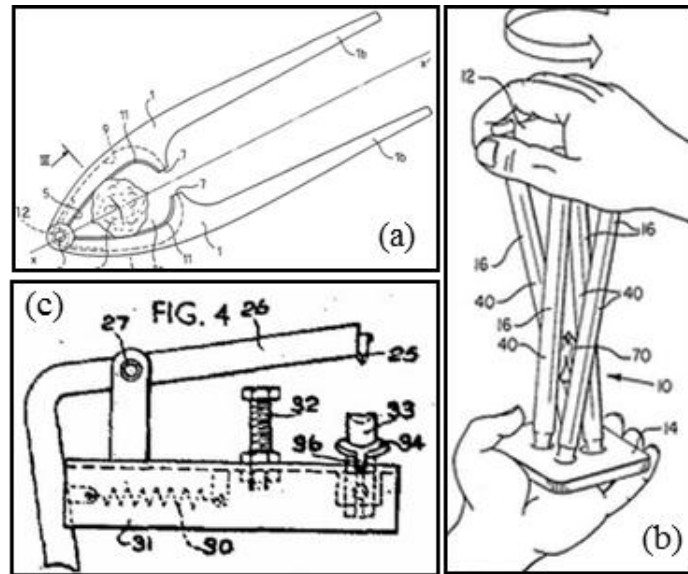

Figure 19. Examples of different structures used to crack walnuts by compression without damaging kernels. (a): EP976355, (b): US4944219, (c): GB1152001.

Among the known solution identified by KOM, we decide to choose the nutcracker having a stop "to keep the kernel undamaged" (EP1)

New situation B

Traditional nutcracker cannot maintain integer the kernel (EP1),
 so
 it has to evolve to a nutcracker having a stop in order to
 maintain integer the kernel (EP1)

(3) Problems deriving from situation B.

Now we have to identify problems (EP2) related to this situation B: a nutcracker having a stop (in order "to keep the kernel undamaged"). Searching within patents we have found the following problem: CN201814442U - "Therefore, the people have invented various walnut pliers according to actual nut, but the walnut pliers size in market is fixed, mainly designs in view of some big walnuts, but regarding the present great variety, a nutritional value higher small walnut, carya and so on cannot give dual attention".

Problem of situation B

Nutcracker with the stop cannot crack small walnuts (EP2),
 that traditional nutcracker was able to crack.

(4) Contradiction Formulation.

From the previous step (3) we have obtained EP2, so now the technical contradiction can be formulated like:

Technical contradiction formulation
<p>The initial nutcracker does not keep the kernel undamaged (EP1); evolving to a nutcracker having a stop (system B) the kernel is undamaged (EP1),</p> <p style="text-align: center;">BUT</p> <p>The small size walnuts cannot be cracked (EP2) while the initial nutcracker was able to do.</p>

The physical formulation assumes this form (the CP is the height of the stop):

Physical contradiction formulation
<p>PhC#1: the height of the stop as to be high to keep the kernel undamaged, but doing that the small size walnuts cannot be cracked.</p> <p>PhC#2: the height of the stop as to be low to crack the small size walnuts, but doing that the kernel is undamaged.</p>

CP, EP1 and EP2, allow the designer to obtain a very precise model of the initial problem situation. This formulation of the problem has reduced the initial vagueness, easing the generation of effective solutions.

Chapter 5

KOM a conceptual patent search engine for supporting functional search

During this research activity a tool for information extraction from patents was developed. This tool is called KOM (Knowledge Organizing Module) and it has been created to support the research of functional targets (Chapter 2). In particular, in this thesis KOM has been applied as a support for the decision making (Chapter 3) and problem reformulation (Chapter 4). KOM uses a concept-based search that is proposed as an alternative to the most widely used search based on keywords. In fact, linguistic heterogeneity of patent language makes patent searches by keywords a challenging task. In the following, an overview of the main limits related to the keyword-search on patents without any claim to completeness:

- **Different detail levels of patent descriptions.** Every inventor has his own style, and the same concept could be expressed at different detail levels (at abstract level by means of a generic language, while at specific level by technical terms and a very precise language). The main reasons are two, on one side people coming from different areas (technical field, geographical, cultural background, etc.) use different expressions and so different words to express the same concept. On the other side, patentees follow different strategies for writing patents, and sometimes they purposely use very vague or inconsistency terminology for hiding patent content or extending claims validity.

- **Inaccurate terminology.** Patentees often give words a different meaning from their ordinary dictionary definition, using non-precise or wrong words and in some cases they even create new terms to describe their inventions. Moreover, lack of standard names for developing technologies, devices or machines lead to use many different terms. Finally, in case that a function is obtained by a logical sequence of actions, patent writers could totally or partially omit them, just using one instead of all, or simply citing the most general. For example, "a laser beam lighting a surface to generate both an overheating and a chemical decomposition, so causing a localized ablation" can be otherwise expressed just by "laser cutting".
- **Polysemy.** Same keywords may have different meaning according to different fields, such as the terms "windows", it can indicate a framework enclosing a pane of glass, an operative system, a time gap, etc.
- **Different official languages.** Patents coming from different patent offices can be written in different languages or they can be machine translated but their translations could be incorrect.
- **Acronyms and abbreviations.**
- **Different spelling.** A given language could have a different spellings to describe a single term, such as sterilize/sterilize, or aluminum/aluminium. Moreover, even spelling errors may be contained inside patent texts.

This list of shortcomings is not complete, but it allows us to understand why a patent search based on keywords cannot be considered exhaustive.

Even if we were able to define every kind of linguistic relationship, searching for functional information is very challenging. This is because in most cases patents are not written in a functional language. For such a reason only a radically different approach can recognize a specific function independently on how it is expressed in patent text. Design methodologies are combined together with a text mining techniques using semantic tools. In this chapter the algorithm of KOM for searching functional targets is presented (Sub-chapter 5.1). In Sub-chapter 5.2 a case study shows how KOM works.

5.1. KOM a concept-based tool for searching patent

KOM uses a concept-based search that extracts the concept behind the user queries and returns results matching information based on not only the keywords directly used in the initial query (Lin, Graydon et al. 2004). To do that, knowledge bases are used to expand the initial query. The more expanded is the query, the higher is the recall but precision can drop. For limiting non pertinent patents, semantic tools (such as tagger, parser, etc.) can be introduced. Figure 20 represents KOM's algorithm for the conceptual search tool. Steps (rectangles), input and output (arrows) are shown.

KOM patent search engine

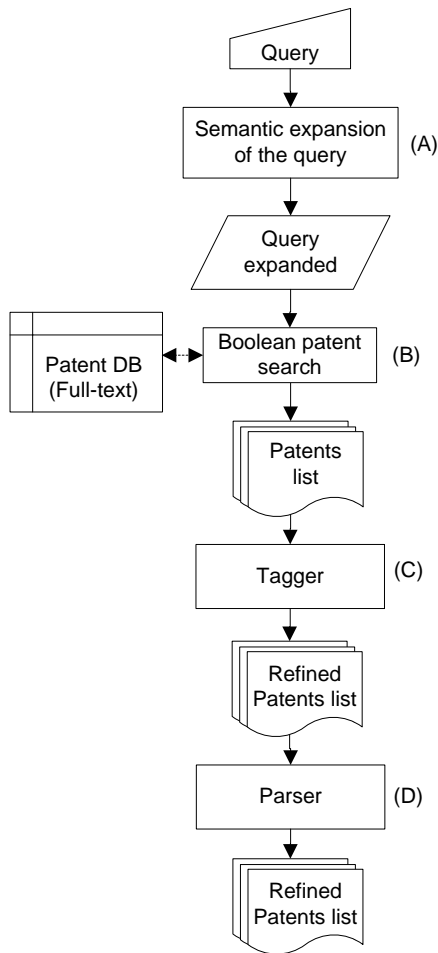

Figure 20. Algorithm of KOM, a patent search engine based on conceptual search.

In the following, the functioning of the concept-based algorithm is presented step by step.

(A) Semantic expansion of the query.

Patent language can be extremely various and a same concept can be expressed differently. So, in order to increase the recall of our search, the initial query is expanded adding more possible terms with which a patentee may express the same concept. This expansion is based on semantic relations contained inside pre-built knowledge bases, such as dictionaries, technical thesauri or even design methodologies (Russo and Montecchi 2011; Russo and Montecchi 2011). In the following, an example is provided dealing with the expansion of "bicycle" and "light". They can be used as keywords for searching systems for lighting the pedals of a bicycle through LED devices.

- **Synonyms.** Bicycle can also be expressed by "bike", "wheel" and "cycle" while "illuminate", "illumine", "light up" and "illuminate" are synonyms of "light". Furthermore, also acronyms can be considered in this category. For example using "light-emitting diode" instead of LED is the only way to retrieve document US5662405 that never uses "LED".
- **Correlated terms.** They are terms that express the same concept to a more general or specific level, e.g. "wheeled vehicle" is a more general way for "bicycle" and "vehicle" or "transport" are even more general, while "tandem, mountain-bike, velocipede" are more specific. The user can choose the expansion of the concept, acting on the distance that correlated words have to have from the initial keyword, in other terms, the user can select how much the concept needs to be generalized and specified.
- **Morphological variants.** A same term can appear in a text in different forms. For example, a noun can be expressed in the singular or plural form (e.g. "bicycle" or "bicycles"), and a verb by all its forms (e.g. "light" or "light-s, -ing, -ed");
- **Syntactic variants.** A same concept can be expressed by different syntactic categories. For example, the concept "an object lighting ..." could be expressed by different forms: a functional verbal form ("an object lights ..."), an adjective ("a lighting object for ..."), a paraphrase ("an object able to light ..."), a noun ("lighting") indicating the result of the action on the object, an adverbial form, etc.

(B) Boolean patent search.

KOM database contains more than 40 million of patent documents having always at least both title and abstract in English. The output of this step is a list of patent families³ that match the initial query by means of a Boolean search. If possible, we perform these searches on the full-text (fields: title, abstract, descriptions and claims), instead of using only some of these fields. Using full-text allows us to increase recall of patent search and the possibility to obtain all the relevant PCs. In order to demonstrate how a full text search may affect final results, Table 8 shows the number of documents obtained with the same query («pedal AND bicycle AND led») performed on different fields of patents. The research was manually carried out on a pool of 40 families related to the LED for the lighting of bicycle pedals.

Table 8. Number of patent families retrieved by a patent search conducted processing different combination of patent fields.

Query	Retrieved patent families			
	Ti	Ti+Ab	Ti+Ab+Clms	Full-text
«pedal AND bicycle AND led»	2	17	23	30

(C) Tagger.

Polysemy of words is the capacity of some terms to have multiple meanings. It directly affects precision. For example, if we search “nut” thinking as a small hard fruit, we will also retrieve nut and bolt. In this step, the list of patents obtained by the patent search (step B) is processed by a tagger in order to understand the different grammatical categories of words (noun, verb, adjective, etc.). For example, if we use the query «pedal AND bicycle AND led» (see Table 9) for searching PCs related to the illumination of bicycles’ pedal by LED technology, a tagger can find many patents where “led” is used as verb instead of noun..

³ A patent family is a set of either patent applications or publications taken in multiple countries to protect a single invention by a common inventor(s) and then patented in more than one country. A first application is made in one country - the priority - and is then extended to other offices (European Patent Office).

Table 9. Patent analysis output provided by the Stanford POS tagger (Toutanova, Klein et al. 2003) to disambiguate the term "led".

Patent	Input tagger	Output tagger	Keywords role
EP1728712	<i>A brake rod (14) is led through the housing, and a separable brake coupling is provided in the housing between the brake rod and the axle.</i>	A/DT brake/NNP rod/NN (/LRB 14/CD)/RRB is/VBZ <u>led/VBN</u> through/IN the/DT housing/NN ,/, and/CC a/DT separable/JJ brake/NP coupling/NN is/VBZ provided/VBN in/IN the/DT housing/NN between/IN the/DT brake/NP rod/NN and/CC the/DT axle/NN	Led as verb (to lead)

In this specific case, the word led is associated to the tag VBN "Verb, past participle" (Santorini 1990) because it is a verb, while the tag NP "Proper noun, singular" is used for a noun). Thus, tagger can be used to eliminate irrelevant patents, like the patent EP1728712. Unfortunately, situations like this are very frequent and results of patent search if based only on keywords can be totally compromised. In this case, if we search «pedal? AND bicycle? AND led?⁴» in title and abstract, we obtain 51 patent families, 19 of which are non-relevant. Thus tagger improves the precision of this patent search from 0.33 to 0.53.

(D) Parser.

Parsing or syntactic analysis is the process of analyzing a string of symbols, either in natural language or in computer languages, according to the rules of a formal grammar. It recognizes the role of each word and the relationships between words inside text. Figure 21 shows an example of a relevant patent containing the words bicycle, pedal and LED lamp that are semantically related. Parser can be used to identify semantic relationships between keywords (such as subject-verb, verb-object, subject-verb-object, etc.) in order to identify and eliminate those documents containing all the desired keywords but having a wrong meaning because keywords can belong to different phrases, or even if in the same sentence they are not related together by the correct relationship.

⁴ Symbol ? is a truncation replacing zero or one character.

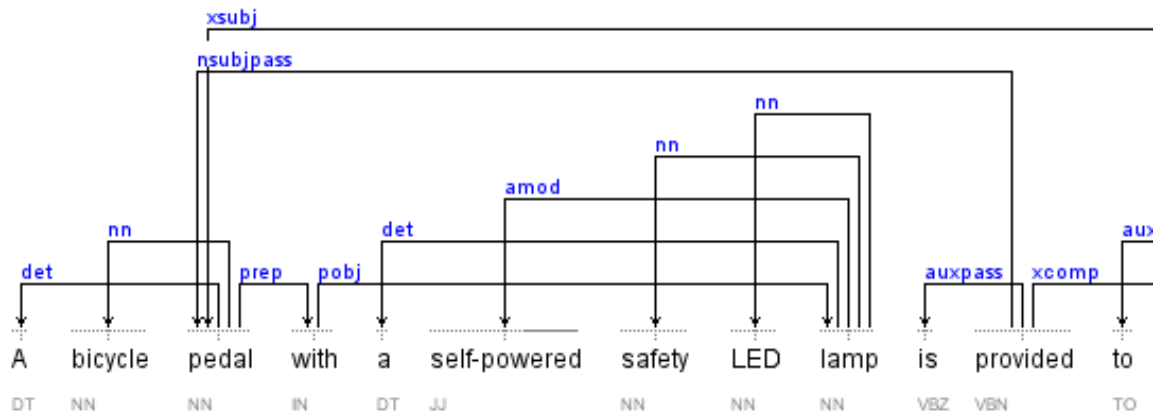

Figure 21. Semantic relations diagram: output of the Stanford parser (Marneffe, Maccartney et al. 2006).

Table 10 shows three examples dealing with «pedal AND bicycle AND led» query processed by a parser. CN201761617 satisfies the desired meaning because the relations pedal-bicycle and led-pedal are contained inside the text, while other documents do not include both those relations so their meaning is not correct. In fact, the documents KR20100084784 and JP2004284563 describe a system having LED but not used for pedal of bicycles.

Table 10. Example of documents resulting from the query: «pedal? AND bicycle? AND led?» and containing different semantic relations between terms of the query.

Pat. Number	Text	Semantic rel.	Pertinence
CN201761617	<i>The utility model relates to a <u>bicycle pedal</u> with a warning function. ... The <u>pedal</u> is characterized in that: six light-emitting diodes (<u>LED</u>) lights 2 are respectively arranged at the left side and the right side of the <u>pedal</u>...</i>	pedal - bicycle led - pedal	Pertinent
KR20100084784	<i>A <u>bicycle</u> sports device includes: a wheel and a <u>pedal</u> which are installed at a frame; a handle part (500) which is installed at the frame; a receiving portion (600) which is installed at the handle part; a vibration sensor which is installed at the receiving portion; and an <u>LED</u> illumination which is installed at the receiving portion.</i>	pedal - bicycle	Non-pertinent
JP2004284563	<i><u>Led</u> unit for <u>bicycle</u> power generation light source. ... To eliminate intentional no-light traveling and insufficient illumination by low-speed traveling, because loads of a generator make a <u>pedal</u> heavy.</i>	no explicit relations	Non-pertinent

Using a parser we can improve the precision of a patent search. For example, if we use the query «pedal? AND bicycle? AND led?» we find 51 patent families, where 34 out of them are irrelevant, so the precision of results is 0.33. If we process these 51 families by a KOM parser the precision in finding relevant documents is improved from 0.33 to 1, in other terms in this case all patents are relevant. In some case, when a parser is not able to identify correct relations between words, thus it can eliminate even some relevant documents.

5.2 Case study

In this chapter, we present the functioning of KOM applied to the sterilization of contact lenses. The specific goal is to find all CPCs that contain at least one pertinent patent and compare results with those obtained by prior art tools. In the following the steps of the algorithm are shown according to the diagram of Figure 20.

(A) Semantic expansion of the query.

The conceptual search is based on lexical and semantic knowledge bases. Table 11 represents the expansion of the initial keywords.

Table 11. Suggested words from KOM knowledge bases for expanding the initial query «sterilize contact lens».

	Sterilize	contact lens
Synonyms	sterilise	contact
Correlated terms	disinfect, sanitize, sanitise, hygienize, hygienise, clean, make clean, cleanse, cleanup, autoclave, antisepticise, chlorinate	lens, lense, optical device
Morphological variants	sterilize, sterilizes, sterilized, sterilizing	contact lenses
Syntactic variants	sterilization, sterilant, sterilizer, sterile	

Lexical and semantic knowledge bases are integrated together inside our tool with the aim to expand the initial query. The initial query can be expanded according to synonyms, correlated terms, morphological and syntactic variants, see Figure 22. Each time the query is expanded using one or more of these functionalities, the user can instantaneously obtain a feedback about the effectiveness of the expansion proposed. In fact, this software launches the query on the patent database of the World Intellectual Property Office and the user can check the results and eventually refine the query expansion manually.

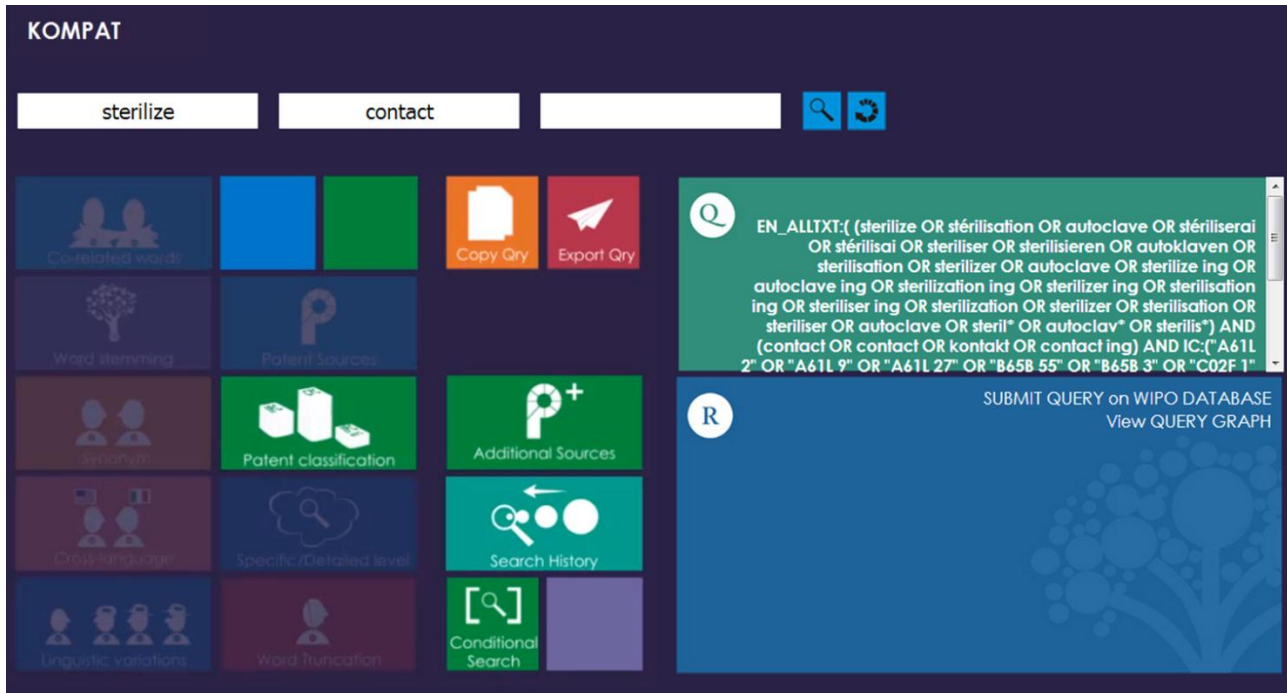

Figure 22. KOM patent search engine. Screenshot of the module for the linguistic expansion of the initial keywords.

If we search with the initial keywords inside the IPC A61L12 that contains only patent related to the sterilization of contact lenses we can find 238 patents of 1,207 (identified by a manual procedure). While if we use the proposed expansion we find 994 patents.

(B) Boolean patent search.

Query of the step A is prepared for searching inside the full-text of patent documents. Table 12 shows the query used for the Boolean patent search at step B.

Table 12. Partial query used for the Boolean patent search of step B.

Search on: entire patent DB
«FULL-TEXT\ (sterilize OR sterilizes OR sterilized OR sterilizing OR sterilization OR sterilizations OR sterilant OR sterilants OR sterilizer OR sterilizers OR sterile OR sterilise OR sterilises OR sterilised OR sterilising OR sterilisation OR sterilisations OR steriliser OR sterilisers OR disinfect OR disinfects OR disinfected OR disinfecting OR disinfection OR disinfections OR ...) AND (contact lens OR contact lenses OR contact OR contacts)»

(C) Tagger.

In Table 13, the query at step C integrates semantic tags. Tagging tool processes only the pool of patents obtained as output from the step B.

Table 13. Partial query used by the tagger for searching on patent documents obtained from the step B.

Search on: patent documents in output from step B
«((sterilize OR sterilise OR disinfect OR ...)/VB OR (sterilizes OR sterilises OR disinfects OR ...)/VBZ OR (sterilized OR sterilised OR disinfected OR ...)/VBN/JJ OR (sterilizing OR sterilising OR disinfecting OR ...)/VBG OR (sterilizing OR sterilization OR sterilant OR sterilizer OR sterilising OR sterilisation OR disinfecting OR disinfection OR ...)/NN/NP OR (sterilizations OR sterilants OR sterilizers OR sterilisations OR disinfections OR ...)/NNS/NPS OR (sterile OR ...)/JJ) AND ((contact lens OR contact OR lens OR lense OR optical device OR ...)/NN/NP OR (contact lenses OR contacts OR lenses OR optical devices OR ...)/NNS/NPS)»

Many patents have been found due to the query expansion, but most of them are irrelevant. The aim of the step C is to eliminate irrelevant patents. In this particular case, the tagger has eliminated the 80% of documents previously found at the step B. The eliminated documents contain keywords used with undesired meaning ("contact" used as verb, or other linguistic paths such as "in contact", "contact with", "contact of", etc.)

(D) Parser.

A new query (see Table 14) is needed for parsing the list of patents obtained in output from the tagger.

Table 14. Partial query used by the parser for searching on patent documents obtained from the step C.

Search on: patent documents in output from step C
«((sterilize OR sterilizes OR sterilized OR sterilizing OR sterilise OR sterilises OR sterilised OR sterilising OR disinfect OR disinfects OR disinfected OR disinfecting OR ...) AND (contact lens OR contact lenses OR contact OR contacts OR lens OR lenses OR lense OR optical device OR ...))/VERB-OBJ OR ((sterile OR ...) AND (contact lens OR contact lenses OR contact OR contacts OR ...))/NOUN-ADJ)»

In this case, the parser has eliminated over than 98% of documents resulting from the tagging process. The eliminated documents contain the keywords of the expanded query but they do not match the concept behind

the query because the semantic relations between words were not meet, e.g. the document WO2012128981 contains the terms "sterilized" and "contact lens" but it does not match the desired meaning "Representative examples of medical goods include but are not limited to sterilized pads, wound aid agents or the like; contact lenses; pills and other pharmaceutical agents and the like".

Chapter 6

Conclusions

The present thesis proposes a function-oriented search from patents. The novelty of this work consists of using functional methodologies coming from design to support patent searches. In particular, this function-oriented search is based on the identification of research targets derived from a selection of these functional approaches. The proposed functional search has been applied in product development to help designers in gaining proper knowledge for:

- Decision making. We have decided to support the decision making process providing some information related to if and how a specific product or technology can be innovated. For this purpose, we have proposed two patent diagrams mapping three main information about (1) the state of the art of already patented products, (2) the identification of directions of development not yet patented in our field (white spaces opportunities) and (3) if exist some examples of patents describing these directions in other technological fields (for a technological transfer activity).
- Problem solving. We have decided to support problem solvers in formulating problems in terms of a conflict between two requirements (TRIZ contradiction). In particular, the formulation of contradiction we propose is based on a process for retrieving and structuring the proper knowledge in terms of functional language.

This research activity is not to be supposed completed. In fact, a more exhaustive analysis of functional approaches coming from design to support patent search is needed. Moreover, one of the main challenges

encountered in this work was the difficulty to evaluate which of these functional approaches are the most promising to support the function-oriented search. In fact, the existing patent search tools based on keywords cannot be used to conduct the proposed functional search. Different research targets need different text mining techniques. This has led the author to develop KOM, a concept-based search tool fully dedicated to searching for the proposed functional targets. This activity took the last year of this doctorate. For what concerns the evaluation of the effectiveness of functional approaches in supporting patent searches, at present, we have only evaluated the performances of searching Physical Effect (derived from FBPhS). This evaluation was related to identify all physical effects used for cracking a walnut and the result is that KOM has found all 19 physical effects previously identified with a manual search (recall=1), see sub-chapter 3.4.

In addition, KOM gives a further useful result, time consuming in performing these functional searches is drastically reduced: from hours, using an integration of different text mining modules, to minutes with a fully dedicated tool.

Bibliography

- Altshuller, G. S. (1984). Creativity as an exact science, Gordon and Breach Science.
- Becattini, N., Y. Borgianni, et al. (2012). "Model and algorithm for computer-aided inventive problem analysis." Computer-Aided Design **44**(10): 25.
- Cao, G. and R. Tan (2007). "FBES model for product conceptual design." International Journal of Product Development **4**(1): 22-36.
- Cascini, G. and D. Russo (2007). "Computer-aided analysis of patents and search for TRIZ contradictions." Int. J. Product Development **4**(1/2): 52-67.
- Cavallucci, D. and N. Khomenko (2007). "From TRIZ to OTSM-TRIZ: addressing complexity challenges in inventive design." International Journal of Product Development **4**(1): 4-21.
- Cavallucci, D. and N. Khomenko (2007). "From TRIZ to OTSM-TRIZ: addressing complexity challenges in inventive design." International Journal of Product Development **4**(1/2): 17.
- Cavallucci, D., F. Rousselot, et al. (2008). Representing and selecting problems through contradictions clouds - Computer-Aided Innovation (CAI). G. Cascini, Springer Boston. **277**: 43-56.
- Chakrabarti, A., P. Sarkar, et al. (2005). "A functional representation for aiding biomimetic and artificial inspiration of new ideas." AI EDAM: Artificial Intelligence for Engineering Design, Analysis, and Manufacturing **19**(2): 113-132.
- Chandrasekaran, B. (2005). "Representing function: Relating functional representation and functional modeling research streams." Artificial Intelligence for Engineering Design, Analysis and Manufacturing **19**(2): 65-74.
- Chi, M. T. H., P. J. Feltovich, et al. (1981). "Categorization and representation of physics problems by experts and novices*." Cognitive science **5**(2): 121-152.
- Collins, J., B. Hagan, et al. (1976). "The failure-experience matrix—a useful design tool." Journal of Engineering for Industry **98**: 1074.
- Daniilidis, C., K. Eben, et al. (2011). "A functional analysis approach for product reengineering." Procedia Engineering **9**(0): 270-280.
- Fellbaum, C., Ed. (2010). Wordnet: An Electronic Lexical Database, Bradford Books.

- Gero, J. S. (1990). "Design prototypes a knowledge representation schema for design." AI MAGAZINE **11**(4).
- Gero, J. S. (2002). Categorising Technological Knowledge From a Design Methodological Perspective, Conference Technological Knowledge: Philosophical Reflections. Boxmeer, the Netherlands.
- Gero, J. S. and M. A. Rosenman (1990). "A conceptual framework for knowledge based design research at Sydney University's Design Computing Unit." Artificial Intelligence in Engineering **5**(2): 65-77.
- Getzels, J. (1979). "Problem finding: A theoretical note." Cognitive Science **3**(2): 167-172.
- Hirtz, J., R. B. Stone, et al. (2002). "A Functional Basis for Engineering Design: Reconciling and Evolving Previous Efforts." Research in Engineering Design - Theory, Applications, and Concurrent Engineering **13**(2): 65-82.
- Ivanov, G. and M. Barkan (2006). "Process Management Using Systemic Thought Process: Identification and Formulation of Creative Tasks." <http://www.triz-journal.com/>.
- Jonassen, D. H. (1997). "Instructional design models for well-structured and III-structured problem-solving learning outcomes." Educational Technology Research and Development **45**(1): 65-94.
- Jonassen, D. H., Ed. (2003). Learning to Solve Problems: An Instructional Design Guide. San Francisco, Pfeiffer.
- Khomenko, N., R. De Guio, et al. (2007). "A framework for OTSM? TRIZ-based computer support to be used in complex problem management." International Journal of Computer Applications in Technology **30**(1): 88-104.
- Kim, Y. S. and D. S. Cochran (2000). "Reviewing TRIZ from the perspective of Axiomatic Design." Journal of Engineering Design **11**(1): 79-94.
- Kingsbury, P. and M. Palmer (2003). PropBank: The Next Level of TreeBank. Treebanks and Linguistic Theories, (TLT 2003), Växjö, Sweden.
- Krishnan, V. and K. T. Ulrich (2001). "Product development decisions: A review of the literature." Management Science **47**(1): 1-21.
- Liang, Y., R. Tan, et al. (2008). Patent Analysis with text mining for TRIZ. 4th IEEE International Conference on Management of Innovation and Technology, Bangkok.
- Lin, A. D., P. J. Graydon, et al. (2004). Concept-based search and retrieval system, SCIENCE APPLIC INT CORP: 31.

- Litvin, S. (2004). New TRIZ-Based Tool-Function-Oriented Search (FOS). ETRIA Conference TRIZ Future 2004, Florence, Italy.
- Lupu, M., K. Mayer, et al., Eds. (2011). Current Challenges in Patent Information Retrieval. The Information Retrieval Series.
- Ma, L. and R. TAN (2007). "Contradiction discovery and solving method based on TRIZ evolution theory and TOC prerequisite tree." Journal of Engineering Design **14**(3).
- Marneffe, M., B. Maccartney, et al. (2006). Generating Typed Dependency Parses from Phrase Structure Parses. Proceedings of LREC-06.
- Miles, F. D., Ed. (1972). Technique of Value Analysis and Engineering, McGraw-Hill Book Company.
- Modarres, M. and S. W. Cheon (1999). "Function-centered modeling of engineering systems using the goal tree-success tree technique and functional primitives." Reliability Engineering & System Safety **64**(2): 181-200.
- Montecchi, T. and D. Russo (2011). FBOS: Function/Behaviour-Oriented Search. ETRIA Conference TRIZ Future, TFC, Dublin, Ireland.
- Montecchi T., Russo D., et al. (2013). "A New Concept IPC Searching Tool: Comparison between Keywords and Concept-based Search." Submitted to Journal Advanced Engineering Informatics.
- Newell, A. and H. A. Simon (1972). Human problem solving, NJ: Prentice Hall.
- Pahl, G. and W. Beitz (1977). Konstruktionslehre, Springer.
- Petrov, V. (2003). History of Standards System Evolution. Information materials. Tel-Aviv.
- Rodenacker, W., Ed. (1971). Methodisches Konstruieren, Springer.
- Ruppenhofer, J., M. Ellsworth, et al. (2010). FrameNet II: Extended Theory and Practice.
- Russo, D. and V. Birolini (2011). "Towards the right formulation of a technical problem." Procedia Engineering **9**(0): 77-91.
- Russo, D. and T. Montecchi (2011). Creativity Techniques for a Computer Aided Inventing System. ICED11, International Conference on Engineering Design, Copenhagen, Denmark.
- Russo, D. and T. Montecchi (2011). A Function-Behaviour Oriented search for patent digging. ASME 2011, International Design Engineering Technical Conferences & Computers and Information in Engineering Conference, Washington, DC, USA.

- Russo, D. and T. Montecchi (2012). Functional-based search for patent technology transfer. ASME 2012, International Design Engineering Technical Conferences & Computers and Information in Engineering Conference, Chicago, Illinois.
- Russo, D., D. Regazzoni, et al. (2011). "Methodological enhancements for concept exploration in product design." Int. J. Product Development **15**(Nos. 1/2/3): 28.
- Salamatov, Y., Ed. (1999). TRIZ: The right solution at the right time, Insytec B.V.
- Santorini, B. (1990). Part-of-speech tagging guidelines for the Penn Treebank Project. Technical report MS-CIS-90-47, Department of Computer and Information Science, University of Pennsylvania.
- Savransky, S. D., Ed. (2000). Engineering of Creativity: Introduction to Triz Methodology of Inventive Problem Solving, CRC Press.
- Souchkov V. (2005). Root Conflict Analysis (RCA+): Structuring and Visualization of Contradictions. ETRIA Conference TRIZ Future Graz, Austria.
- Terninko, J., A. Zusman, et al., Eds. (1998). Systematic Innovation : An Introduction to TRIZ (Theory of Inventive Problem Solving), CRC Press.
- Terninko, J., A. Zusman, et al. (1998). Systematic innovation: An introduction to TRIZ;(theory of inventive problem solving), CRC.
- Toutanova, K., D. Klein, et al. (2003). Feature-Rich Part-of-Speech Tagging with a Cyclic Dependency Network. HLT-NAACL 2003.
- Umeda, Y., H. Takeda, et al., Eds. (1984). Function, Behaviour, and Structure. AIENG '90, Applications of AI in Eng., Computational Mechanics Publications and Springer Verlag.
- Umeda, Y. and T. Tomiyama (1995). "FBS Modeling: Modeling Scheme of Function for Conceptual Design." Workshop on Qualitative Reasoning about Phys.'Systems: 271-278.
- Verhaegen, P. A., J. D'hondt, et al. (2011). "Searching for similar products through patent analysis." Procedia Engineering **9**(0): 431-441.
- Vermaas, P. and K. Dorst (2007). "On the conceptual framework of John Gero's FBS-model and the prescriptive aims of design methodology." Design Studies **28**(2): 133-157.
- Zanni-Merk, C., D. Cavallucci, et al. (2009). "An ontological basis for computer aided innovation." Computers in Industry **60**(8): 563-574.

zlotin. "Innovation Workbench." from

<http://www.ideationtriz.com/new/iwb.asp>.

Zlotin, B. and A. Zusman (1999). ARIZ on the Move, TRIZ Journal, Ideation International Inc., March, www.triz-journal.com/archives/1999/03/e/index.htm.

Zlotin, B. and A. Zusman (2005). Theoretical and Practical Aspects of Development of TRIZ-based Software Systems. ETRIA Conference TRIZ Future 2005, Graz.