



UNIVERSITY OF PADOVA

DOCTORATE SCHOOL OF CROP SCIENCE
CURRICULUM AGROBIOTECHNOLOGY - CYCLE XXI
Department of Agricultural Biotechnology

***AN APPARENTLY USELESS CONSERVED GENE IN
Rhizobium sllae***

Director of the school: Ch. mo Prof. Andrea Battisti

Supervisor: Ch. mo Prof. Sergio Casella

PhD student: Mariangela Bottegal

THESIS SUBMISSION DATE

February 2nd, 2009

Declaration

I hereby declare that this submission is my own work and that, to the best of my knowledge and belief, it contains no material previously published or written by another person nor material which to a substantial extent has been accepted for the award of any other degree or diploma of the university or other institute of higher learning, except where due acknowledgment has been made in the text.

January 31st, 2009

Mariangela Bottegal

A copy of the thesis will be available at <http://paduaresearch.cab.unipd.it/>

To Angela

Index

Index	vii
Riassunto	1
Summary	5
Introduction	9
The biogeochemical nitrogen cycle	9
The denitrification process	11
Proteins of denitrification	12
Respiratory nitrate reductases	14
Nitrite reductase	15
Copper-Nitrite Reductase	15
General properties and structure of copper- nitrite reductase	16
Nitric oxide reductase	18
Nitrous oxide reductase	19
Biochemistry and molecular biology of denitrification	19
Genetic basis of denitrification	20
Bacterial diversity in denitrification	22
Rhizobia	23
Brief outline of the infection process in plants and root nodules formation	24
Denitrification in bacteria of <i>Rhizobiales</i> order	27
Rhizobium sllae symbiont of Hedysarum coronarium	28
The truncated denitrification chain in <i>Rhizobium sllae</i> strain HCNT1	30
VBNC state in <i>Rhizobium sllae</i>	32
Recent acquisitions	35
Selenium	36
Selenium in cellular metabolism	37
Methylation	38
<i>Rhizobium sllae</i> and the reduction of selenite	39
Materials and methods	41
Bacterial strains and growth conditions	41
Conservation of bacterial strains	41

Plate growth with selenite	43
Growth of bacterial strains in liquid culture with selenite	43
Reduction of selenite under different incubation conditions.....	43
The induction of <i>nirK</i> activity in <i>Rhizobium sullae</i> strains.....	44
Nitrite Reductase Assay	44
Preparation of cell-free extracts.....	45
β -Galactosidase assay.....	45
Determination of protein content.....	46
Gas-chromatograph analysis	46
Agarose gel electrophoresis.....	47
Isolation of genomic DNA from <i>R. sullae</i> strain HCNT1	47
PCR amplification of <i>nirK</i> fragment and <i>nirK</i> CDS	47
Purification of DNA fragments from agarose gel and sequencing.....	48
RNA extraction and cDNA synthesis.....	48
Primer design for CDS amplification of <i>nirK</i> gene.....	49
Plasmid and strain construction.....	51
Preparation of electro-competent <i>E. coli</i> JM109 cells.....	53
Preparation of competent <i>E. coli</i> M15 cells	53
Isolation of DNA plasmid of <i>E. coli</i>	54
Transformation of <i>E. coli</i> strain JM109	54
Transformation of <i>E. coli</i> strain M15	55
Bacterial expression of 6xHis-tagged recombinant protein	55
Polyacrylamide gel electrophoresis in the presence of SDS (SDS-PAGE).....	55
Time-course analyses of protein expression.....	56
Determination of target protein solubility	56
<i>E. coli</i> culture growth for preparative purification.....	57
Preparation of cleared <i>E. coli</i> lysates under denaturing conditions.....	57
Batch purification of 6xHis-tagged proteins from <i>E. coli</i> under denaturing conditions .	57
Refolding of purified Nir protein	58
Results and discussion	59
Growth of <i>Rhizobium sullae</i> in presence of selenite	59

Growth of <i>Rhizobium sllae</i> in liquid culture with selenite	61
Selenite reduction under different incubation conditions	65
Evaluation of the constitutive selenite reductase activity in <i>Rhizobium sllae</i>	66
Effect of diethyldithiocarbamate (DDC) on selenite reduction activity	68
Regulation of <i>nirK</i> gene.....	69
mRNA extraction and cDNA synthesis	70
Evaluation of nitrous oxide production	71
Effect of diethyldithiocarbamate (DDC) on nitric oxide production.....	72
Selenium deposits	73
Choice of a suitable expression system for protein purification.....	74
Construction of the expression plasmid for Nir protein production	75
Time-course analyses of protein expression	77
Determination of target protein solubility	79
Overproduction and batch purification of Nir protein	82
<i>In vitro</i> assay for nitrite and selenite reduction activity.....	83
Conclusions	87
Acknowledgements	91
References	93
Appendix	111
General acknowledgements	121

Riassunto

Rhizobium sullae, un batterio azotofissatore, induce la formazione di noduli radicali in *Hedysarum coronarium* L., una leguminosa foraggiera conosciuta in Italia con il nome di sulla e spontanea in quasi tutto il bacino del Mediterraneo, considerato il suo areale d'origine.

Sebbene la capacità di denitrificare possa essere utile alla sopravvivenza e alla crescita delle cellule batteriche in ambienti anossici, il processo di denitrificazione tra i rizobi è piuttosto raro. Soltanto *B. japonicum* e *A. caulinodans* si comportano come i veri denitrificanti, riducendo il nitrato (NO_3^-) simultaneamente a NH_4^+ (assimilazione) e N_2 (denitrificazione), quando fatti crescere, in condizioni di microaerofilia, in colture contenenti nitrato come sola fonte di azoto. *R. sullae* strain HCNT1 ha dimostrato di possedere una nitrito riduttasi contenente rame (Cu-Nir), in grado di produrre ossido nitrico (NO) e codificata dal gene *nirK*, mentre non possiede invece l'ossido nitrico riduttasi e gli altri enzimi richiesti per il processo completo di denitrificazione.

L'espressione del gene *nirK* è atipica e unica nel suo genere, poiché non richiede la presenza del suo substrato, il nitrito (NO_2^-), ma soltanto di una diminuzione della concentrazione di ossigeno in una fase di induzione. La riduzione del nitrito da parte del ceppo HCNT1 provoca l'inibizione della crescita cellulare, a causa dell'accumulo di NO a livelli tossici per la cellula microbica, a conferma che *R. sullae* non contiene l'enzima Nor (ossido nitrico reduttasi). Il processo di nodulazione, la crescita della pianta ospite e la capacità azoto-fissatrice del ceppo wild-type sono del tutto simili a quelle riscontrate nei ceppi mutanti *nirK*.

L'esistenza di un ruolo fisiologico per la catena di denitrificazione interrotta riscontrata in *R. sullae* non ha in realtà una spiegazione ovvia. È possibile che l'attività dell'enzima Nir permetta alle cellule batteriche di convertirsi nella forma VBNC (viable-but-not-culturable), in modo tale che possano sopravvivere in condizioni di stress anche per lunghi periodi, senza perdere tuttavia la capacità di riprendere lo stato vegetativo.

Recentemente il ceppo HCNT1 ha dimostrato di possedere la capacità di crescere in presenza di alte concentrazioni di selenito (50 mM); inoltre, durante la crescita, il selenito è stato ridotto a selenio elementare non tossico e di colore rosso.

Un ceppo mutante di HCNT1, HCAT2, privo del gene per la nitrito riduttasi, non ha mostrato tuttavia la stessa capacità del wild-type di ridurre il selenito, non essendo in grado di crescere in mezzi colturali contenenti selenito 25 o 50 mM, o avendo scarsa capacità di crescere anche in presenza di basse concentrazioni di selenito (5 mM).

Un altro ceppo di *R. sultae*, denominato A4, è stato isolato dallo stesso suolo dove in precedenza era stato isolato il ceppo HCNT1. Il ceppo A4 ha mostrato un comportamento molto simile a HCNT1 per quanto riguarda la risposta alla presenza del selenito nel mezzo di coltura, mentre il mutante A4 *nirK* un comportamento più simile a quello del ceppo HCAT2. La mancanza del gene *nirK* sembra quindi rendere i ceppi molto più sensibili alla presenza dell'ossianione del selenio.

A confermare questa evidenza, un ceppo wild-type privo del gene *nirK*, *R. sultae* CC1335, isolato in un ambiente diverso da quello di HCNT1 e A4, ha mostrato la sua incapacità di crescere in presenza di selenito. D'altra parte, il trasferimento del gene *nirK* di HCNT1 nel ceppo CC1335 ha contribuito ad incrementare la sua resistenza a questo ossianione.

I dati raccolti in questi esperimenti hanno suggerito, quindi, la possibilità che la nitrito riduttasi di *R. sultae* possa far parte di un meccanismo responsabile della resistenza al selenito, indicando una spiegazione plausibile per l'esistenza della catena di denitrificazione radicalmente troncata e riscontrata unicamente in questo batterio.

Tenendo presente la capacità di Nir di ridurre differenti ossianioni oltre al nitrito, come ad esempio il selenito, è stato proposto per questo enzima un meccanismo di multifunzionamento, ovvero la proteina Nir potrebbe agire da nitrito o da selenito riduttasi in base al substrato e alle condizioni aerobiche o anaerobiche in cui si trova il microorganismo.

Al fine di supportare quest'ultima ipotesi, sono state valutate le possibili correlazioni esistenti tra i sistemi di riduzione dei due ossianioni.

In particolare è stato dimostrato che la riduzione del selenito avviene sia in condizioni aerobiche che anaerobiche, e che si tratta di una attività enzimatica costitutiva, a differenza dell'attività nitrito riduttasica, la quale richiede un periodo di induzione in condizioni limitanti di ossigeno. È stato riscontrato, inoltre, che l'aggiunta di nitrito in una coltura già contenente selenito non interferisce con la riduzione di quest'ultimo ossianione alla forma elementare del selenio. Al contrario, l'aggiunta di selenito a colture già contenenti nitrito ha

mostrato di inibire la produzione degli ossidi di azoto, nei casi in cui venga aggiunto prima, durante o dopo la fase di incubazione in microaerofilia.

L'utilizzo di uno specifico chelante delle nitrito reduttasi contenenti rame (Cu-Nir) insieme al selenito contenuto nel un mezzo colturale, ha rivelato che l'enzima responsabile della riduzione del selenito in *R. sultae* contiene rame, poiché l'attività selenito reduttasica viene inibita e non vi è formazione del colore rosso.

Si è dunque reso necessario procedere alla purificazione della proteina al fine di studiarne più in dettaglio le proprietà. Ciò ha comportato la ricerca di una strategia adeguata che facesse uso di un sistema biologico appropriato. *E. coli*, generalmente utilizzato a questo scopo, ha mostrato di possedere vie metaboliche che portano alla riduzione del selenito a selenio elementare. Al fine di procedere in maniera inequivocabile alla produzione e purificazione della proteina è stato quindi necessario ricorrere alla costruzione di una proteina ricombinante marcata con istidina (6xHis) per l'espressione in *E. coli*, per poter poi procedere alla purificazione per affinità. Ciò ha comportato un ritardo imprevisto sulla tabella di marcia delle attività di dottorato. Tuttavia la proteina Nir è stata infine purificata e sono stati condotti saggi *in vitro* per testarne l'effettiva capacità di ridurre il nitrito e il selenito separatamente. In tal modo è possibile chiarire se la nitrito e la selenito reduttasi sono la stessa proteina che lavora in modo diverso a seconda del substrato e delle condizioni in cui si trovano le cellule batteriche, o se si tratta di due proteine distinte che lavorano indipendentemente. L'approccio preliminare che è stato possibile attuare su una prima frazione di proteina purificata ha indicato che le condizioni di espressione e il metodo di purificazione possono avere una grande influenza sull'espressione stessa. Mentre la riduzione del nitrito è stato già verificata con successo, occorreranno tempi un po' più lunghi per ottenere discrete quantità dell'enzima da utilizzare in tutte le potenziali condizioni di espressione.

Summary

Rhizobium sullae, a nitrogen fixing symbiotic bacterium, induces nodules formation on *Hedysarum coronarium* L.

Although the ability to denitrify may enhance bacterial survival and growth capability in anaerobic soils, denitrification among rhizobia is rare, and only *B. japonicum* and *A. caulinodans* have been shown to be true denitrifiers, reducing nitrate (NO_3^-) simultaneously to both NH_4^+ (assimilation) and N_2 (denitrification), when cultured microaerobically with nitrate as the only nitrogen source. *R. sullae* strain HCNT1 has been shown to have a copper-containing nitrite reductase (Nir), producing nitric oxide (NO), encoded by a *nirK* gene, but not a complementary nitric oxide reductase and the other enzymes required for a complete denitrification pathway.

Expression of *nirK* is atypical in that it does not require the presence of a nitrogen oxide, but only a decrease in oxygen concentration. Reduction of nitrite (NO_2^-) by strain HCNT1 results in the inhibition of growth due to the accumulation of NO to toxic levels, suggesting that *R. sullae* does not contain any Nor (nitric-oxide reductase). Nodulation, plant growth and rates of N_2 fixation are similar between wild-type and *nirK*-deficient strains.

The physiological role of the truncated denitrification chain found in *R. sullae* is not obvious. It is possible that Nir activity allows the bacteria to convert into a VBNC form, which would survive for long periods under stress conditions without loss of the ability to recover the vegetative state.

Recently strain HCNT1 was found to be able to grow in the presence of high concentration of selenite (50 mM); moreover, during the growth, selenite was reduced to less toxic elemental red selenium, as indicated by the appearance of red colour in the culture. A mutant strain of HCNT1, HCAT2, lacking nitrite reductase, showed no evidence of selenite reduction, grew poorly in the presence of 5 mM of selenite and was unable to grow in the presence of higher concentrations (25 or 50 mM). Other strains, like A4, isolated from the same site where HCNT1 was originally collected, showed a similar behaviour of HCNT1, while its *nirK* mutant, a became similar to HCAT2. Once again, the loss of *nirK* gene seemed to make strains much more sensitive to selenite.

Furthermore, a naturally occurring nitrite reductase deficient *R. sultae*, strain CC1335, isolated from a quite different site, was found unable to grow in the presence of selenite. Mobilization of *nirK* gene of HCNT1 into CC1335 increased its resistance to this oxyanions.

These data have suggested that nitrite reductase of *R. sultae* could provide resistance to selenite indicating a possible explanation for the radically truncated denitrification chain, found uniquely in this bacterium.

On the basis that Nir was able to reduce different oxyanions in addition to nitrite, such as selenite, it has been proposed a multifunction mechanism for nitrite reductase. In order to support this hypothesis, any possible correlation between nitrite and selenite reduction was evaluated. It was demonstrated that selenite reduction occurs either in aerobic or in anaerobic condition and that it is a constitutive enzymatic activity, unlike nitrite reduction activity that requires the induction after a period of incubation under limiting oxygen conditions. Moreover, the addition of nitrite in the culture containing selenite did not prevent the reduction of this oxyanion to elemental selenium form. On the other hand, the presence of selenite in cultures containing nitrite prevented the production of nitric oxide, either if it was added before or at the end of the induction phase.

The enzyme responsible of selenite reduction has shown to contain copper, since it responds exactly like the known Cu-nitrite reductase to the addition of a specific chelator (DDC) , that completely inhibited selenite reduction and the consequent appearance of the red colour.

Therefore, protein purification became critical in order to better understand its properties. This activity requires a suitable strategy and an appropriate biological system. *E. coli*, generally used for this purposes, showed to possess different metabolic pathways leading to reduce selenite to elemental selenium. In order to unambiguously proceed to the production and purification of Nir, the construction of a recombinant protein polyhistidine-tagged (6xHis) for the expression in *E. coli* and the subsequent affinity purification, was carried out. This produced a unexpected delay for the last experiments. However, Nir protein has been purified and some tests for nitrite and selenite reduction activities were performed with the aim to clarify if the two enzymes are the same protein working in a different way, depending upon the substrate and the general conditions adopted. The preliminary approach

on a first fraction of the purified protein indicated that the conditions required for its expression and possibly the purification method adopted, can consistently affect the expression of the protein as nitrite or selenite reductase. While the reduction of nitrite has been successfully verified, medium-long periods of time are required to obtain the right amount of the purified enzyme to be used in all the possible expression conditions.

Introduction

The biogeochemical nitrogen cycle

All living cells require combined nitrogen for the synthesis of many key biomolecules. The assimilation of nitrogen occurs via incorporation of ammonium. However, nitrogen is present in many oxidation states in nitrate (+5), nitrite (+3), nitric oxide (+2), nitrous oxide (+1), dinitrogen (0) and ammonium (-3). The nitrogen cycle involves several redox processes, which ensure a balanced recycling of the nitrogen compounds (Figure 1).

In the reductive assimilatory process, nitrate is reduced to ammonium which is incorporated into central metabolism through the combined action of glutamine synthetase and glutamate synthase or through glutamate dehydrogenase. The reductive dissimilatory processes involve the conversion of nitrate (NO_3^-) into nitrite (NO_2^-) (respiration) or into ammonia (NH_4^+). Both respiration and ammonification are energy conserving processes and can be used as an electron sink. The oxidation of ammonium to nitrate is achieved by the sequential activities of ammonia oxidizing bacteria, which oxidize ammonia to nitrite, and nitrite oxidizing bacteria, which oxidize nitrite to nitrate. Taken together these processes are known as nitrification. Ammonia and nitrite oxidizers have an important role in the conversion of nitrogenous compounds in their natural environment (e.g. soils, sediments and lakes) and in wastewater treatment systems. Although the process is known to take place in an aerobic environment, recently the anaerobic oxidation of ammonia has been described. This process, carried out by some members of the Planctomycetes like *Brocadia anamoxidans*, is called anammox (anoxic ammonia oxidation). The oxidation of ammonium is coupled to the reduction of nitrite, and yields a molecular dinitrogen and free energy for maintenance and growth. The biochemistry of anammox is still under investigation, but nitrite appears to be an electron acceptor, and hydrazine an intermediate (Strous *et al.*, 1999; van de Graaf *et al.*, 1995). The anammox is of great ecological importance and allows the removal of ammonium from anaerobic sites in natural environments and in wastewater treatment plants.

The fixation of atmospheric nitrogen is in part achieved by chemical reaction of dinitrogen and oxygen induced by lightning, which gives rise to nitric oxide (NO). In the oxygen-rich

atmosphere, nitric oxide is then oxidized to nitrogen dioxide and taken up in the oceans in the form of nitrate ions. Biological nitrogen fixation into ammonium as carried out by certain bacteria, however, is much more efficient and makes most of the nitrogen available to living cells.

Finally, the cycle is closed by a microbiological process called denitrification, bringing nitrogen back to the atmosphere in the N_2 molecular form.

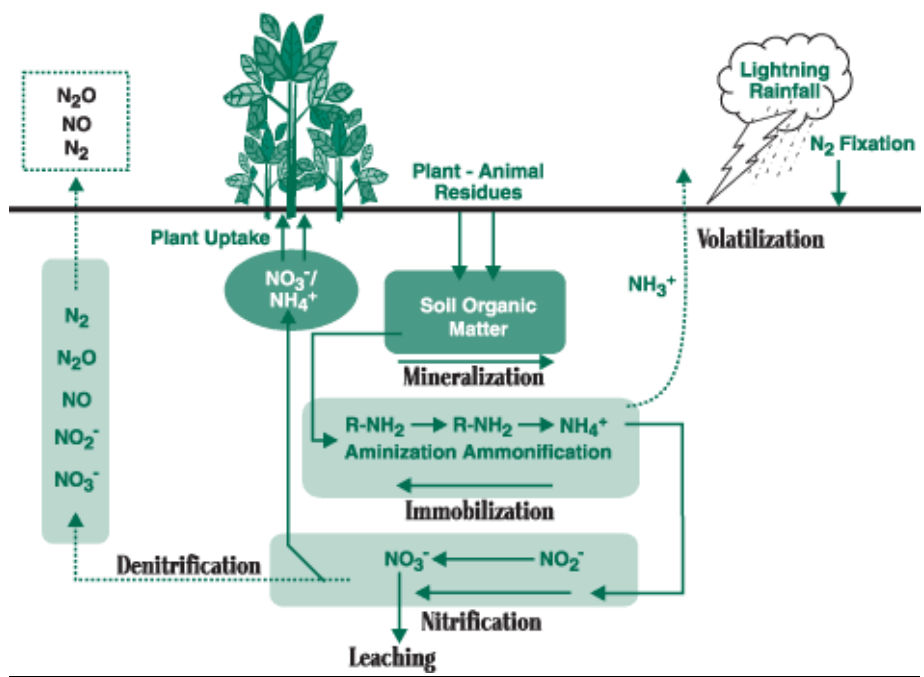
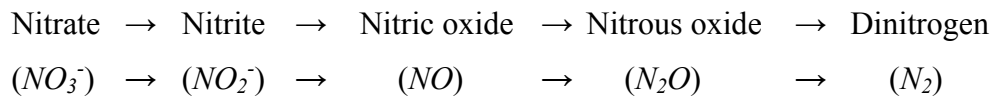

Figure 1 – Biogeochemical cycle of nitrogen.

The denitrification process

The specific cause of nitrogen removal from soil and water is an anaerobic bacterial process called *denitrification*, the reduction of nitrate or nitrite to N₂ and to a small amount of N₂O (Ingraham, 1981; Payne, 1981), (Figure 2). As part of the global nitrogen cycle, denitrification pathway is responsible for the return of fixed nitrogen back to the atmosphere and is of great importance for sustainable life on Earth. From agricultural perspective, this process makes a limit to the amount of nitrogen accessible to plants and counters the efforts aimed at maximizing the productions. From the standpoint of bioremediation of pollutants, however, denitrification reactions detoxify combined nitrogen run-off and wastewaters contaminated with excess of nitrogen compounds (Margaret *et al.*, 2006). Denitrification is an energy-yielding process in which microorganism utilize nitrate and all the other intermediate nitrogen oxides as terminal respiratory electron acceptor under oxygen limiting conditions. The overall reaction sequence, where nitrate is reduced via nitrite to gaseous products, is the following:



Denitrification is clearly an anaerobic respiration. For many years it was believed to be performed exclusively by eubacteria. However, there are indications that some fungi (e.g. the pathogenic species *Fusarium oxysporum*) and archaea are also able to denitrify.

Bacteria of many different systematic groups can perform denitrification. However, some microorganism can reduce nitrate only to nitrite and others only to nitrous oxide.

Products of denitrification have manifold, mainly adverse, effects on the atmosphere, soils and waters and thus have both agronomic and environmental impact. When nitrate is converted to gaseous nitrogen by denitrifying bacteria in agricultural soils, nitrogen is lost as an essential nutrient for the growth of plants. In contrast to ammonium, which is tightly bound in soil, nitrate is easily washed out and flows to the groundwater where it (and its reduction product nitrite) adversely affects water quality. In addition, nitrogenous oxides released from soils and waters are in part responsible for the depletion of the ozone layer above the Antarctic, and in part for the initiation of acid rain and global warming. Thus the

impact of products of denitrification, both in soils, waters and the atmosphere is of extreme relevance for human welfare and makes a detailed knowledge of this process essential.

Denitrification is primarily a bacterial respiratory process and consists of four enzymatic reaction steps, catalysed by four metalloproteins: nitrate reductase, nitrite reductase, nitric-oxide reductase and nitrous oxide reductase. Denitrifiers are microorganisms using nitrogen oxides in place of oxygen and thus respiring under anaerobic conditions. Nitrogen and small amounts of nitrous oxide are released into Earth's atmosphere, closing the cycle that begins with fixation.

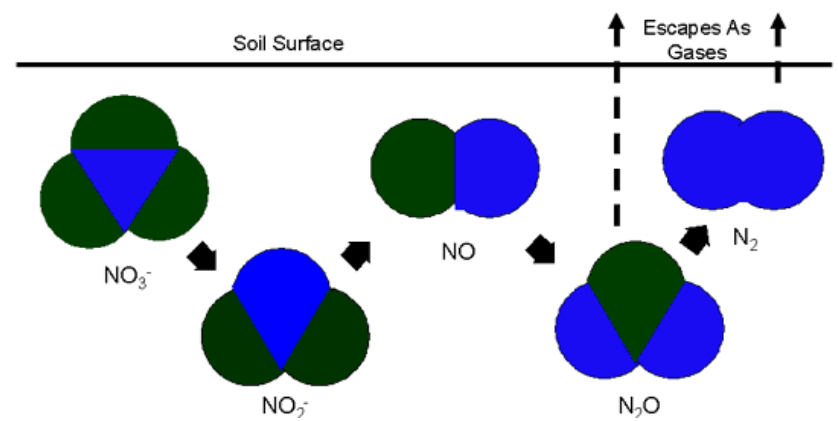

Figure 2 – Scheme of denitrification in soil.

Proteins of denitrification

In general, the proteins required for denitrification are only produced under anaerobic conditions, and if anaerobically grown cells are exposed to O_2 then the activities of the proteins are inhibited. Thus, for denitrifying organisms, respiration of O_2 usually occurs in preference to the use of N-oxides or oxyanions.

In all bacteria the enzymes of denitrification receive e^- from the respiratory chain system that is part of the cytoplasmic membrane (Figure 3). In other words, denitrification is a form of respiration and shares respiratory chain components with the e^- transport system

that delivers e^- to O_2 via terminal oxidases (Nicholls and Ferguson, 2002; Baker *et al.*, 1998).

Electrons are delivered to cytochrome cd_1 by a mono-heme c -type cytochrome c_{550} , or a cupredoxin protein called pseudoazurin. These two periplasmic and water-soluble proteins are reduced by an integral membrane complex called the cytochrome bc_1 complex, which in turn is reduced by ubiquinol. This complex is not specific for denitrification; it occurs in diverse respiratory chain systems in bacteria as well as in the mitochondrial e^- -transfer chain.

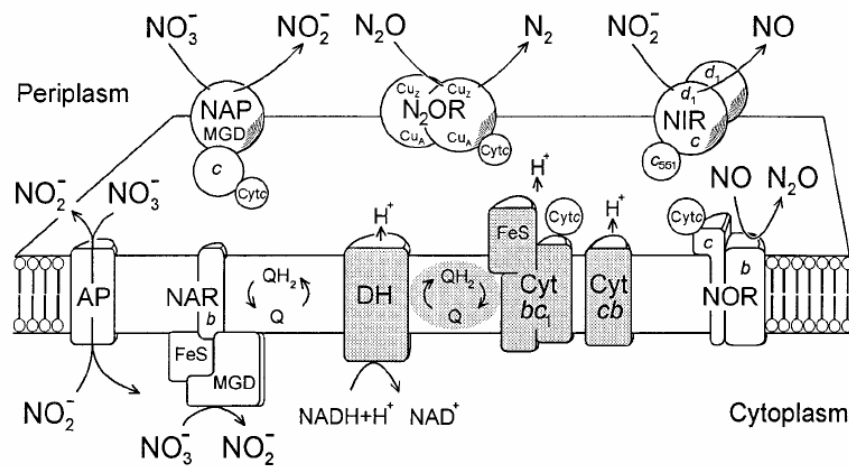

Figure 3 – Organization and sidedness of the anaerobic electron transfer chain of *P. stutzeri*. The shaded areas represent the components of the constitutive aerobic respiratory chain consisting of a NADH dehydrogenase complex (DH), quinone cycle (Q, QH_2), cytochrome bc_1 complex (Cyt bc_1), and the cytochrome cb terminal oxidase complex (Cyt cb). The denitrification system comprises respiratory nitrate reductase (NAR), nitrite reductase (NIR), NO reductase (NOR), and N_2O reductase (N_2OR). Evidence for the existence of the periplasmic nitrate reductases (NAP) in *P. stutzeri* is derived from DNA hybridization; the enzyme is modeled according to the situation with *R. eutropha* and *Paracoccus denitrificans*. Abbreviations: FeS, iron-sulfur centers; b , c , and d_1 , heme B, heme C, and heme D1, respectively; cyt c , unspecified c -type cytochromes accepting electrons from the bc_1 complex and acting on N_2OR and NOR; cyt c_{551} , cytochrome c_{551} ; AP, postulated nitrate/nitrite antiporter.

Respiratory nitrate reductases

The first reaction, the conversion of nitrate to nitrite, is catalysed by a Mo-containing nitrate reductase. Two types of dissimilatory nitrate reductases have been found in denitrifying bacteria. One is known as the respiratory membrane-bound nitrate reductase (Nar), and the other is the periplasmic nitrate reductase (Nap) (Moreno-Vivian and Ferguson, 1998; Moreno-Vivian *et al.*, 1999; Richardson and Watmough, 1999; Richardson *et al.*, 2001; Potter *et al.*, 2001). Membrane-bound nitrate reductase (Nar enzyme) employs a redox loop to couple quinol oxidation with proton translocation and energy conservation, which permits cell growth under oxygen limiting conditions. Periplasmic nitrate reductase (Nap enzyme) also oxidizes quinol, but this enzyme is thought to participate indirectly in nitrate respiration by functioning in an electron-transport chain with a proton-translocating enzyme, such as NADH dehydrogenase I (Berks *et al.*, 1995; Moreno-Vivian and Ferguson, 1998; Richardson, 2000).

Most of biochemical and genetic studies have been focussing on *E. coli* and *Paracoccus* Nar enzymes. Nar is a 3-subunit enzyme composed of NarGHI. NarG, the alpha-subunit of about 140 kDa, contains the bis-MGD molybdopterin cofactor at its catalytic site and a [4Fe-4S] cluster. NarH, the beta-subunit of about 60 kDa contains four additional iron-sulphur centres: one [3Fe-4S] and three [4Fe-4S]. NarG and NarH are located in the cytoplasm and associate with NarI, the gamma subunit. NarI is an integral membrane protein of about 25kDa with 5 transmembrane helices and the N-terminus facing the periplasm. Nar proteins are encoded by genes of a *narGHJI* operon. The organization of this operon is conserved in most species that express Nar. The *narGHI* genes encode the structural subunits, and *narJ* encodes a dedicated chaperone required for the proper maturation and membrane insertion of Nar. *E. coli* has a functional duplicate of the *narGHJI* operon, *narZYWW*. The subunits of the two enzymes are interexchangeable.

Nap is widespread in all classes of denitrifying and non-denitrifying proteobacteria but has not yet been found in other phyla of the bacterial superkingdom (Richardson, 2000). The best-studied Nap enzymes were isolated from *Paracoccus denitrificans* (Sears *et al.*, 1995), *Paracoccus pantotrophus* (Bell *et al.*, 1993; Berks *et al.*, 1994), *E. coli* (Grove *et al.*, 1996),

Rhodobacter sphaeroides (Richardson *et al.*, 1990), *Ralstonia eutropha* (Siddiqui *et al.*, 1993) and *Pseudomonas putida* (Carter *et al.*, 1995). Nap is a 3 subunit enzyme composed of NaoABC. The NapAB complex is located in the periplasm and associates with a transmembrane NapC component.

Nitrite reductase

The next step in the denitrification pathway is the reduction of nitrite to nitric oxide catalysed by nitrite reductase. There are two type of respiratory nitrite reductase characterized in denitrifying bacteria, a homodimeric enzyme with heme *c* and *d*₁ (NirS, *cd*₁- type; 120 kDa in its dimeric form), and a homotrimeric enzyme with copper atoms (NirK, copper-type; 3 x 36 kDa). Both are periplasmic proteins and receive electrons from cytochrome *c* and/or a blue copper protein, pseudoazurin (Koutny *et al.*, 1999; Moir and Ferguson, 1994). Neither of the enzymes is electrogenic since both take up the electrons and protons required for nitrite reduction at the same side of the membrane, i.e. the periplasm.

NirK and NirS are never found together in a single species. All denitrifiers characterized so far have only one of these two types of nitrite reductases, that seem to be mutually exclusive, but both are present in distinct species of the genera *Pseudomonas* and *Alcaligenes*. The structural and functional characteristics of both enzymes have recently been reviewed (Cutruzzolà, 1999; Watmough *et al.*, 1999). In contrast to the complex organisation of the genes encoding the *cd*₁-type Nir, e.g. *nirSTBMCFDLGH* in *Pseudomonas stutzeri*, a single gene, *nirK*, is responsible for the synthesis of Cu-Nir in other denitrifiers.

Copper-Nitrite Reductase

Nitrite reductase (Nir) is a key enzyme in the dissimilatory denitrification chain, catalyzing the reduction of NO₂⁻ to NO (Zumft, 1997). Although this has been a matter of debate for a

long time, NO is now accepted as a product of NO₂⁻ reduction and an obligatory intermediate in most denitrifiers; it is further reduced to N₂O by NO reductase.

Purification and characterization of Nir from several bacterial sources have shown that there are two distinct classes of dissimilatory Nirs that yield NO as the main reaction product, containing either copper (CuNir) or heme (*cd*₁Nir) as cofactor; the heme-containing enzyme occurs more frequently. Although the most studied denitrifying strains contain heme nitrite reductases, the copper nitrite reductases are present in a greater number of genera. The nitrite reductases can be distinguished easily by their inhibition pattern: the CuNir is inhibited by copper chelating agent diethyldithiocarbamate (DDC), by cyanide and by carbon monoxide, whereas *cd*₁ nitrite reductase is inhibited by cyanide but not by carbon monoxide (Tavares *et al.*, 2006). Functional complementation of a *cd*₁Nir-deficient strain of *Pseudomonas stutzeri* with the CuNir from *Pseudomonas aureofaciens* indicates that the two enzyme fulfil the same role in vivo.

General properties and structure of copper- nitrite reductase

Copper-containing nitrite reductase (CuNir) (E.C. 1.7.99.3) is present both in Gram-negative and Gram-positive (*Bacillus sp.*) eubacteria and in Archea (*Haloarcula sp.*). The CuNir class is more heterogeneous than the *cd*₁Nir one in terms of molecular properties, although the primary structure is well conserved within each subclass, ranging from 60% to 80% protein identity in different species. The proteins are synthesized as longer precursors, with a leader peptide responsible for the periplasmic transport.

Common features are trimeric quaternary structure in which a monomer (~ 40 kDa) contains two distinct Cu-centres, one belonging to the type I Cu subclass and the other being a type II Cu. The only exception, known to date, was found in *Hyphomicrobium denitrificans* A3151 (HdNir) (Yamaguchi *et al.*, 2004), where the CuNir is composed of six identical subunits.

Spectroscopic and site-directed mutagenesis studies on the two Cu-centres showed that the type I site is the redox active site from which the electrons necessary for catalysis are transferred to the type II site, where substrate binding occurs.

The primary product of CuNir is NO; however the enzyme can also yield a small amount (3-6%) of N₂O if NO accumulates. Other reactions such as the conversion of NO₂⁻ to NH₄⁺ or reduction of O₂ have also been described, although at much lower rates.

The total number of Cu atoms found in enzymes from different sources may differ considerably from the ideal six, depending on purification and storage, but six Cu atoms have been found in all crystal structure determined to date.

The overall architecture of this enzyme is organized as a homotrimer where the three identical subunits are tightly associated around a central channel of 5-6 Å in a threefold axis symmetry (Figure 4). Each monomer is composed of two distinct domains, each consisting of a Greek key β-barrel fold similar to that of cupredoxins (Adman, 1991; Adman *et al.*, 1995). An extensive network of H-bonds, both within and between the subunits of the trimer, confers considerable rigidity to the molecule. The protein conformation does not experience large shifts in atoms position neither at different pH values nor in the different redox- or ligand-bound states. In three-dimensional structure of CuNir purified from *A. cycloclastes* it was shown for the first time that the type I Cu sites (two His, one Cys and one Met ligands) are located within each monomer, while the type II sites are at the interface between monomers in the trimer, with ligands (three His and one solvent molecule) provided by two different subunits (Strange *et al.*, 1995).

The two Cu sites are linked via a His-Cys bridge with a Cu-Cu distance of 12.,5-13 Å. The type II Cu is not essential for subunit stability; consistently, only minor structural changes are observed in the type II Cu-depleted enzyme from *A. cycloclastes*.

According to the spectroscopic properties of the type I Cu, these proteins can be classified as blue and green CuNirs. The blue CuNirs from *A. xylosoxidans* share a 593 nm absorption band caused by the charge-transfer transition of type I Cu (S_(Cys)→ Cu²⁺), which confer an EPR signal of this metal centre with axial symmetry. The green CuNirs (*A. cycloclastes* and *A. faecalis*) show two bands at 460 nm and 584 nm also due to a S_(Cys)→ Cu²⁺ transfer transition of type I Cu but with a rhombic EPR signal (Dodd *et al.*, 1997; Kukimoto *et al.*, 1994).

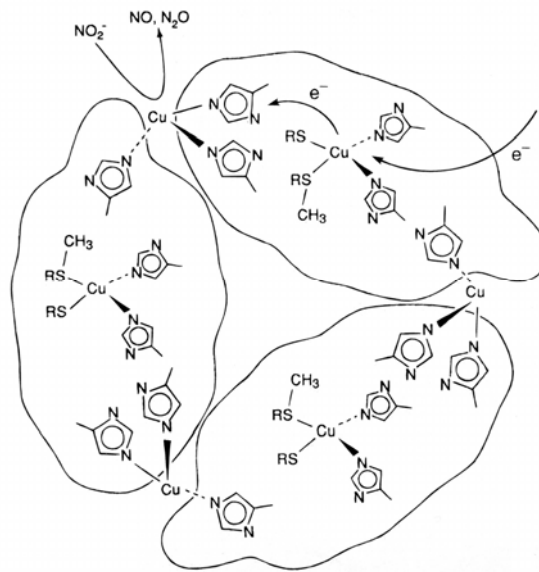

Figure 4 – Cu-containing nitrite reductase from *A. cycloclastes*. Schematic representation of the trimer and position of Cu atoms. The six Cu atoms are coordinated by cysteine, histidine, and methionine. The type 2 Cu is bound by three histidines between the subunit interfaces.

Nitric oxide reductase

Since nitric oxide is toxic and highly reactive, it is effectively utilized by Nor making sure that the free oxide-concentration in denitrifying organisms is kept in nanomolar range. Two type of Nor enzymes have been identified in denitrifying species; one type that receives electrons from cytochrome *c* or pseudoazurin, referred to as cNor, and another type that receives electrons from quinol, referred so as qNor (Zumft, 1997; Wautmouth, 1999; Hendriks *et al.*, 2000). Both types are structurally related integral membrane proteins, which catalyse the two-electron reduction of two nitric oxide molecules to nitrous oxide. Nitric oxide reductase of the cNor-type is a membrane bound enzyme which contain two subunits, a small one (17 kDa) containing heme *c* and a large one (53k Da) with heme *b* and a non-heme iron. The qNor-type nitric oxide reductase is encoded by a single *norB* gene, has 14 putative transmembrane helices and has been purified from *Ralstonia*

eutropha where it has been shown that it consists of a subunit of 75 kDa containing both high-spin and low-spin haem *b* and a ferric non-haem iron (Cramm *et al.*, 1997)

Nitrous oxide reductase

The last step in denitrification is the two-electron reduction of nitrous oxide to dinitrogen gas. This reaction is carried out by a nitrous oxide reductase (Nos), which is a homodimeric soluble protein located in periplasmic space. The enzyme has been purified from a large number of denitrifying strains, including *Paracoccus denitrificans* (Snyder and Hollocher, 1987), *P. pantotrophus* (Berck *et al.*, 1993) and *Pseudomonas Stutzeri* (Coyle *et al.*, 1985). Nos is a homodimer of a 65 kDa copper-containing subunit that binds a mixed valence dinuclear Cu_A electron entry site and tetra-nuclear Cu_Z catalytic centre. Each monomer is made up of two domains the “Cu_A domain” that has a cupredoxin fold and “Cu_Z domain”, which is a seven-bladed propeller of beta-sheets. Electron input into Cu_A is usually via mono-haem *c*-type cytochromes or cupredoxins. The enzyme was first isolated from *P. stutzeri* and the corresponding structural gene was designated *nosZ*. Additional genes required for associated regulatory and electron transfer components, and information for metal processing and protein assembly or maturation are encoded by the *nosRZDFYLtatE* operon (Honisch and Zumft, 2003).

Biochemistry and molecular biology of denitrification

The denitrification part of the N-cycle transforms nitrate (NO₃⁻) into N₂ gas. This is a reductive process and thus is a form of respiration that generates an H⁺-motive force across the cytoplasmic membrane of the cell. An important parameter is the number of net positive charge that are moved outwards from the cytoplasm to the periplasm for each pair of e⁻ moving from an ubiquinol to a terminal e⁻-acceptor. The organization of the Nar NO₃⁻ -reductase means that net of H⁺-translocation occurs with a stoichiometry of 2H⁺/2e⁻. The periplasmic NO₂⁻ and N₂O -reductases cannot themselves be involved in H⁺-movement across the membrane. Although, e⁻ transfer from ubiquinol to NO₂⁻, NO or N₂O is coupled

to H^+ -translocation across the membrane because this is catalyzed by the cytochrome *bc*₁ complex. The effective translocation stoichiometry is $2H^+/2e^-$, i.e. the same for the NO_3^- -reductase reaction. Periplasmic H^+ consumption does not have any implication for the net charge moved across the membrane; the H^+ consumption is accompanied by equal e^- -uptake by the periplasmic reductases and so there is no change to the net charge translocation into the periplasm. Oxygen is usually the preferred e^- -acceptor for denitrifying bacteria but the exact biochemical mechanism that ensure preferential e^- -flow to O_2 is not known. Although the steady state H^+ -motive force is likely to be similar of magnitude during aerobic respiration and denitrification, the H^+ -translocation stoichiometry per $2e^-$ will be higher by approximately 40% when O_2 is the e^- -acceptor. This means that the APT yield per $2e^-$ flowing to a terminal acceptor from any given reductant available to the cells will be higher for aerobic respiration, thus explain why denitrifying bacteria prefer aerobic growth conditions.

This preference for O_2 over NO_3^- , NO_2^- , NO and N_2O is also reflected in the regulation of expression of denitrification-specific genes.

Denitrification occurs in four stages, NO_3^- to nitrite (NO_2^-), NO_2^- to nitric oxide (N_2O) and N_2O to N_2 . All steps within this metabolic pathway are catalysed by complex multisite metalloenzymes with characteristic spectroscopic and structural features (Berks *et al.*, 1995). In recent years, high-resolution crystal structures have become available for these enzymes with the exception of the structure for NO -reductase (Einsle and Kroneck, 2004).

Genetic basis of denitrification

Access to denitrification genes was first sought by conjugational and transductional mapping in *Pseudomonas aeruginosa*. An important outcome of the early genetic analysis was the finding that *P. aeruginosa* encodes the respiratory (*nar*) and the assimilatory (*nas*) nitrate reductase systems from distinct gene sets (Sias *et al.*, 1980). This was also shown for *Ralstonia eutropha* (formerly *Alcaligenes eutrophus*) (Warnecke-Eberz and Friedrich, 1993) and the nitrate respirer *Klebsiella pneumoniae* (Lin *et al.*, 1994; Wientjes *et al.*, 1979) and is assumed to be the rule for nitrate-assimilating denitrifiers. The distinct genetic basis for the respiratory and assimilatory process manifests itself in regulatory responses.

Genes for nitrate assimilation are repressed by ammonia and do not respond to oxygen, while the expression of *nar* genes occurs at low oxygen concentrations and does not respond to ammonia. Oxygen inhibits nitrate uptake for nitrate respiration of denitrifiers or nitrate respirers (Hernandez and Rowe, 1988) but has no effect on nitrate assimilation.

The subunits of membrane-bound NO_3^- -reductase (Nar) are encoded by genes of a *narGHJI* operon. The organization of this operon is conserved in most species that express Nar. The *narGHI* genes encode the structural subunits, and *narJ* encodes a dedicated chaperone required for the proper maturation and membrane insertion of Nar. In many species, a *narK* gene encoding a $\text{NO}_3^-/\text{NO}_2^-$ transporter precedes the *narGHJI* genes. A set of *narXL* genes encoding a two-component regulatory system, which modulates the expression of Nar in response to $\text{NO}_3^-/\text{NO}_2^-$ concentration, is found upstream of the *nar* gene cluster from denitrifying *Pseudomonas*. The α -proteobacteria have the *narXL* genes replaced by an *fnr*-like gene encoding an FNR homologue designated NarR. This protein is a transcriptional regulator that modulates the expression of the *nar* operon most likely in response to the intracellular NO_3^- or NO_2^- concentration.

Most of the operons that encode the subunits of periplasmic NO_3^- -reductase (Nap) comprise the *napABCD* genes. The *napABC* genes encode the structural subunits, and *napD* has a likely role as chaperone in the correct assemblage of Nap. In addition to *napABCD*, *nap* operons may include one or more of *napKEFGH* genes, but their occurrence and position in the operons differ in species. The NapFG proteins might constitute an alternative e^- -transfer pathway to this type of NO_3^- -reductase. It is evident that the distinction in *nap* operon organization does not show a phylogenetic pattern of the species in which they are found; this is suggestive of lateral transfer of the *nap* operons.

The gene encoding the structural monomers of cd_1 -type NO_2^- -reductase, *nirS*, makes part of a *nir* gene cluster. The number and organization of *nir* genes in these cluster differ in different species. However, they share a number of genes that are proposed to encode a multimeric and multifunctional enzyme complex involved in the maturation and insertion of a specific heme d_1 into NO_2^- -reductase.

The Cu-type NO_2^- -reductase is encoded by the *nirK* gene. In some species, the *nirK* genes clusters with a downstream-located *nirV* gene, encoding a protein of unknown function.

The minimum genetic potential to express NO-reductase (Nor) appears to be a *norCBQD* operon, where *norCB* genes encode the structural subunits I and II. The NorQ and NorD proteins are essential for activation of Nor. Some more specialized denitrifiers have additional *norEF* genes, the products of which are involved in maturation and/or stability of Nor activity.

The *nos* gene clusters encoding N₂O-reductase (Nos) are highly conserved in denitrifiers and consist of at least seven genes located in the same transcriptional direction and in the order *nosRZDFYLX*. The *nosZ* gene encodes the N₂O-reductase protein. The *nosDFYL* genes encode proteins that are apparently required for Cu assemblage into Nos, although their specific role remains to be established. The NosRX proteins have roles in transcription regulation, activation and Cu assemblage of Nos.

Bacterial diversity in denitrification

Bacteria with the capability of denitrification belong to a broad variety of groups and encompass a wide range of physiological traits. Denitrifiers are somewhat more frequent within the alpha and beta classes of the *Proteobacteria*, although there is no recognizable pattern of distribution. Denitrification is notably absent from enterobacteria which respire nitrate to nitrite and direct the further reduction of nitrite to ammonification. Hyperthermophily (Huber *et al.*, 1992; Völkl *et al.*, 1993) and the attitude to tolerate alkalinity (Berendes *et al.*, 1996) are also traits recognized among the denitrifying prokaryotes.

Most denitrifiers are aerobic heterotrophic organisms that transfer redox equivalents from the oxidation of a carbon source to an N oxide under anaerobic conditions. Autotrophic denitrifiers utilize inorganic sulfur compounds, hydrogen, ammonia or nitrite. It was found that oxidation of Fe (II) is also coupled to a complete denitrification process: $10\text{FeCO}_3 + 2\text{NO}_3^- + 24\text{H}_2\text{O} \rightarrow 10\text{Fe}(\text{OH})_3 + \text{N}_2 + 10\text{HCO}_3^- + 8\text{H}^+$ (Straub *et al.*, 1996). The reaction is carried out by established denitrifiers as well as by new Gram-negative isolates awaiting classification. Among the carboxidotrophic bacteria, only *Pseudomonas carboxydohydrogena* grows autotrophically under denitrifying conditions with H₂ as the

electron donor and CO₂ as the carbon source (Frunzke and Meyer, 1990; Meyer *et al.*, 1990).

The oxidation of CO is not coupled to denitrifying growth; *Pseudomonas carboxydoflava* expresses the complete denitrification pathway but is sensitive to CO in the reduction of N₂O.

P. carboxydohydrogena, *Zavarzinia* (formerly *Pseudomonas*) *compransoris*, and *Pseudomonas gazotropha* all terminate denitrification with N₂O. Denitrification and ammonification has been described for “*Pseudomonas putrefaciens*” (Samuelsson, 1985), a species that belongs to the *Shewanella* branch (De Vos *et al.*, 1989).

Among the diazotrophic bacteria, denitrification was detected in *Azospirillum* (formerly *Spirillum*) *lipoferum* (Danneberg *et al.*, 1986), *A. brasilense* Sp7 (Danneberg *et al.*, 1989), and the microaerophilic *Magnetospirillum magnetotacticum* (Bazylnski and Blakemore, 1983). *Bradyrhizobium japonicum* and a considerable number of other rhizobia are able to denitrify (O’Hara and Daniel, 1985). *Azoarcus tolulyticus* is a diazotrophic toluene-degrading bacterium which exhibits complete denitrification (Zhou *et al.*, 1995); *A. evansii* degrades a variety of monoaromatic compounds under denitrifying conditions but is unable to use toluene (Anders *et al.*, 1995).

Denitrification and diazotrophy can proceed concomitantly. The end product of the former process was shown to be carried out to nitrogen fixation (Dunstan *et al.*, 1982). Among the Pseudomonads, diazotrophic strains have been reported for *P. fluorescens*, *P. putida* (not a denitrifier), and *P. stutzeri* (Chan *et al.*, 1994).

Diazotrophic denitrifiers are also found among the phototrophic bacteria. The first isolate of a photosynthetic denitrifying bacterium, *Rhodobacter sphaeroides* f. sp. *denitrificans* IL106 (Sato *et al.*, 1976), is a regular strain of *R. sphaeroides* because of the 16S rRNA similarity (Hiraishi and Ueda, 1994).

Rhizobia

The genus *Rhizobium* of the class α - *Proteobacteria*, order *Rhizobiales*, and family *Rhizobiace*, comprises approximately twenty species of heterotrophic, Gram-negative, non-spore forming, rod shape, aerobic bacteria. Within the genus are free-living members as

well as species that are capable of forming plant hypertrophies, either as symbiotic nitrogen-fixing nodules, or as pathogenic tumors (Young *et al.*, 2001; Young *et al.*, 2003). Symbiotic members of the genus carry pSym plasmid with *nod* and *nif* genes that enable them to form nitrogen-fixing root nodules. Nodulation is a multi-step process that involves specific plant and bacterial gene expression. The process starts with multiplication of bacteria in the rhizosphere, followed by chemotaxis to plant exudates, adhesion of rhizobia to the root and infection. The initiation of this infection process requires the mutual exchange of molecular signals between the bacterium and host plant. Many symbiotic rhizobia develop these nodules in association with important agricultural crops (beans, alfalfa, clover, peas, etc.), and the nitrogen fixed by these nodule forming bacteria, symbiotic diazotrophs, has greatly benefited humankind. It is estimated that symbiotic rhizobia, in association with cultivated legumes, fix 40 to 60 million tones of nitrogen yearly (Smil, 1999), greatly decreasing the need that these and the succeeding agricultural crops have for nitrogen fertilizer.

Members of genus *Rhizobium* also show considerable resistance to selenium and tellurite oxyanions (Hamdi, 1968; Kinkle *et al.*, 1994). Their resistance to these heavy metals likely comes from their ability to reduce the soluble toxic oxyanions of these metals to elemental forms that are insoluble and therefore not biologically available (Hunter and Kuykendall, 2007; Trutko *et al.*, 2000; White *et al.*, 1997). Thus, some members of this group of bacteria may have future value as a tool for removing heavy metals from contaminated soils and water.

Brief outline of the infection process in plants and root nodules formation

In order to initiate a productive symbiosis, rhizobia must recognize and then respond to the presence of host plant roots. During growth in the rhizosphere of a host plant, rhizobia sense compounds such as flavonoids and betaines secreted by the host root and respond by inducing *nod* genes (Cassab, 1998; Cosgrove *et al.*, 1997; Cosgrove *et al.*, 2002). The *nod* genes encode approximately 25 proteins required for the bacterial synthesis and export of Nod factor. Nod factor is a lipooligosaccharide signal consisting of a chitin backbone, four

to five *N*-acetylglucosamine units in length, with a lipid attached to the nonreducing end and host-specific modifications on the backbone (Figure 5). Nod factor initiates many of the developmental changes seen in the host plant early in the nodulation process, including root hair deformation, membrane depolarization, intracellular calcium oscillations, and the initiation of cell division in the root cortex, which establishes a meristem and nodule primordium. Other responses of rhizobia upon encountering a host root undoubtedly involve changes in the expression of genes other than those involved in Nod factor synthesis. Such genes are likely to be important for rhizobia to compete effectively with other organisms for access to growth substrates emanating from the host root, to adhere to the root surface, and to become resistant to toxic substances such as phytoalexins secreted by the root. Early during symbiosis, rhizobia must get from the root surface to the inner root tissue where they will populate cells in the incipient nodule. To do this, they grow and divide inside a tubule called an infection thread. Infection thread formation is most often initiated when rhizobia become trapped between two root hair cell walls. This usually occurs when a deformed root hair forms a sharp bend or curl, and bacteria bound to the root hair become trapped between appressed cell walls (Callaham and Torrey, 1981). Invagination of plant cell wall in the curl, or degradation of the wall and invagination of the cell membrane, followed by tip growth of the invagination results in the initiation of an infection thread that grows down the inside of the root hair and into the body of the epidermal cell. Rhizobia inside the thread grow and divide, thereby keeping the tubule filled with bacteria. If the infection thread exits the epidermal cell, it does so by fusing with the distal cell wall, and bacteria enter the intercellular space between the epidermal cell and the underlying cell layer. Invagination and tip growth, similar to those seen at the beginning of infection thread growth, occur in the underlying cell, and a thread filled with bacteria is propagated further toward the root interior (Van den Bosch *et al.*, 1989; van Spronsen *et al.*, 1994; van Workum *et al.*, 1998). Branching of the thread as it grows through the root and enters the nodule primordium increases the number of sites from which bacteria can exit the thread and enter nodule cells, ensuring that a sufficient number of nodule cells are colonized. Bacteria inside the infection thread eventually exit it and enter nodule cells. Once inside nodule cells, the bacteria continue to differentiate and synthesize proteins required for nitrogen fixation and for the maintenance of the mutualistic partnership.

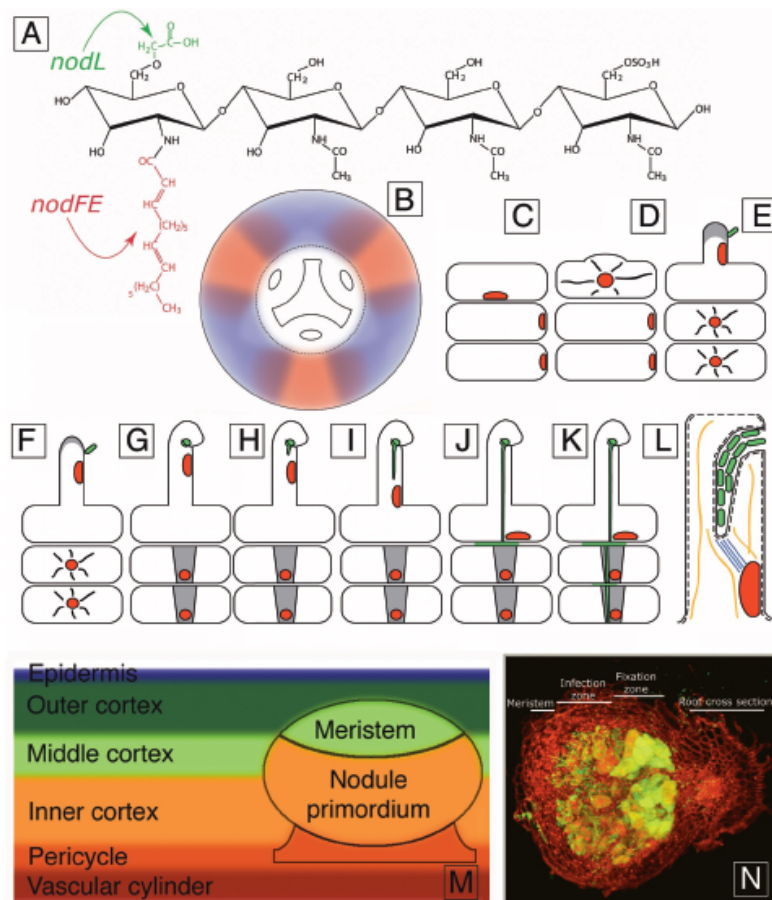

Figure 5 - Overview of the nodulation process in plants that form indeterminate nodules. (A) One form of Nod factor synthesized by *S. meliloti*. The green arrow indicates the acetyl group added by NodL, and the red arrow indicates the lipid moiety, the length and degree of saturation of which is modified by NodF and NodE. (B) Diagrammatic cross section of a root, showing gradients of an activating factor at protoxylem poles (blue) and an inhibitor at protophloem poles (red). Together such gradients may determine which root cells can become activated in response to infecting rhizobia. Nodules are typically formed next to the protoxylem poles, which are at the ends of the Y-shaped structure depicted in the center the diagram, rather than above the protophloem poles, which are depicted as ovals. (C) An epidermal cell and two underlying outer cortical cells. The epidermal cell has a nucleus positioned across from the place where a new root hair will form. (D) Root hair initiation in the epidermal cell. (E) Binding of a rhizobial cell to a type I root hair and activation of the underlying cortical cells in response to Nod factor. (F) Continued growth of the root hair, shown as stage II. (G) Curling of the stage II root hair under the influence of Nod factor and growth of a rhizobial microcolony in the curl. The underlying cortical cells have become polarized, and cytoplasmic bridges (PITs) have formed and are shown in grey. (H) Infection thread initiation. (I) Growth of the infection thread down the root hair. The nucleus moves down the root hair in front of the thread. (J) Fusion of the infection thread with the epidermal cell wall and growth of

rhizobia into the intracellular space between the epidermal cell and the underlying cortical cell. (K) Growth of the infection thread through PITs in the outer cortical cells. (L) Enlarged view of the root hair shown in panel I. The curl has been unrolled to show that topologically, the bacteria in the infection thread are still outside the root hair. The plant cell wall and plant cell membrane are shown as black and dashed lines, respectively. Microtubules are located between the nucleus and the infection thread tip (blue). Actin cables are depicted as orange strands. These are likely to be found where indicated in the diagram because cytoplasmic streaming is seen in these areas during the progression of infection threads down root hairs. Bacteria are topologically outside the root until they later bud from the tip of the thread and enter nodule cells as membrane-enclosed bacteria. (M) Diagram showing root tissues and a young nodule not yet emerged from the root. The derivation of nodule tissues from root tissues is indicated. (N) A longitudinal section of 10-day-old alfalfa nodule. The nodule was infected with GFP-expressing *S. meliloti*, and the infection thread network can be seen behind the meristem region of the nodule. The initial infection site that gave rise to the bacteria in the nodule can be seen on the nodule periphery at the left. Propidium iodide (red) was used to counterstain the plant tissue. The root from which the nodule emerged is seen in cross-section at the right (Gage, 2004).

Denitrification in bacteria of *Rhizobiales* order

In recent years it has emerged that many rhizobia species have genes for enzymes for some or for all the four reductases for denitrification. This process can be readily observed in many rhizobia species, in their free-living form, in legume root nodules, or as isolated bacteroids (O'Hara *et al.*, 1985). The ability to denitrify is much more widespread in the bacterial world than is the ability to nitrify. Denitrifying bacteria are found in all the major branches of the tree of life. Although the activity to denitrify may enhance bacterial survival and growth capability in anaerobic soils, denitrification among rhizobia is rare, and only *Bradyrhizobium japonicum* and *Azorhizobium caulinodans* have been shown to be true denitrifiers, this is, to reduce nitrate simultaneously both to ammonia (assimilation) and nitrogen (denitrification) when cultured microaerobically with nitrate as not only the terminal electron acceptor but also the sole source of nitrogen. Other soil microorganism have been shown to possess higher rates of denitrification activity than rhizobia (Garcia-Plazaola *et al.*, 1993), but the vast area all over the world of cultivated legumes makes contribution of rhizobia to total denitrification highly significant.

In order to study the molecular biology of denitrification, it is important to focus on the genes that encode the enzymes, located in the cytoplasmic membrane or in the periplasm, that are responsible for the nitrogen respiration reactions. The complete reduction of nitrate

to nitrogen gas requires four terminal reductases: nitrate reductase, nitrite reductase, nitric oxide reductase and nitrous oxide reductase (Zumft, 1997). Structural genes encoding each of these reductases have been identified from a number of denitrifiers. Most species among rhizobia do not contain the whole set of denitrification gene (Table 1). *Rhizobium sllae* (formerly *Rhizobium "hedisary"*) only expresses a copper containing nitrite reductase, encoded by *nirK* gene (Toffanin *et al.*, 1996).

Table 1 - Denitrification genes in nitrogen-fixing endosymbiotic rhizobia.

Species	Genes	Energy conservation	Reference
<i>Rhizobium sllae</i>	<i>nirK</i>	-	Toffanin <i>et al.</i> 1996
<i>Sinorhizobium meliloti</i>	<i>napEFDABC</i> , <i>nirK</i> , <i>norCBQD</i> , <i>nosRZDFYLX</i>	-	Holloway <i>et al.</i> 1996 Chang <i>et al.</i> 1997 Genome sequence
<i>Rhizobium etli</i>	<i>nirK</i> , <i>norCBQD</i>	-	Girard <i>et al.</i> unpubl.
<i>Bradirhizobium japonicum</i>	<i>napEDABC</i> , <i>nirK</i> , <i>norCBQD</i> , <i>nosRZDFYLX</i>	+	Mesa <i>et al.</i> 2001 Velasco <i>et al.</i> 2002 Delgado <i>et al.</i> 2003 Velasco <i>et al.</i> 2004

Rhizobium sllae symbiont of Hedysarum coronarium

Rhizobium sllae, formerly "*Rhizobium hedysari*" (Squartini *et al.*, 2002) , induces nodule formation on *Hedysarum coronarium* L., French honeysuckle (Figure 6). This vegetable species, belongs to *Rosales* order, *Papillionaceae* family, *Hedysareae* tribe. The genus *Hedysarum* includes about 100 species distributed in Europe, Africa, Asia and North America. The species *H. coronarium* L. are spontaneous in almost all the Mediterranean basin, which is considered its native area.

French honeysuckle represents one of the most important species of forage plants cultivation in Mediterranean environments. This legume is tolerant to several stress factors

including drought, salinity and alkaline soil (pH up to 9.6) so resulting well-adaptable to marginal areas, deserts and basic clays. The plant also appears well suited to grow in soils containing low amounts of phosphorus. The quality of its forage and a rapid productivity have made sulla a popular agronomic crop in Spain and Italy.

Bacteria isolated from the nitrogen-fixing root nodules of sulla have been described and studied by different authors. A peculiar strain of *R. sullae*, HCNT1, has been shown to contain a Cu-containing Nir encoded by *nirK* gene. The expression of this gene is atypical as it does not required the presence of a nitrogen oxide, but only a decrease in oxygen concentration (Casella *et al.*, 1986). Reduction of NO_2^- by strain HCNT1 results in inhibition of growth due to the accumulation of nitric oxide (NO) to toxic levels, suggesting that *R. sullae* does not contain any Nor (Casella *et al.*, 1986).

Nodulation, plant growth, and rates of N_2 - fixation are similar between wild-type and *nirK* deficient strain. *R. sullae* strain HCNT1 has been shown to enter a viable-but-non culturable status when O_2 is limiting, and NirK produces NO from nitrite present in growth medium (Toffanin *et al.*, 2000). A physiological role for the truncated denitrification chain in *R. sullae* is not obvious. It is possible that Nir activity allows to convert the bacteria into a viable-but non culturable form, which, in turn, would make the strain surviving for long periods of time under stress conditions without losing the ability to recover the vegetative state (Casella *et al.*, 2006).



Figure 6 - French honeysuckle (*Hedysarum coronarium* L.).

The truncated denitrification chain in *Rhizobium sllae* strain HCNT1

While in many species of rhizobia, called real denitrifiers, the denitrification process normally runs from nitrate to nitrogen gas, in many bacterial species it is possible to observe an incomplete pathway (Zumft, 1992; Zumft and Körner, 1997). In this case, the microorganisms stop their activities to intermediate stages, reducing only partially NO_2^- and NO_3^- ions. The incomplete denitrification frequently produces nitrous oxide as the final product. A considerable number of studies have described the lack of enzymes able to reduce nitrous oxide to nitrogen gas in several bacteria such as *Chromobacterium violaceum*, *Pseudomonas aurofaciens* and many rhizobia species (Zumft, 1992). A number of studies have indicated the peculiarity of *Rhizobium sllae* strain HCNT1, a nitrogen fixing bacterium that induces symbiotic nodule formation on the legume *Hedysarum coronarium* (Casella *et al.*, 1984; Squartini *et al.*, 1993; Struffi *et al.*, 1998; Squartini *et al.*, 2002). In this strain the fragmentation of denitrification pathway has been studied and a radical truncation of its electron transport chain was described. The strain only contains a nitrite reductase that reduces nitrite (NO_2^-) to nitric oxide (NO), encoded by *nirK* gene, closely related to nitrite reductase of true denitrifying bacteria.

The unusual and unique expression of *nirK* gene in *R. sllae* strain HCNT1 has been underlined (Casella *et al.*, 1986): it does not require the presence of its substrate, NO_2^- , but depends exclusively by the decrease in oxygen concentration (less than 16.5% of air saturation). The reduction of nitrite determines the stop of HCNT1 growth; this inhibition is most likely due to NO accumulation to toxic levels (Toffanin *et al.*, 1996).

NO is a lipophilic radical able to spread through the cellular membrane and the cytoplasm. The nitric oxide has a negative influence on the metabolism of microbial cells, by acting as inhibitor of many metalloproteins, such as the cytochrome oxidases (Brown, 1995). Further NO cellular targets are the thiols (Muckopadhyay *et al.*, 2004), glutathione and omocystein (Storz and Hengee-Aronis, 2000; Poole, 2005).

The nitric oxide, as well as an intermediate product of denitrification, is also a crucial molecule signal in several biological systems (Zumft *et al.*, 1988): at concentrations of about 10^{-7} M, NO controls blood pressure in mammals and acts as a messenger in the central and peripheral nervous system.

To directly assess whether the reduction of nitrite in *R. sultae* results in the accumulation of NO to toxic levels, a modified electrode sensitive to NO was used to track nitrite reductase products in HCNT1 strain and its mutant, HCAT2, obtained from the wild type by inactivation of *nirK* gene. In wild type strain, the electrode detected significant concentrations of NO, about 15 μ M. In HCAT2, as expected, NO production was not found (Toffanin *et al.*, 1996).

The inactivation of *nirK* gene, obtained in HCAT2 strain, eliminates the negative consequences deriving from NO accumulation, without producing any further phenotypic changes.

Strain HCNT1 has not NO reduction activities. Nitric oxide levels achieved in HCNT1 could be caused, consequently, by the lack of nitric oxide reductase. In the true denitrifying bacteria, in fact, the reduction of nitric oxide allows to keep it at nanomolar concentrations (Goretski and Hollocher, 1988).

The results of PCR analysis, using specific primers to detect the presence of *norB* gene, have confirmed this hypothesis (Basaglia *et al.*, 2004).

Moreover, in strain HCNT1 there is not even nitrate reduction activity since, adding NO_3^- in cultural medium, there is not anaerobic growth and the inhibition of oxygen uptake does not occur.

Therefore, *R. sultae* HCNT1 can be considered an unusual rhizobium, characterized by a radical truncation in the electron transport chain, showing only one of the four terminal reductases requested for the complete pathway of denitrification. While the evolutionary advantage deriving from the complete denitrification pathway may be easily explained, the advantage gained from expressing only a fragment of this pathway has not been completely clarified.

The HCNT1 strain can be defined an atypical and unique diazotroph among denitrifying rhizobia species.

The most important competitive advantage is the ability of true denitrifiers to survive, in free living forms, even in the absence of oxygen, by nitrate and nitrite anaerobic respiration.

This assumption is not reflected in the strain HCNT1 unable to grow as true denitrifiers. During the reduction of nitrite to nitric oxide does not occur any proton translocation.

If we consider, moreover, that Nir activity, in the presence of nitrite, inhibits aerobic respiration, since its product (NO) binds to the terminal oxidases, the reduction of nitrite also prevents other pathways that allow the microbial cells to preserve energy. Once all the available nitrite has been reduced, oxygen consumption may resume.

Under anaerobic condition there is no cellular growth in the presence of nitrite as a final electron acceptor. At low concentration of oxygen, bacterial cells result significantly sensitive to nitrite: micromolar concentrations of NO_2^- prevent cellular growth and inhibit aerobic respiration, both in bacteroids and in free living cells (Casella *et al.*, 1988).

In conclusion, there are no valid elements able to demonstrate any bioenergetic benefits deriving from nitrite reduction. A hypothesis recently investigated suggested that the presence and the expression of nitrite-reductase could be a strategy to decrease the cell energetic content, inducing a condition of deep dormancy (Toffanin *et al.*, 2000; Casella *et al.*, 2001). Some evidences seem to connect *nirK* activity to viability and culturability of *R. sultae* cells (Basaglia *et al.*, 2007). During intranodular life its role could be the protection of nitrogenase .

Strains of the same species, that lack *nirK* gene, such as strain CC1335, are able to form nodules and fix atmospheric nitrogen at comparable levels with HCNT1 (Casella *et al.*, 1984). Up to now, in many analyzed conditions no differences between wild type and *nirK* deficient strains were found, in terms of efficiency of nodulation, growth of plants and nitrogen-fixation.

However, these considerations require further analysis and evaluations, since this strain seems to gradually lose its ability to nodulate under laboratory conditions.

VBNC state in *Rhizobium sultae*

One advantage that could be expected from the possession of Nir enzyme is that free-living HCNT1 can conserve energy via the respiration of nitrite. However, no obvious bioenergetic benefit was detected as a consequence of nitrite respiration because HCNT1 could not grow under low oxygen condition in nitrite-containing medium (Casella *et al.*, 1986).

The presence and the expression of nitrite reductase could be a strategy during intranodular life to protect nitrogenase and leghaemoglobin. However, given that a more toxic compound is produced when the nitrite is reduced, the nitrite detoxification hypothesis seems unlikely (Basaglia *et al.*, 2004). Some evidences seem to establish a connection between Nir activity and viability and culturability of HCNT1 cells. Comparison of nodulation efficiency, plant growth and nitrogen fixation have not revealed any significant differences between wild type and nitrite reductase-deficient strain of HCNT1. It has also been observed that naturally occurring strains of *Rhizobium sllae* that lack Nir, such as strain CC1335, can nodulate and fix nitrogen at the same level as HCNT1 (Casella *et al.*, 1984). Recent studies have also investigated whether nitrite reductase activity is used as a strategy to reduce the energy content in the bacterial cells in order to induce dormancy (Toffanin *et al.*, 2000; Casella *et al.*, 2001, Casella *et al.*, 2006).

Several bacterial species, such as *Vibrio vulnificus*, *Sinorhizobium meliloti*, *Micrococcus luteus*, *Escherichia coli* and *Helicobacter pylori* (McDougald *et al.*, 1998), in reply to many stress factors (high or low temperature, lack of nutrients, such as N and C, osmotic shock, radiations, salinity), enter the viable-but -not-culturable state (VBNC).

In this particular metabolic state, bacteria lose their capacity to growth on cultural media, that generally represent the nutrient sources, and undergo morphological and physiological alterations. Microorganisms in VBNC state, in fact, increase very much their resistance to different chemical and physical factors, increase their tolerance to sonication and, usually, are characterized by a deep alteration in the membrane and cell wall structure (Weichart and Kjelleberg, 1996). Moreover, lipid and protein content of the cells also undergo modifications (Linder and Oliver, 1989, McGovern and Oliver, 1995; Mukamolova *et al.*, 1995). A lot of gram-negative bacteria can enter the VBNC state (Oliver, 1993; Oliver *et al.*, 1995) and the interpretation of this peculiar physiological state is, up to now, a matter of debates. Some authors consider VBNC microorganisms as dying cells (Bogossian *et al.*, 1987), someone else believe VBNC state as a survival strategy, carried out by microbe when environmental conditions are particularly unfavourable (Roszak and Colwell, 1987; Oliver, 1993). In HCNT1 strain, unlike the most part of rhizobia, the entrance to VBNC state takes place with an oxygen limiting content, but also when nitrite ion is present and Nir is expressed, producing consequently nitric oxide (Toffanin *et al.*, 2000).

The use of a specific fluorescent dyes, such as Syto 9, CTC (5-cyano-2,3-di-4-tolyl-tetrazolium-chloride), acridine orange and propidium iodide has made possible a more accurate evaluation of the viability and the metabolic state of microbes (Basaglia *et al.*, 1997).

Experiments performed with *S. meliloti* 41, a rhizobium nodulating *Medicago sativa*, showed that it enters VBNC status in liquid microcosms when O₂ is depleted from the atmosphere of the incubation mixture (Toffanin *et al.*, 2000; Casella *et al.*, 2001). It was possible to transform *S. meliloti* 41 with a plasmid carrying luciferase gene (*luc*), a reporter gene, obtaining *S. meliloti* 41 pRP4-*luc*. This strain and the parental strain were used as a model system for VBNC experiments, both *in vitro* and also in soil samples and in the plant system. This strain has been found to recover its viability under certain conditions, only at a given ratio to the number of metabolically active cells (Casella *et al.*, 2001). *R. sultae* strain HCNT1 enters the same VBNC status when oxygen is limiting, but only when nitrite is present and Nir is expressed allowing for the production of NO (Toffanin *et al.*, 2000). The hypothesis that expression of *nirK* by HCNT1 may induce the VBNC status has been investigated through a comparison of *S. meliloti* and *R. sultae*. It was found that nitrite reductase activity may reduce energy content but it was unclear whether this was an indirect consequence of the production of nitric oxide or a required result that would prolong cell viability under certain conditions. While the energy content of *S. meliloti* decreased under anoxic conditions, leading the strain to the VBNC status, HCNT1 only reduced its internal energy under anoxic conditions when nitrite was present. NO does not accumulate at lethal levels, because differential staining of the cells during oxygen uptake experiments in the presence of nitrite revealed that they are still alive, although the CFU (colony forming units) number had dramatically decreased (Toffanin *et al.*, 2000). An explanation of this result is that NO produced by nitrite reduction induced VBNC status, making the cells more stress-resistant. This metabolic state confers to the cells the ability to tolerate stresses, including anoxic conditions, antibiotic effects or nutrient depletion. When suitable environmental conditions reoccur, it has been demonstrated that some VBNC bacterial populations, including *S. meliloti*, can recover their culturability (Casella *et al.*, 2001).

To better understand the role of Nir protein in *R. sultae*, the VBNC status in CC1335 strain, which does not possess *nirK* gene, was examined. Prolonged incubation of CC1335 under anaerobic conditions resulted in a significant decrease of CFU, even if the use of two nucleic acid-binding stains, SYTO9 and propidium iodide (LIVE/DEAD *BacLight*[®] bacterial viability kit) indicates that the cells are still alive. Therefore, unlike HCNT1, CC1335 can enter VBNC without Nir activity, but only in absence of oxygen. In order to support the hypothesis that the expression of *nirK* is favourable because it induces the VBNC status, *nirK* from HCNT1 was mobilized into CC1335, a strain of *R. sultae* that lacks *nirK*, and the resulting phenotype was studied. The presence of *nirK* in CC1335 strain results, under anoxic incubation, a phenotype similar to that of HCNT1: there is no anaerobic growth, but the number of cells with the ability to form a colony does not decrease significantly for an extended time. However, CC1335 wild-type does not behave like HCAT2 (the Nir deficient strain of HCNT1); CC1335 rapidly reduces its internal energy and the number of cells capable of forming a colony upon re-incubation under aerobic condition. These data suggest that strain CC1335 does not need Nir to reduce its internal energy (culturability) under anoxic conditions. The difference between these strains is interesting and suggests that HCNT1 has the ability to survive for a long periods without loss of ability to form CFU, but also that the presence of Nir leads to a reduction in internal energy to VBNC levels, making the strain more resistant to a variety of stresses.

Recent acquisitions

In order to confer a possible role to *nirK*, which could unequivocally explain the conservation of this peculiar gene in *R. sultae*, further hypothesis have been recently made. A defence mechanism for detoxification of selenite, was recently proposed (Basaglia *et al.*, 2007) This hypothesis is based on the observation that in some *R. sultae* strains the presence of *nirK* seems to be connected to the reduction of selenite to less toxic elemental selenium.

Selenium

Selenium is a common environmental element whose presence in soils and groundwater may be due to either natural or anthropogenic activities. In small amounts, inorganic selenium is an essential element; however, in large amounts, selenium toxicity can cause fatigue, irritability, and damage to the nervous system (<http://www.epa.gov/ogwdw000/dwh/t-ioc/selenium.html>, US Environmental Protection Agency, 2002). In humans, consumption of 50-200 µg Se/day is beneficial, but consumption of 850 µg Se/day can be injurious (Whanger, 2004). In the environment, selenium also plays a dual role being beneficial in low amounts but damaging at larger amounts. Human activities, such as coal mining and fuel refining, as well as industrial uses of selenium (e.g., in photocopy machines, electronics, glass manufacturing, chemicals and pigments) affect the biological availability of selenium.

Selenite (SeO_3^{2-}), common in environs that are moderately acidic and oxidizing (Plotnikov, 1958), is highly soluble and mobile in groundwater and it is the most toxic of the Se oxyanions (Doran, 1982). The greatest abundance of selenium is in igneous rocks, but high concentrations are also present in some sedimentary rocks and fossil fuels (Ohlendorf, 1989). The three main forms of elemental selenium, Se^0 , are red amorphous form, black amorphous form and grey hexagonal form. The red and black amorphous allotropes are the most likely forms occurring in soils. Red amorphous selenium originates when Se^0 precipitates in aqueous solution (Geering *et al.*, 1968). At temperature greater than 30°C, red amorphous Se^0 gradually reverts to the black amorphous form (Gattow and Heirich, 1964). This form is then slowly transformed into the much more stable grey hexagonal allotrope or is reoxidized, depending on the redox conditions and the pH of the soil. Oxidation can occur through inorganic reactions or by the action of microorganisms (Geering *et al.*, 1968).

In aerated soils and aquatic environments, selenium occurs predominantly in the form of selenite (SeO_3^{2-}) and selenate (SeO_4^{2-}) oxyanions, which are freely available to living organisms.

Many plants and microorganisms can transform inorganic selenium species into volatile organic selenium species (Wilber, 1990). Selenium is absorbed by plants and used especially in the synthesis of some proteins and amino acids (Shrift, 1973). The level of accumulation

depends, in addition to the available amount in the soil, on the plant, pH, salinity and content of calcium carbonate in the soil. Through plants, this element enters the food chain resulting potentially dangerous to animals and humans. Dimethylselenide is the most common volatile organic selenium species produced by microorganism (Zieve *et al.*, 1985; Frankenberger and Karlson, 1994).

Microorganisms convert Se from one form to another, and they play a key role in the environmental transformation of Se. Transformations might involve the conversion of the highly soluble and biologically available SeO_3^{2-} anion to insoluble and relatively non-available elemental selenium (Se^0). SeO_4^{2-} and SeO_3^{2-} are often encountered as contaminants of surface waters and ground water, and the reduction of these compounds to less toxic forms by microbial action represents an important emerging bioremediation concept. Also, some microorganisms can lessen the toxicity of the selenium oxyanions by reduction and methylation, a process that frequently yields volatile gases such as dimethylselenide (DMSe) or dimethyldiselenide (DMDS₂) (Ganther *et al.*, 1966). Only a few microorganisms that reduced Se oxyanions to Se^0 have been studied.

Selenium in cellular metabolism

Selenium is an analogous of sulfur and may substitute for sulfur in thiols. Thus it can be toxic at elevated concentrations. Nevertheless, it is an essential element for microorganisms (Heider and Böck, 1993). The requirement for selenite by *E. coli* in the production of formate dehydrogenase was recognized in the mid-1950s (Pinsent, 1954); however, it took several more decades before the precise nature of the requirement was discovered. The common biological forms are selenocysteine and selenomethionine. Selenocysteine is encoded by its own tRNA and provides the selenium in glycine reductase, formate dehydrogenase, and NiFeSe hydrogenase (Garcin *et al.*, 1999; Heider and Böck, 1993). Selenium is assimilated in yeast and plants via the sulfur assimilation pathway with selenate activated by ATP sulfurylase and subsequently converted to selenomethionine (de Souza, 2000). Although a similar mechanism has been proposed for prokaryotes, some studies have suggested specific mechanisms for the uptake of selenate and selenite (Stolz and Oremland, 1999). The reaction of selenite with glutathione produces

selenodiglutathione. Selenodiglutathione and its subsequent reduction to glutathioselenol are key intermediates in the transformation of selenium (Turner *et al.*, 1998). The use of selenium oxyanions as alternative terminal electron acceptors is energetically favourable. Although Se(IV) reduction to Se⁰ also occurs in nature, only the haloalkaliphilic *Bacillus selenitireducens* (Switzer Blum *et al.*, 1998) and three strains of an *Aquificales* species (HG MK-1, 2, and 3) (Takai *et al.*, 2003) that can respire selenite have been described. No respiratory selenite reductase has been reported to date. Selenium reduction to selenide (HSe⁻¹) has only recently been described (Herbel *et al.*, 2003). Far less is known about selenium oxidation. Studies on microbial selenium methylation and demethylation are also few in number (Dungan and Frankenberger, 1999; Favre-Bonte *et al.*, 2005; Gadd, 1993; McCarty *et al.*, 1993; Oremland and Zehr, 1986; Ranjard, 2003; Ranjard, 2004). Thus, many aspects of the biogeochemical cycle of selenium remain to be explored.

Methylation

Dimethylselenide and dimethyldiselenide are the most common forms of methylated selenium. In both cases, the selenium is in its fully reduced oxidation state (Se(-II)). This is unlike arsenic, in which the methylated species may contain arsenic in the V, III, or -III state. As with arsenic, methylation via a methyltransferase is a common mode of removal in prokaryotes (Heider and Böck, 1993). *Rhodocyclus tenuis* and *Rhodospirillum rubrum* produce both dimethyl selenide and dimethyl diselenide from selenate while growing phototrophically. *R. tenuis* also produces dimethyl selenide from selenite (McCarty *et al.*, 1993). Selenocysteine can be reduced to hydrogen selenide by reduced glutathione via selenocysteine-glutathione selenenyl sulfide (Sayato *et al.*, 1997). *E. coli* cells expressing the trimethyl purine methylase gene (*tmp*) from *Pseudomonas syringae* produced dimethyl selenide and dimethyl diselenide from selenate, selenite, and selenocysteine (Ranjard *et al.*, 2002). Recently, two different methyltransferases have been identified from species of *Pseudomonas*. The first is a bacterial thiopurine methyltransferase. The enzyme converts selenite and selenocysteine to dimethyl selenide and dimethyl diselenide. The second, a homolog of calichaemicin methyltransferase, produces dimethyl selenide and dimethyl diselenide from selenite and selenocysteine. The enzyme, MmtA, is defining a new group

of methyltransferases and has homologs in many species of bacteria (Ranjard *et al.*, 2003; Ranjard *et al.*, 2004).

***Rhizobium sullae* and the reduction of selenite**

Various enzymatic systems have been proposed to catalyze the reduction of selenite in bacteria. In *Thauera selenatis*, De Moll-Decker and Macy (1993), have suggested that the reaction might be catalyzed by a periplasmic dissimilatory reductase. They report that mutants, lacking periplasmic nitrite reductase activity, are unable to reduce either nitrite or selenite.

In different *R. sullae* strains containing *nirK* gene, it has been possible to evidence *nirK* activity and, at the same time, selenite reduction to elemental selenium. In contrast, in strains without *nirK* the ability to grow in the presence of selenite is very low or absent.

The mobilization of *nirK* gene from *R. sullae* HCNT1 to strains naturally lacking nitrite reductase determines a phenotype similar to HCNT1: the mutant strain is not able to grow in anaerobic conditions, reduces nitrite to NO and is able to reduce selenite to elemental selenium (Se⁰).

These data suggest on one hand a possible explanation for the presence of *nirK* gene, conserved in this peculiar strain but apparently useless, and, on other hand, a possible clarification for the radically truncated denitrification chain found exclusively in this bacterium: nitrite reductase of *R. sullae* provides either resistance to selenite in addition to nitrite reduction.

The objective of the present study was just to verify this hypothesis with the aim to unambiguously give a defined role to the conservation of *nirK* in *Rhizobium sullae* HCNT1.

Materials and methods

Bacterial strains and growth conditions

Strains and plasmids used in this work are reported in Table 1. *Rhizobium sullae* (formerly *Rhizobium hedysari*) HCNT1 (ATCC 43676) (Casella *et al.*, 1986), its mutant strain HCAT2 containing a *nirK* inactivated gene, (Toffanin *et al.*, 1996), *Rhizobium sullae* strain CC1335 and its mutant CC1335 (*nirK*⁺) containing a plasmid pRKAT7 with functional *nirK* gene were the rhizobia used.

Batch cultures of all rhizobial strains were grown aerobically in yeast mannitol (YM) medium (mannitol 10g/L, K₂HPO₄ 0,5 g/L, yeast extract 0.4 g/L, MgSO₄ 7H₂O 0,2 g/L, NaCl 0.1 g/L) and tryptone yeast extract (TY) medium (tryptone 5g/L, yeast extract 3 g/L, NaCl 0.7-0.9 g/L) at 30°C, under shaking. Antibiotics were added to cultures at the following concentrations: tetracycline 5 µg/mL; kanamycin 100 µg/mL in solid medium and 15 µg/mL in liquid medium. For cloning techniques and expression of the recombinant protein, *Escherichia coli* strains JM109 (laboratory collection) and M15 (QIAexpress, Qiagen) were used. Batch cultures of *E. coli* were grown aerobically in Luria-Bertani (LB) medium (tryptone 10 g/L, yeast extract 5 g/L, NaCl 5 g/L). Antibiotics were added to cultures at the following concentration: ampicillin 100 µg/mL; kanamycin 25 µg/mL.

Conservation of bacterial strains

The storage of bacterial strains was achieved in Eppendorf tubes containing aliquots of cultures in logarithmic phase with 20% of sterile glycerol kept at -80°C.

Table 1 - List of strains and plasmids used in this study.

Strains and plasmids	Relevant genotype or phenotype	Source or reference
<u>Strains</u>		
<i>R. sultae</i> HCNT1	wild type, Nir ⁺	Casella <i>et al.</i> , 1986
<i>R. sultae</i> HCAT2	Km ^r ; <i>nirK</i> interrupted by a single crossing-over of pAT3	Toffanin <i>et al.</i> , 1996
<i>R. sultae</i> HCAT3	HCAT2 (pRKAT7)	Toffanin <i>et al.</i> , 1996
<i>R. sultae</i> HCAT4	HCNT1 (pAT707)	Toffanin <i>et al.</i> , 1996
<i>R. sultae</i> HCAT5	HCAT2 (pAT707)	Toffanin <i>et al.</i> , 1996
<i>R. sultae</i> CC1335	wild type, Nir ⁻	Casella <i>et al.</i> , 1988
<i>R. sultae</i> CC1335/ <i>nirK</i>	CC1335 (pRKAT7)	Toffanin <i>et al.</i> , 1996
<i>E. coli</i> JM109	<i>F'</i> <i>traD36lacI^{fl} proA⁺B⁺/rpsL e14⁻(McrA⁻)Δ(lac-proAB) thi gyrA96 endA1 hsdR17(r_K- m_K) relA1 supE44</i>	Laboratory collection
<i>E. coli</i> JM109/ <i>nirK</i>	<i>E. coli</i> JM109; ~1.2-kb <i>Bam</i> HI- <i>Hind</i> III fragment <i>nirK</i>	This work
<i>E. coli</i> M15	<i>E. coli</i> (pREP-4)	QIAGEN [®] , 2003
<i>E. coli</i> M15/ <i>nirK</i>	<i>E. coli</i> M15; ~1.2-kb <i>Bam</i> HI- <i>Hind</i> III fragment <i>nirK</i>	This work
<u>Plasmids</u>		
pRK415	Km ^r	Keen <i>et al.</i> , 1988
pJP5603	Tc ^r <i>nirK</i> ; ~2,9-kb <i>Bam</i> HI- <i>Pst</i> I fragment in pRK415	Penfold and Pemberton, 1992
pRKAT7	Tc ^r Km ^r ; <i>nirK-lacZ</i> in pRK415	Toffanin <i>et al.</i> , 1996
pAT707	Km ^r ; ~0,6-kb internal <i>nirK</i> fragment generated by PCR	Toffanin <i>et al.</i> , 1996
pAT3	in pJP5603	Toffanin <i>et al.</i> , 1996
pREP-4	Neo ^r ; <i>lacI</i>	QIAGEN [®] , 2003
pQE-30	Ap ^r ; N-terminal 6xHis tag	QIAGEN [®] , 2003
pGEM-T	Ap ^r ; <i>lacZ</i>	Promega
pGEM-T/ <i>nirK</i>	pGEM-T; pQE-30; ~1.2-kb <i>Bam</i> HI- <i>Hind</i> III fragment <i>nirK</i>	This work
pQE-30/ <i>nirK</i>	pQE-30; ~1.2-kb <i>Bam</i> HI- <i>Hind</i> III fragment <i>nirK</i>	This work

(Km^r, kanamycin resistant; Tc^r, tetracycline resistant; Ap^r, ampicillin resistant; Neo^r neomycin resistant)

Plate growth with selenite

Aliquots of cultures grown in YM or TY broth were transferred to YM or TY agar plates, containing 5, 25 and 50 mM Na₂SeO₃. Plates were incubated aerobically at 30°C and, after 48 hours, the appearance of red colonies was considered to indicate the reduction of selenite to elemental selenium, Se⁰ (Moore and Kaplan, 1992; Sabaty *et al.*, 2001).

Growth of bacterial strains in liquid culture with selenite

In order to investigate the sensitivity of the bacterial strains to selenite, liquid cultures containing 5, 25 and 50 mM Na₂SeO₃ were prepared. Growth was carried out aerobically and anaerobically at 30°C with constant agitation (140 rpm) in 100 mL Erlenmeyer flasks containing 50 mL YM or TY broth. The flasks were inoculated with 100 µL of late log phase cells. Growth was measured by monitoring the OD of the culture at 600 nm, after 24, 48, 72 hours of incubation.

All measurements were done in triplicate.

Reduction of selenite under different incubation conditions

The cells used as the inoculum in all cases derived from a late log phase aerobic starter culture. The experimental samples were prepared in two different ways: (i) in one case 30 mL of starter culture was centrifuged at 5000 g for 10 minutes, washed with 0.9% saline solution and inoculated into 250 mL flasks containing 125 mL YM. The flasks were then sealed with rubber stoppers and the headspace was flushed aseptically with a gas mixture of 5% O₂ and 95% N₂ (v/v). After 48 hours of incubation, the cells had reduced the available oxygen and consequently had Nir activity. The incubation was continued anaerobically or aerobically, in either saline or YM. When necessary, anaerobic conditions were maintained during the change of media. Aerobic conditions were achieved by replacing the rubber stoppers with a foam stopper and agitation of the culture. In these experiments, sterile Na₂SeO₃ was added to give a final concentration of 25 mM. The appearance of red colour, indicating selenite reduction, was monitored visually. Incubations were carried out at 30°C

on three replicates for each condition. (ii) In the other case, 30 mL of the starter culture was centrifuged at 5000 g for 10 minutes, washed and resuspended with 0.9% saline solution or YM broth to a final OD₆₀₀ of 0.5. Eight millilitres aliquots of the cell suspension were incubated either aerobically or under strictly anaerobic conditions. Sterile Na₂SeO₃ was added at the start of incubation to a final concentration of 25 mM. The presence or the absence of a red colour in broth was recorded after incubation at 30°C within 24-48 hours.

The induction of *nirK* activity in *Rhizobium sllae* strains

The induction of nitrite reductase activity was obtained as described by Toffanin *et al.* (2000).

For nitrite reductase induction, 30 ml late-log-phase grown cells, were centrifuged at 5000 g for 10 minutes, diluted to give an initial optical density of 0.6 at 600 nm and inoculated in 120 ml YM in 250 ml Erlenmeyer flask sealed with rubber stoppers and flushed aseptically with a gas of 5% O₂ and 95% N₂ (v/v). After approximately 48 hours, nitrite reductase induction was verified by adding 1 mM KNO₂ and by measuring NO₂⁻ disappearance (Stewart and Parales, 1988).

Nitrite Reductase Assay

The consumption of nitrite, in cultures grown under oxygen limited conditions, was determined using by the method of Stewart and Parales (1988).

Aliquot of 50 µL of nitrite containing microbial culture is mixed with 1 mL of sulfanilic acid/HCl and 1 mL of N-(1-Naphthyl)ethylenediamine (NED). After 10 minutes of incubation at room temperature, the nitrite concentration is detected reading A₅₄₀. Calibration is realized with 3.6 to 36 µM KNO₂ concentrations. The presence of nitrite in the solution was revealed by a red-violet color, while the complete consumption of NO₂⁻ leave the suspension totally colourless.

Preparation of cell-free extracts

Rhizobial cells, grown in YM or TY broth at 30°C under shaking, were washed, resuspended in phosphate saline buffer (PBS) and homogenized with the aid of a cell disruptor (Constant Cell Disruption Systems) at 2.5- 3 Kbar; the homogenate was centrifuged at 12000 rpm for 20 minutes to remove cellular debris and unbroken cells.

Cultures of *Escherichia coli* were grown in LB medium and homogenized at 0.5-1 Kbar.

β-Galactosidase assay

To investigate whether the promoter of the *nirK* gene is induced by microaerophilic condition or by the presence of selenite substrate, a β-galactosidase assay was carried out, using strains HCAT4 and HCAT5 of *R. sultae*, deriving respectively from HCNT1 and its mutant HCAT2 transformed with pAT707 plasmid, carrying the *nirK-lacZ* fusion.

β-galactosidase can be assayed by measuring the rate of hydrolysis of the chromogenic substrate, o-nitrophenyl-β-D-galactoside (ONPG) (Miller, 1972). The amount of o-nitrophenol formed can be measured by determining the absorbance at 420 nm. If excess ONPG is added, the amount of o-nitrophenol produced is proportional to the amount of β-galactosidase and the time of the reaction. The reaction is stopped by adding Na₂CO₃ which shifts the reaction mixture to pH 11. At this pH most of the o-nitrophenol is converted to the yellow coloured anionic form and β-galactosidase is inactivated. The reaction can be run using whole cells that have been permeabilized to allow ONPG to enter the cytoplasm. However, since whole cells are present, the absorbance at 420 nm is the sum of the absorbance due to o-nitrophenol and light scattering due to the cells. The contribution of light scattering can be determined by measuring the absorbance at 550 nm where o-nitrophenol does not absorb. The light scattering at 420 nm is 1.75 x the light scattering at 550 nm, so the absorbance of o-nitrophenol is determined by subtracting 1.75 x OD₅₅₀ nm. The corrected absorbance is then used to calculate the activity of β-galactosidase (Figure 1).

$$\beta\text{-galactosidase activity/min mL} = \frac{1000 \times [A_{420} - (1.75 \times A_{550})]}{\text{reaction time} \times A_{660} \times \text{volume of buffer Z}}$$

Figure 1 - Formula used to calculate β -galactosidase activity, according to Miller (Miller, 1972).

β -galactosidase activities were determined in triplicate on at least four independently grown cultures. Cells removed from sealed flasks were not kept anaerobically but were used immediately for assay.

Determination of protein content

The protein content of the bacterial cultures were determined by using Coomassie Plus Kit (Pierce), that is based on a modification of the colorimetric method of Bradford (Bradford, 1976), and bovine serum albumin as the standard. The binding of the Coomassie Plus reagent to protein causes a shift in the absorption maximum of the dye from 465 to 595 nm, and it is the increase in absorption at 595 nm which is monitored.

All measurements were done in triplicate.

Gas-chromatograph analysis

From the headspace of cultures sealed with rubber stoppers, gas samples of 500 μ L were taken with a gastight syringe and were directly applied to the gas chromatograph (Thermo, GC-Trace model) equipped with a Ni electron capture detector (ECD). Nitrous oxide (nitric oxide has a little hemilife) concentration was determined by using a 30 m-length CP-PoraPLOT Q column (Chromopack, Varian), with 0.53 mm inner diameter. Temperatures of analysis were 300°C for the detector and 150°C for the injector port. Oven temperature was 40°C. The carried gas was helium at a flow rate of 7.2 mL/min. For the external

standard nitrous oxide (Micro Mat 10, Matheson Tri-Gas) was used, and a standard curve was produced from a series of N₂O dilutions.

For determination of nitrite reductase activity, methyl-viologen (MV⁺) was used as an artificial electron donor, which action is limited to the periplasmic space of intact cells, in each sample together with nitrite, selenite or both nitrite and selenite at different concentrations. Aliquots of phenazine methosulfate (PMS) and ascorbic acid can be used in place of methyl-viologen.

The GC measurements were taken at different times and in triplicate.

Agarose gel electrophoresis

Polymerase chain reaction (PCR) products were analysed by agarose gel electrophoresis 0.8% agarose in 1xTAE (40 mM Tris acetate, 2 mM EDTA, pH 7.6) containing 0.2 mg/mL ethidium bromide at a constant 100 V.

Nucleic acids were visualized by UV transillumination.

Isolation of genomic DNA from *R. sultae* strain HCNT1

Chromosomal DNA of *R. sultae* HCNT1 was obtained from bacterial culture following the standard methods described by Sambrook *et al.* (1989).

PCR amplification of *nirK* fragment and *nirK* CDS

A 326 bp fragment of *nirK* gene was amplified from chromosomal DNA of *R. sultae* HCNT1 using the designed primer pairs *nirK1* (5') TCA TGG TGC TGC CGC GKG ACG G (3') and *nirK2* (5') GAA CTT GCC GGT KGC CCA GAC (3') (Yan *et al.*, 2003), whereas *nirK* coding region (CDS) was amplified using primers *nirK* Fw (5'- GGA TCC ACA AAT ACA TTG CAA ATG ACC CGG -3') and *nirK* Rv (5'- AAG CTT GCT ACC

CGA TGG CGA CCT -3'), specially designed for the following cloning procedures. The primers were supplied by MWG Biotech.

PCR reaction mixture contained 0.2 of each dATP, dCTP, dGTP and dTTP, 1x buffer with MgCl₂ 1.5 mM, 1 µL of each primer and 2.5 U *Taq* DNA Polymerase (Amersham Bioscience).

Settings for amplification were: 94°C for 2 minutes and then 30 cycles of 94°C for 30 seconds (denaturation), 55°C for 60 seconds (annealing), 72°C for 60 seconds (extension); the final extension time was at 72°C for 5 minutes. PCR reactions were performed in a total volume of 25 µL in a model 480 thermal cycler (Perkin Elmer DNA thermal cycler).

Purification of DNA fragments from agarose gel and sequencing

PCR amplicon band of interest were carefully excised from agarose gel by using a clean razor blade, trimming the excess of agarose from DNA band to maximize recovery and purity. The PCR fragments were then purified from gel slices using Quantum PrepTM Freeze 'N Squeeze DNA Gel Extraction Spin Columns (Bio-Rad), as described by the manufacturer, and sequenced. One µL of the purified amplicon was mixed with 1 µL containing 6.4 picomoles of the forward primer *nirK* Fw (5'- GGA TCC ACA AAT ACA TTG CAA ATG ACC CGG -3') in a 0.2 mL polypropylene tube and then dried by incubating tube open for 15 minutes at 65°C in an *i*-cyclor thermal cycler (Bio-Rad). Template and primer mixture was directly used di-deoxy-cycle DNA sequencing with fluorescent terminators (Big Dye, Perkin-Elmer/Applied Biosystem, Foster City CA) and run in an Applied Biosystem ABI Prism3730XL automated DNA sequencer.

Chromatograms were analyzed by Chromas 2.23 software (Technelysium Pty Ltd., Tewantin Australia).

RNA extraction and cDNA synthesis

Total RNA was extracted from aerobic and microaerophilic cultures using the RNeasy[®] Mini Kit (Qiagen) following the manufacturer instructions, quantified with a

spectrophotometer, and run on 1.2% agarose gel to check its integrity. Microbial RNA was treated with a RNA-protector (Qiagen). The extract RNA was treated with RNase-free DNase I (AB, Applied Biosystems-Ambion) and RNase Inhibitor (Amersham Pharmacia Biotech Inc.) for 30 minutes then purified by phenol-chloroform and precipitated in isopropyl-alcohol as described by Sambrook and Russel (2001).

Double-stranded cDNA was synthesized from 0.1 µg of DNA-free total RNA using the *C. therm.* Polymerase One Step RT-PCR System (Roche Applied Science). The reaction mixture contained dNTP mix 0.4 mM of each, DMSO 7%, DTT solution 5 mM, RNase Inhibitor (Amersham Pharmacia Biotech Inc.) 20 U, upstream primer 0.3 µM, downstream primer 3 µM, template RNA 0.1 µg, 5x RT-PCR buffer, 2 µL of *C. therm.* Polymerase mixture (Roche Applied Science) at a given concentration and sterile water to a final volume of 50 µL. The primer used for cDNA synthesis from *nirK* mRNA was (5') TCA TGG TGC TGC CGC GKG ACG G (3'), 22 oligo for top strand, and (5') GAA CTT GCC GGT KGC CCA GAC (3'), 21 oligo for bottom strand (Yan *et al.*, 2003).

RT reaction was carried out in a thermocycler equilibrated at 60 °C and the samples were incubated for 30 minutes. Temperature up to 72 °C can be used to eliminate secondary structures of RNA and to reduce unspecific primer binding.

For PCR reaction settings were initially 94°C for 2 minutes and then 30 cycles of 94°C for 30 seconds (denaturation), 55°C for 60 seconds (annealing), 72°C for 60 seconds (extension); the final extension time was at 72°C for 5 minutes.

Contamination with genomic DNA was excluded by using RNA preparation directly in PCR (no reverse transcriptase control). The integrity of RT-PCR was demonstrated by amplifying 16S. The PCR amplified products were visualized by ethidium bromide staining on 1.2% agarose gel.

Primer design for CDS amplification of *nirK* gene

The primers for amplifying the coding region (CDS) of *nirK* were designed on the basis of the sequence found in NCBI (<http://www.ncbi.nlm.nih.gov>) database (Figure 1). The primers were chosen with the aid of Primer3 program, in the web site

<http://www.genome.wi.mit.edu> (Rozen and Skaletsky, 1998). The coding region of *nirK* gene is 1133 nucleotides-length, included between position 131 and 1264 (Figure 2).

The primers were designed by excluding Start and Stop codons and the ribosome binding site (RBS), since they are already present in the expression vector pQE-30, provided by The QIAexpressionist™ kit (Qiagen), and used subsequently for cloning. Start and Stop codons, together with RBS, if present, might cause an incorrect fusion between His-tag (6xHis) and the coding region of *nirK* gene.

The forward (sense) and reverse (anti-sense) primers were tailed with restriction sites for cloning the PCR products between the *Bam*HI and *Hind*III of pQE-30 plasmid.

```

1  GAGCAGTGAC GCGACTTTGT GCTCCCACAA AGACCGAATT TGCTCCAAAT CAAAGAGATT
61  ACGCACCATT CTCCTAGAAC TCTTGTGACC GGGCGGGTTC CGCTCCGTCT TCGACTTCAG
121 GAGAAGAATG ATGACAAATA CATTGCAAAT GACCCGGGCGC ACGATGCTGA CGGGCGCTGC
181 TGTGCGCGGA GCGCTGACCC CCATCCTCAC CTCGGGGGGG GGAATGCCT CCCCCACTCC
241 TGTCAGAAAG CTCAGCGCCA CTGAAATCGC TGCCCTCCG CGCAGGAAAC TGGACCTCGT
301 GAAGCCACCT TTCGTCCACG TACATACGCA AAAAGCAGAA GCGGACCGA AAGTCGTCGA
361 AGTCACACTG ACGATCGAGG AAAAGAAGCT CGTGATCGAT GGCAAGGGCA CCGAAGTCAA
421 TGCCATGACC TTTGACGGAT CGGTTCTCTG TCCGCTCATC GTTGTGCATC AGGACGACTA
481 CGTCGAGGTC ACACTCGTCA ATCCCGAGAC GAACACGCTG CAGCACAAAC TCGATTCCA
541 CTCAGCAACC GGTGCGCTCG GCGGCGGTGC ACTGACGGTC GTCAACCCGG GTGAGAGCGC
601 GGTATTGCGC TTCAAGGCGA CCAAGGCGGG CGTCTTCGTC TATCACTGCG CCCCTCCCGG
661 CATGGTACCT TGGCACGTAA CCTCGGGCAT GAACGGGCGG ATCATGGTGC TGCCGCGCGA
721 AGGTCTGACA GATGGCCATG GCAAGGAACT TGTCTACGAC AAGGTCTATT ACCTCGGTGA
781 GCAGGACTTT TATATTCCGC GCGACGAAAA GGGCGAGTTC AAAAAATATG ACAGCCCGGG
841 TGAGGCTTAT GAGGATACCG TCGCCGTCAT GCGTACCTTG ACCCCGACGC ATATTGTCTT
901 CAATGGCGCC GTGGGCGCGC TCACCGGTGA AAATGCTCTG ACGGCTGCGG TCGGCGAGCG
961 GGTCTCTATC GTTCACTGCG AAGCCAACCG TGACACCCGG CCGCATCTTA TCGGCGGTCA
1021 TGCGGAATAT GTCTGGCGCA CGGGCAAGTT CGTCAACGTG CCCGACCGGG ATCAGGAGAC
1081 CTGGTTCATT CCGGGGCCCA CACGCGGGGC GGCCTACTAT ACGTTCGAAC AGCCCGGTAT
1141 CTATGCCTAT GTCAACCATA ATCTGATCGA GGCTTTCGAG CTTGGGCGTG CGGCTCACTT
1201 CAAGGTCACC GGTGATTGGA ACGACGATCT AATGACCACC GTCAGGTCGC CATCGGTTAG
1261 CTGATCCAGA CAGTTCATGC CGGCGAGCGG ACCAGGATGT AGCCCGCTCC GGAATTTCCA
1321 CGTGAGGCGC CTTCAAACGC GATCGCTGTG ATACGAATCG GATGATCAGG TTTCGGGAAT
1381 TTCCATCGCC ATACCGCTGG TGCTGTTGGC GATCCTGCTA GCATCGGTGC CCGTTCAGTC
1441 CGGCCTAGTC GCCTTGGCTG GGCTCAGAA TCGGTCGCCA GTCAGATGTG ATTACGTGT

```

Figure 2 - Sequence of *nirK* gene, available on NCBI database. CDS region, coding for Nir protein in *R. sulae* HCNT1, is 1133 nucleotides-length, from position 131 (start codon, underlined) to 1264 (stop codon, underlined).

Plasmid and strain construction

All molecular cloning procedures were performed according to Sambrook *et al.* (Sambrook *et al.*, 1989). A 1.2-kb fragment of the coding region of *nirK* gene was amplified from chromosomal DNA of *R. sultae* strain HCNT1 with the primers *nirK* Fw (5'- GGA TCC ACA AAT ACA TTG CAA ATG ACC CGG -3') and *nirK* Rv (5'- AAG CTT GCT ACC CGA TGG CGA CCT -3'), carrying restriction site respectively of *Bam*HI and *Hind*III (Figure 3).

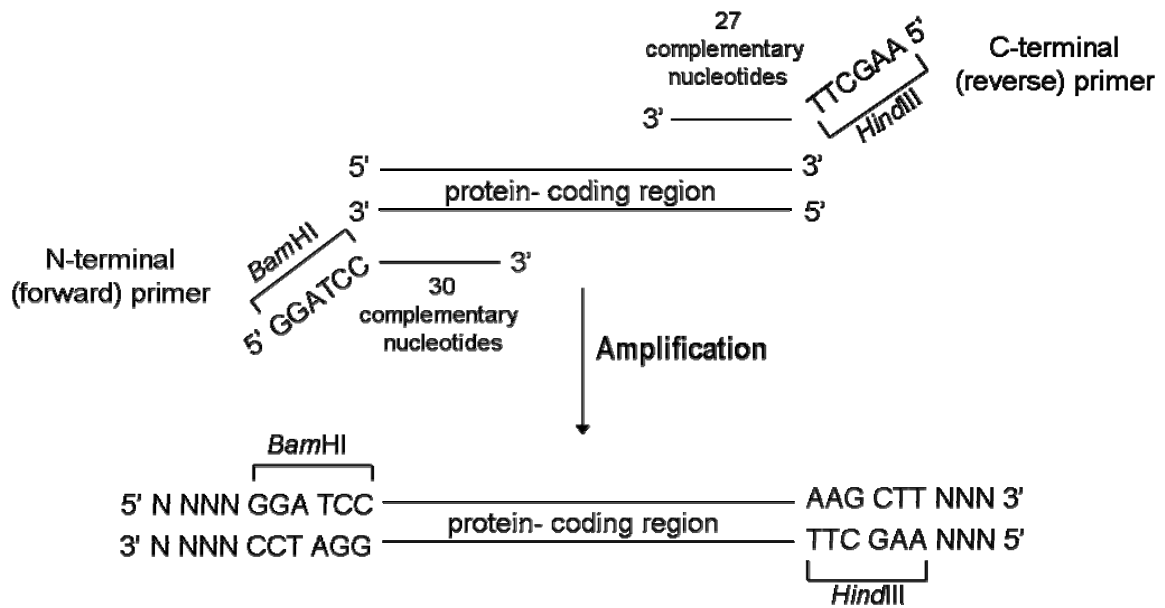

Figure 3 - Amplification of *nirK*-coding region of *R. sultae* HCNT1, using primers Fw (5'- GGA TCC ACA AAT ACA TTG CAA ATG ACC CGG -3') and *nirK* Rv (5'- AAG CTT GCT ACC CGA TGG CGA CCT -3'), that carry restriction sites respectively of *Bam*HI and *Hind*III (underlined).

The PCR product (Figure 4A) was cloned into pGEM-T vector (Figure 4B) exploiting 3'-A overhangs generated by *Taq* polymerase and using T4 ligase enzyme (Promega).

The resulting plasmid, pGEM-T/*nirK* (Figure 4C) was digested with *Bam*HI and *Hind*III to control the presence of the restriction sites, and the fragment containing the *nirK* gene was

recloned into the expression plasmid pQE-30 (The QIAexpressionist™, Qiagen) restricted with the same enzymes; these restriction sites were comprised in the multiple-cloning-site (MCS) of the expression vector (Figure 4D). The plasmid obtained was used to transform *E. coli* JM109 with the electroporation method. The expression plasmid was extracted in large quantity by MidiPrep (Qiagen), controlled for the presence of *nirK/BamHI-HindIII* and reused to transform *E. coli* M15 with the RuCl method. Cells M15 strain contain a plasmid, pREP-4, which confers kanamycin resistance and constitutively expresses *lac* repressor protein encoded by the *lacI* gene (Farabaugh, 1978). The pREP-4 plasmid is derived from pACYC and contains the p15A replicon. Multiple copies of pREP-4 are present in the host cells that ensure the production of high levels of the *lacI* repressor protein which binds to the operator sequence and tightly regulates recombinant protein expression.

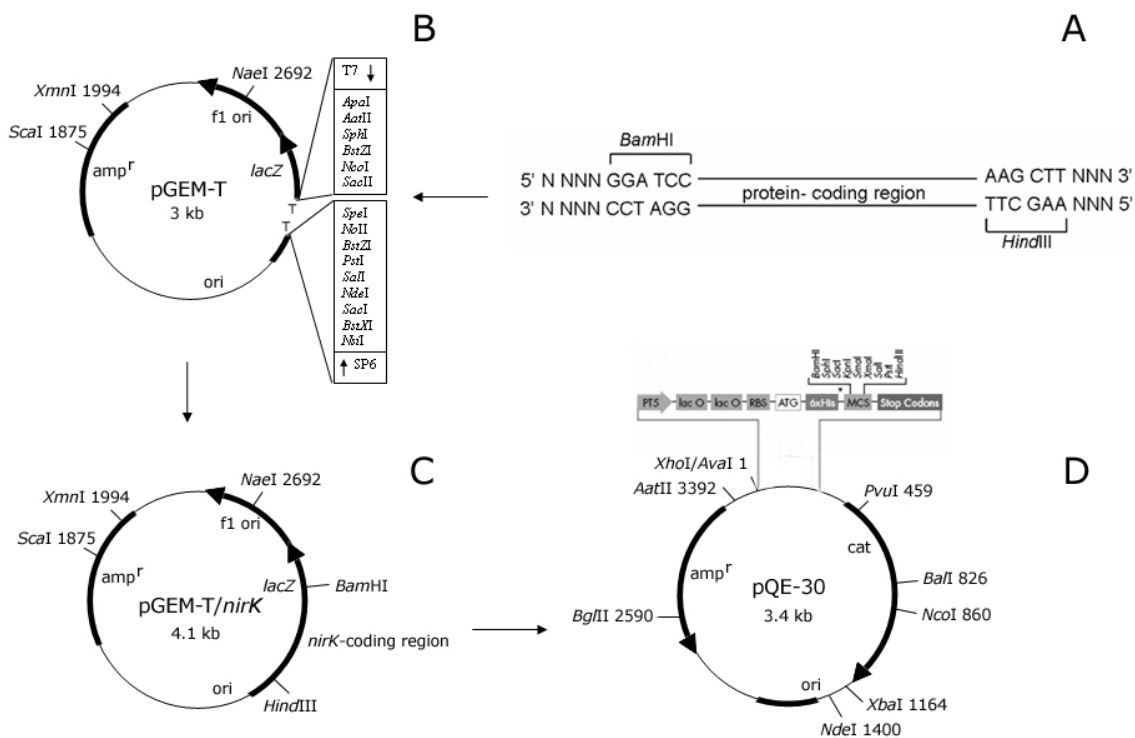

Figure 4 - Steps for plasmid construction to obtain the expression vector pQE-30/*nirK*.

Preparation of electro-competent *E. coli* JM109 cells

Electro-competent cells were prepared in the following way: 250 mL of fresh LB broth were inoculated with 2.5 mL of *E. coli* culture grown overnight at 37°C. The cells were grown at 37°C with shaking (200 rpm) to an OD₆₀₀ of 0.5 to 0.6, chilled on ice for 15-30 minutes for stopping the growth and then transferred to a pre-chilled centrifuge bottles. Cells were kept at 4°C for all subsequent steps. Cells were harvested by centrifugation at 4000 rpm at 4°C for 20 minutes, resuspended in a volume of ice-cold distilled water equal to the original culture volume and mixed well. The cell suspension was centrifuged once more at 4000 rpm at 4°C for 20 minutes. The supernatant was discarded and cell pellet resuspended in another volume of ice cold sterile water equal to the original culture volume and mixed well. The suspension was placed in an appropriately-sized, narrow tube that has been pre-chilled and an amount of ice-cold 10% glycerol equal to 0.8 of original culture volume was added. After a centrifuge at 4200 rpm at 4°C for 10 minutes supernatant was discarded and the pellet's volume estimated. An equal volume of ice-cold 10% glycerol was added in order to resuspend the pellet. Aliquots of 80 µL of the cells were placed into pre-chilled microcentrifuge tube and stored at -80°C.

Preparation of competent *E. coli* M15 cells

For the preparation of competent *E. coli* M15 cells, 1 mL of overnight culture was added to 100 mL of prewarmed LB medium containing 25 µg/mL kanamycin in a 250 mL flask, and the culture was shaken at 37°C until an OD₆₀₀ of 0.5 was reached. The cells were cooled on ice for 5 minutes, transferred to a sterile, round-bottom centrifuge tube and collected by centrifugation at low speed (5 minutes, 4000 x g, 4°C). Pellet was gently resuspended in cold (4°C) transformation buffer TFB1, (100 mM RbCl, 50 mM MnCl₂, 30 mM potassium acetate, 10 mM CaCl₂, 15% glycerol; pH 5.8) and the suspension was kept on ice for additional 90 minutes.

The cells were collected again by centrifugation (5 minutes, 4000 x g, 4°C) and resuspended carefully in 4 mL ice-cold transformation buffer TFB2 (10 mM MOPS, 10 mM RbCl, 75 mM CaCl₂, 15% glycerol; pH 6.8).

Aliquots of 100-200 μL were prepared in sterile microcentrifuge tubes, frozen in liquid nitrogen and stored at -80°C .

Isolation of DNA plasmid of *E. coli*

Plasmids were isolated using Qiagen Plasmid Mini Kit (Qiagen, Hilden, Germany). Purified plasmids were tested for inserts by *Bam*HI and *Hind*III digestion (MBI Fermentas, Heidelberg, Germany). Digestion was set using the following protocol: 10x buffer K for *Bam*HI and *Hind*III 2 μL , purified plasmid 5 μL , restriction enzymes *Bam*HI and *Hind*III (10 U/ μL) 0.1 μL , sterile MilliQ water to a final volume of 20 μL . Digestion reaction was incubated at 37°C for 2-3 hours. The digested products were checked on 1% agarose gel at 100 V.

Transformation of *E. coli* strain JM109

Transformation of *E. coli* strain JM109 was performed by electroporation method, following the procedure described by Dower *et al.*, 1988. The electroporation apparatus (*E. coli* Pulser Apparatus) was set to 2.5 kV, 25 μF and the pulse controller to 200 Ω . To transform JM109 cells 1 μL of pGEM-T/*nirK* construct was added to 80 μL of frozen electro-competent cell, previously thawed on ice. The volume of DNA added to the cells should be kept small, to increase the efficiency of electroporation. DNA and cells were then transferred into a pre-chilled electroporation cuvette (0.2 cm electrode gap) that was wiped and placed into the sample chamber of the electroporation. After the pulse 1 mL of SOC medium (2% Bacto-triptone, 0.5% Bacto yeast extract, 10 mM NaCl, 25 mM KCl, 50 mM MgCl_2 , 20 mM glucose) was added to the sample and immediately transferred to a sterile polypropylene culture tube. The electroporation mixture incubated for 30 to 60 minutes at 37°C under moderate shaking to allow plasmid expression. Replicates of 100 μL were plated on LB-agar plates supplemented with 100 $\mu\text{g}/\text{mL}$ ampicillin, 200 $\mu\text{g}/\text{mL}$ IPTG and 20 $\mu\text{g}/\text{mL}$ X-Gal (5-bromo-4-chloro-3-indolyl- β -D-galactoside). Plates were incubated at 37°C overnight. Transformants that contained an insert were identified by blue/white

screening and white colonies were plated onto fresh LB agar containing ampicillin and screened for the presence of insert DNA by PCR.

Transformation of *E. coli* strain M15

Escherichia coli M15 cells were transformed with the RuCl method.

To transform competent M15 cells, an aliquot of ligation mix (10 µL), containing pQE-30/*nirK* *Bam*HI-*Hind*III fragment, was transferred into 100 µL of frozen M15[pREP-4] cells and the suspension was mixed carefully and kept on ice for 20 minutes. The cells were transferred to a 42°C water bath or heating block for 90 seconds, then 500 µL of Psi broth (LB medium, 4 mM MgSO₄, 10 mM KCl) was added. The tube was incubated for 60-90 minutes at 37°C, under shaking for increasing transformation efficiency. LB-agar plates, containing 25 µg/mL kanamycin and 100 µg/mL ampicillin, were plated out with 50, 100 and 200 µL aliquots, and incubated at 37°C overnight. Transformants grown were then selected and controlled for the presence of *nirK* insert.

Bacterial expression of 6xHis-tagged recombinant protein

The recombinant proteins were expressed and prepared in small (200mL) culture of *E. coli* according to The QIAexpressionist IV handbook (Qiagen GmbH, Germany). The protein expression was induced by 1 mM IPTG for 4-5 hours. The strain of *E. coli* tested to obtain the optimal expression was M15.

Polyacrylamide gel electrophoresis in the presence of SDS (SDS-PAGE)

Proteins were separated by sodium dodecyl sulfate (SDS)-PAGE, (Laemmli, 1970) using Mini-PROTEAN[®] 3 Cell apparatus (Bio-Rad, Laboratories, Inc.), and subsequently visualized by staining with Coomassie brilliant blue R250.

Time-course analyses of protein expression

In order to establish the optimal conditions for the induction of the recombinant protein during the culture growth, it is necessary to check the 6xHis-tagged proteins present at various times after the induction. During the induction phases, with IPTG, aliquots of 1 mL were removed at different times, until four or five hours, lysated and centrifuged to separate soluble from insoluble fraction.

Determination of target protein solubility

To establish the target of protein solubility, 50 mL of prewarmed LB medium with antibiotics (kanamycin 25 µg/mL and ampicillin 100 µg/mL) was inoculated with 2.5 mL of overnight preculture of transformed *E. coli* M15, and grown at 37°C, with vigorous shaking (~300 rpm). When the OD₆₀₀ reaches approximatively the value of 0.5-0.7, IPTG (isopropyl-β-D-thiogalactopyranoside) was added to the final concentration of 1 mM, to induce the expression of the recombinant protein. After 4-5 hours from induction, the cells were harvested by centrifugation at 4000 x g for 30 minutes and resuspended in 5 mL of lysis buffer (50 mM NaH₂PO₄, 300 mM NaCl, 10 mM imidazole; pH 8.0), suitable for the purification of protein under native conditions. The samples were frozen in dry ice/ethanol, and thawed in cold water, then disrupted with a cell disruptor using a pressure of 1 Kbar.

The lysate was centrifuged at 10000 x g at 4°C for 20-30 minutes to separate the supernatant, containing soluble protein, from pellet containing insoluble protein. Pellet was resuspended in 5 mL of lysis buffer, and both soluble fraction and insoluble matter were analysed by SDS-PAGE.

For SDS-PAGE analysis, 5 µL of each fraction of crude extract were mixed to 5 µL of 2x SDS-PAGE sample buffer (0.09 M TrisCl, pH 6.8; 20% glycerol; 2% SDS; 0.02% bromophenol blue; 0.1 M DTT), heated along with the frozen noninduced and induced cell samples at 95°C, centrifuged at 15000 x g for 1 minute and loaded on a 12% SDS-PAGE gel.

***E. coli* culture growth for preparative purification**

E. coli culture grown overnight at 37°C was used to inoculate 200 mL LB broth supplied with 100 µg/mL ampicillin and 25 µg/mL kanamycin. The culture was grown at 37°C with vigorous shaking until an OD₆₀₀ of 0.6 was reached. To induce the expression of the recombinant protein IPTG was added to a final concentration of 1 mM. Before induction, 1 mL of culture was taken (non-induced control) and the cell pellet resuspended in 50 µL of 5x SDS-PAGE sample buffer (0.225 M TrisCl, pH 6.8; 50% glycerol; 5% SDS; 0.05% bromophenol blue; 0.25 M DTT) and frozen until the use.

The culture was incubated for an additional 4-5 hours. A second sample of 1 mL was taken, centrifuged, resuspended in 100 µL of 5x SDS-PAGE buffer and frozen (induced control).

The cells were harvested by centrifugation at 4000 x g for 20 minutes, and the pellet stored overnight at -20°C.

Preparation of cleared *E. coli* lysates under denaturing conditions

Cell pellets, obtained from *E. coli* culture for the following purification, were thawed for 15 minutes on ice and resuspended in a buffer for purification under denaturing conditions (100 mM NaH₂PO₄, 10 mM Tris-Cl, 8 M urea, pH 8.0), at 5 mL per gram of wet weight. Cells were then stirred for 60 minutes at room temperature, taking care to avoid the foaming. Lysis is complete when the solution becomes translucent. The lysate was centrifuged at 10000x g for 20-30 minutes at room temperature to pellet the cellular debris. The supernatant (cleared lysate) was ready to be used for batch purification of the recombinant protein under denaturing conditions.

Batch purification of 6xHis-tagged proteins from *E. coli* under denaturing conditions

The purification of histidine-tagged Nir was carried out following the methods provided by The QIAexpressionist™ (Qiagen) kit, under denaturing conditions.

Cleared lysate (1 mL), previously prepared from *E. coli* culture and containing the recombinant proteins, was added to 4 mL of Ni-NTA resin (Qiagen) and gently mixed by shaking for 60 minutes at room temperature to promote the binding between 6xHis-tag and Ni-NTA matrix. The amounts of lysate required depends on the expression level of the 6xHis tagged proteins and the expression system used.

Lysate-resin mixture was then carefully loaded into a Ni-NTA column (Qiagen) and the flow-through was collected. The column was washed twice with a wash-buffer (100 mM NaH₂PO₄, 10 mM Tris-Cl, 8 M urea; pH 6.3) and the fractions were collected. The 6xHis-tag recombinant proteins were eluted by the use of two elution buffers (100 mM NaH₂PO₄, 10 mM Tris-Cl, 8 M urea) at different pH values (5.9 and 4.5 respectively) and each fraction was collected for electrophoresis analysis in sodium dodecylsulfate-containing 12% polyacrylamide gels and for the following *in vitro* analysis.

Refolding of purified Nir protein

The collected fractions containing 6xHis-tagged protein, monomers or aggregates of monomers, were dialysed to remove denaturants, such as urea, and used to undertake *in vitro* experiments for evaluating nitrite and selenite reduction ability of the purified protein. Refolding was carried out overnight by dialysis against ice-cold phosphate buffer saline, PBS (pH 8.0), using regenerate cellulose (RC) dialysis membranes (Spectra/Por[®], Spectrum Laboratories Inc.) with a cut-off of 3500 Da.

Results and discussion

Growth of *Rhizobium sullae* in presence of selenite

Rhizobium sullae strains HCNT1 and CC1335, and their related mutants HCAT2/*nirK*⁻ and CC1335/*nirK*⁺ were cultured with increasing concentrations of selenite (5, 25, 50 mM). The appearance of red colonies, after about two days of incubation at 30°C, can be considered, according to literature, an indication of the reduction of SeO₃²⁻ to Se⁰ (Moore and Kaplan, 1992; Sabaty *et al.*, 2001).

Various bacteria have shown the capacity to reduce both selenite and nitrite (DeMoll-Decker and Macy, 1993; Kessi, 2006). While examining rhizobial strains for the ability to reduce selenite, it was observed that selenite reduction occurred in concomitance with nitrite reduction in some strains of *Rhizobium sullae*.

Strain HCNT1 is able to reduce nitrite to nitric oxide once *nirK* has been induced under oxygen limiting conditions. However, strain HCNT1 is unable to grow at the expense of nitrite as an electron acceptor (Casella *et al.*, 1986; Toffanin *et al.*, 1996).

Cells of wild type HCNT1, grown in medium containing 5-50 mM Na₂SeO₃, turned red, revealing that selenite was reduced to elemental selenium (Figure 1). The reduction of the oxyanion was also tested in the presence of 1, 5 and 10 mM nitrite; the production of red elemental selenium was similar to that observed in the absence of nitrite.

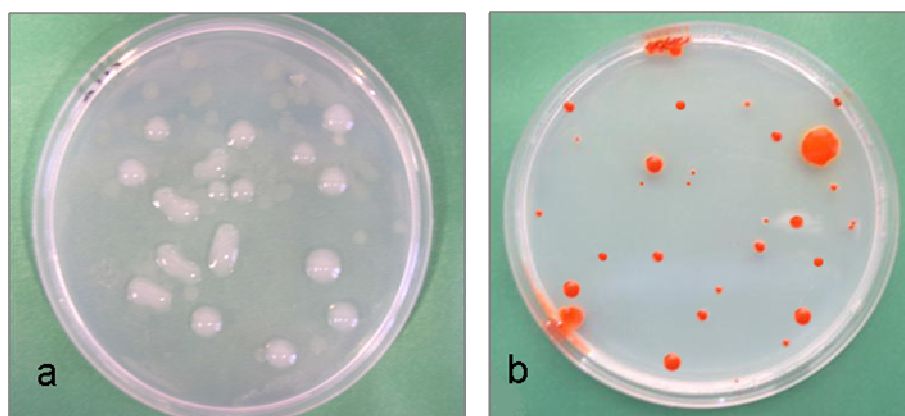

Figure 1 – Wild-type strain HCNT1 grown on YM agar (a) and on YM plus 25 mM selenite (b).

Unexpectedly, *nirK*-deficient strain HCAT2 did not grow on any of the selenite- containing media and the colonies did not turn red (Figure 2). This result suggests a possible involvement of nitrite reductase of HCNT1 strain in the reaction of selenite reduction and, as a consequence, in the resistance mechanisms to this anion.

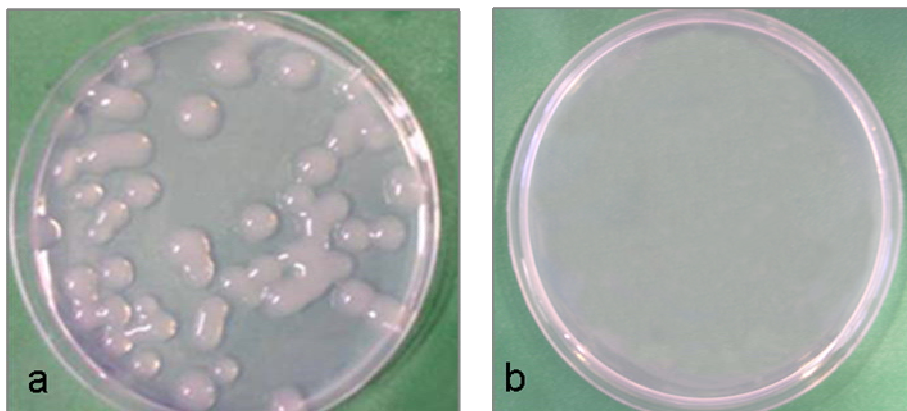

Figure 2 – *R. sllae* strain HCAT2 grown on YM (a) and in YM plus 25 mM of selenite (b).

To further investigate the role of Nir in selenite reduction, the capacity of *Rhizobium sllae* strain CC1335, a naturally *nirK* deficient strain, to grow in the presence of selenite was tested. Unlike HCNT1, this strain was unable to grow on media containing 25 or 50 mM Na_2SeO_3 (Figure 3), while on 5 mM Na_2SeO_3 the colonies showed a pale shade of red. This result clearly indicates that this strain is unable to reduce selenite to elemental less toxic selenium, becoming sensitive to this anion at concentration higher than 5 mM.

To determine whether *nirK* gene could allow growth on higher concentrations of selenite, the selenite resistance of CC1335/*nirK* was tested. CC1335/*nirK* is a strain that contains *nirK* from HCNT1 in *trans* and can reduce nitrite to nitric oxide (Toffanin *et al.*, 1996). Like the wild type HCNT1, strain CC1335/*nirK*⁺ grew on medium containing up to 50 mM Na_2SeO_3 . During the growth, the cells became red, indicating selenite reduction to Se^0 (Figure 3).

The result of these experiments seem to demonstrate that *nirK* is required for bacterial growth in the presence of high concentrations of selenite and confirm the hypothesis that nitrite reduction, in some microbial species, is related to selenite reduction.

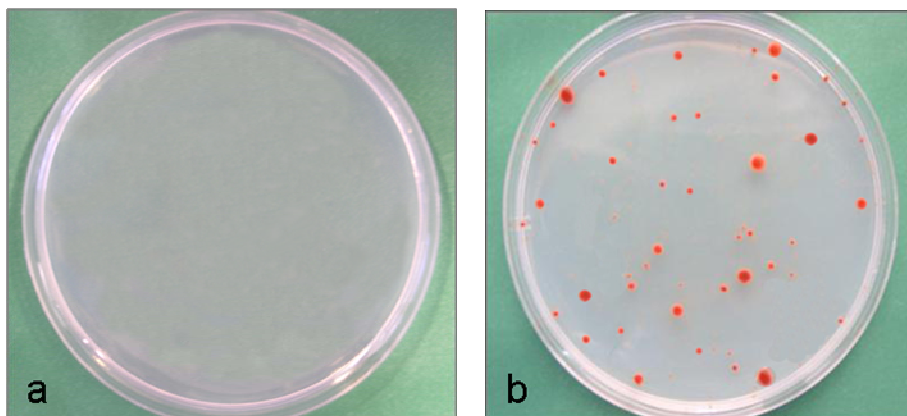

Figure 3 – Wild-type strain CC1335 (a) and its mutant *nirK*⁺ strain, CC1335/*nirK*, (b) grown in the presence of 25 mM selenite.

Growth of *Rhizobium sllae* in liquid culture with selenite

In order to verify if the nitrite reductase activity, associated to selenite reduction, was able to increase bacterial resistance to the toxic anion, strains HCNT1 and CC1335 of *R. sllae*, and the related mutants *nirK*⁻ and *nirK*⁺, respectively, were cultured in liquid medium with increasing concentrations of Na₂SeO₃. The results obtained are shown in Figures 4 and 5.

The presence of *nirK* seems to allow the cells to grow in gradually higher concentrations of selenite (5, 25 and 50 mM Na₂SeO₃), as shown by monitoring both colony forming units (CFU, Figure 4) and optical density (Figure 5) (Basaglia *et al.*, 2007).

Strain HCNT1 (Figures 4a and 5a), even though it reduces its growth rate with increasing concentrations of Na₂SeO₃, is able to produce biomass, also in the presence of 50 mM of selenite. During the growth, the cultures become red, indicating selenite reduction to elemental selenium (Figure 6).

Strain HCAT2 (Figures 4b and 5b), lacking *nirK* gene, is characterized by a limited growth in the presence of 5 mM of selenite, while it is not able to grow at higher concentrations. Moreover, after 24 hours of incubation, cellular culture does not become red, like the wild type (Figure 7). These evidences seem to confirm the hypothesis that nitrite reductase provides a mechanism of resistance to selenite.

Moreover, the data obtained for CC1335 and CC1335/*nirK*⁺ strains clearly reinforce the hypothesis that nitrite reductase of *R. sultae* has a key role in the mechanism of resistance to selenite.

The growth of wild-type strain CC1335, that lacks *nirK* gene, seems to behave like HCAT2, being able to growth only at lowest selenite concentration (5 mM) after a long lag-phase (Figures 4c and 5c), while its mutant strain CC1335/*nirK*⁺ acquired the ability to grow well even at 25 mM selenite (Figures 4d and 5d).

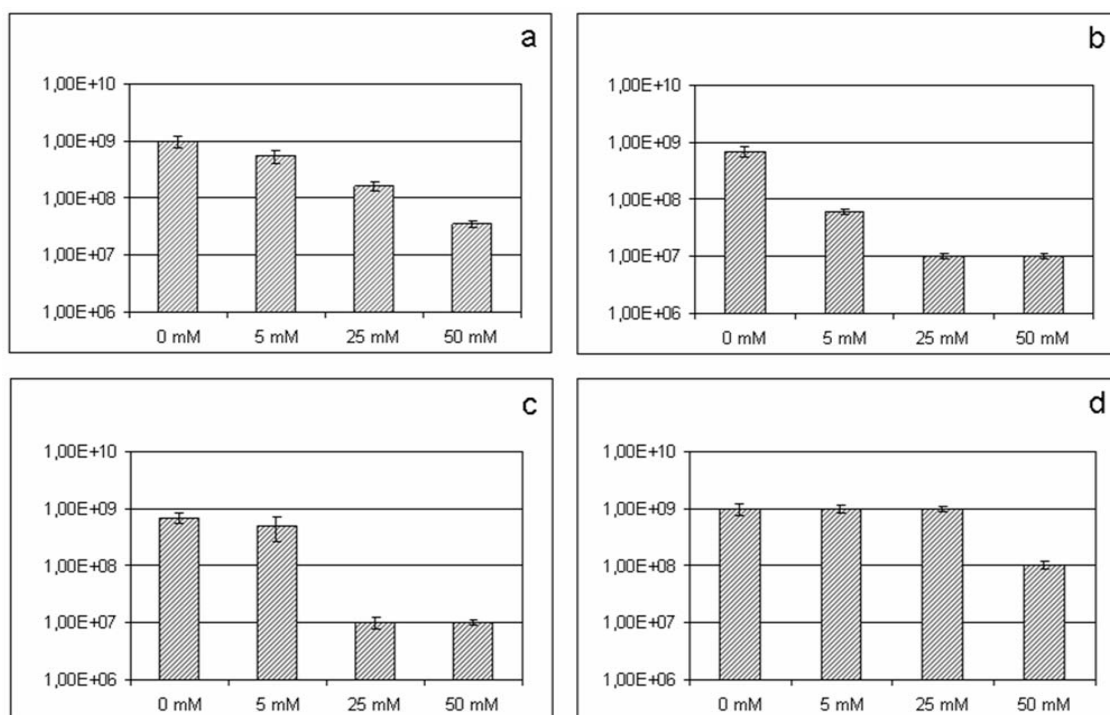

Figure 4 – Monitoring of colony forming units (CFU) in YM culture of HCNT1 (a), HCAT2 (b), CC1335 (c) and CC1335/*nirK* (d), after 72 hours of incubation in the presence of 0, 5, 25 and 50 mM selenite.

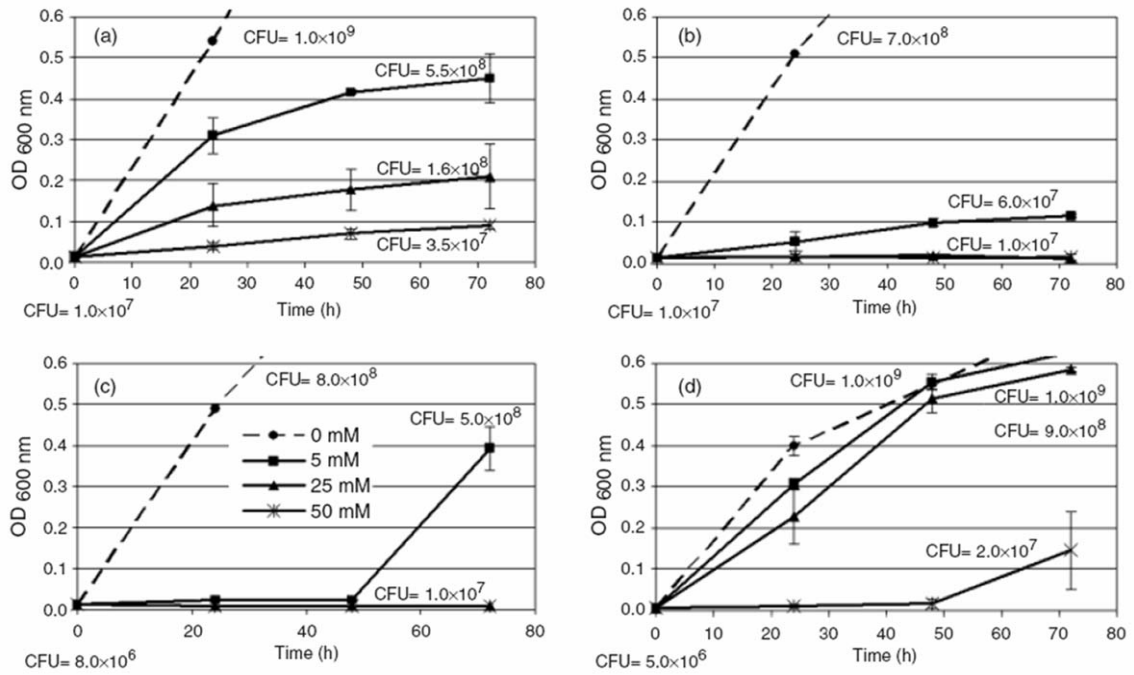

Figure 5 – Liquid culture of *Rhizobium sullae* strain HCNT1 (a), HCAT2 (b), CC1335 (c) and CC1335 *nirK*⁺ (d) in the presence of different concentrations of selenite. CFU are reported in the graphic at the start and the final time and represent the means of three replicates (Basaglia *et al.*, 2007).

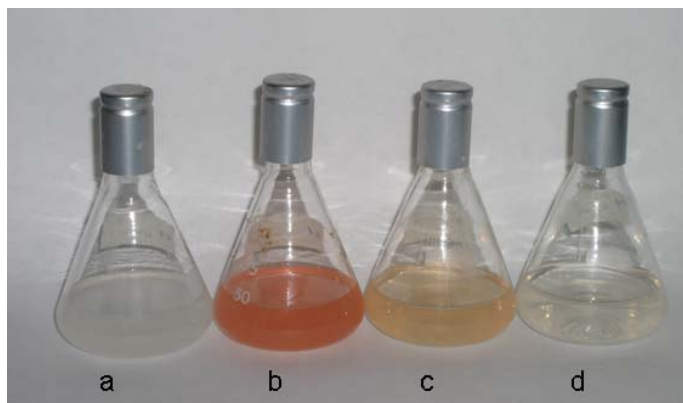

Figure 6 – Cellular cultures of *Rhizobium sllae* strain HCNT1 after 24 hours of incubation at different concentrations of Na_2SeO_3 : 0 mM (a); 5 mM (b); 25 mM (c); 50 mM (d).

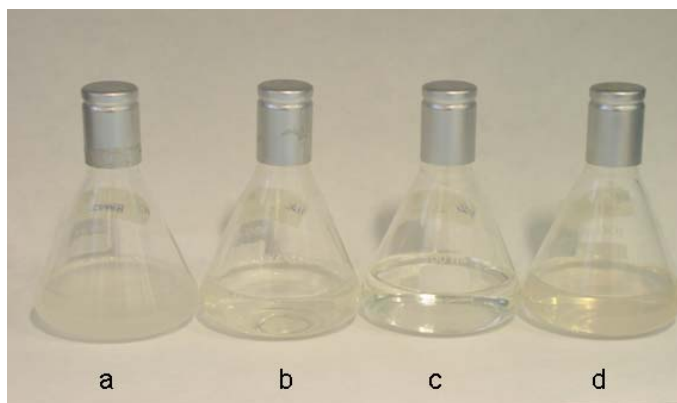

Figure 7 – Cellular cultures of *Rhizobium sllae* strain HCAT2 after 24 hours of incubation at different concentrations of Na_2SeO_3 : 0 mM (a); 5 mM (b); 25 mM (c); 50 mM (d).

Selenite reduction under different incubation conditions

Nitrite reduction to nitric oxide in HCNT1 occurs only after exposure of cells to oxygen-limited conditions. To verify whether incubation at low oxygen concentrations correlates with the ability to reduce selenite, microbial cells of HCNT1 and HCAT2 were incubated under different oxygen regimes and the reduction of 25 mM of selenite was recorded by the appearance of red colour.

When the bacteria were pre-incubated under low oxygen conditions, which will induce *nirK* expression, HCNT1 reduced selenite but HCAT2 did not (Table 1). Unexpected, cells of HCNT1 that were not exposed to low oxygen conditions were also able to reduce selenite. However, strain HCAT2 was unable to reduce selenite under any condition tested, indicating that the observed activity requires *nirK* expression.

Moreover, the selenite resistance phenotype requires a rich medium as cells incubated in saline media did not produce the red colour indicative of selenite reduction (Table 1).

Table 1 – Selenite reduction of strain HCNT1 and its *nirK* minus mutant strain HCAT2 under different incubation conditions

	After incubation under <i>nirK</i> inducing conditions	Aerobic culture
HCNT1		
Aerobic + YMB	+++	+++
Aerobic + saline	---	---
Anaerobic + YMB	+++	+++
Anaerobic + saline	---	---
HCAT2		
Aerobic + YMB	---	---
Aerobic + saline	---	---
Anaerobic + YMB	---	---
Anaerobic + saline	---	---

Evaluation of the constitutive selenite reductase activity in *Rhizobium sullae*

In *R. sullae* nitrite reduction occurs only after an incubation under oxygen limiting conditions.

To investigate whether selenite reductase was inducible, like nitrite reductase, or a constitutive enzyme, a series of experiments were performed using intact cells and a cell free system.

After aerobic growth in YM or TY broth without selenite, the culture of *R. sullae* HCNT1 was washed and resuspended in phosphate buffer saline at pH 8. In the presence of selenite (10 mM) either under aerobic or anaerobic atmosphere, the culture becomes red within 24 hours, indicating the reduction of selenite to elemental selenium (Figure 8: (a)1 and (a)2). However, using whole cells it was not possible to determine whether selenite reduction activity is really constitutive or not, since an induction may occur during the 24 hours incubation, hypothetically due to the presence of selenite itself. To elucidate this aspect, the same experiment was performed using cellular crude extract obtained from an aerobic culture lysate. When selenite was added to the supernatant of crude extract, it turned red (within 24 hours of incubation), both in aerobic and anaerobic atmosphere (Figure 8: (a)3 and (a)4), while in the same conditions the pellet did not show any selenite reductase activity (Figure 8: (a)5 and (a)6).

These results suggest that in this strain selenite reductase could be a constitutive enzyme, unlike the nitrite reductase.

This hypothesis was reinforced by similar results obtained by testing the mutant strain CC1335/*nirK*⁺ (Figure 8: (b)1-6).

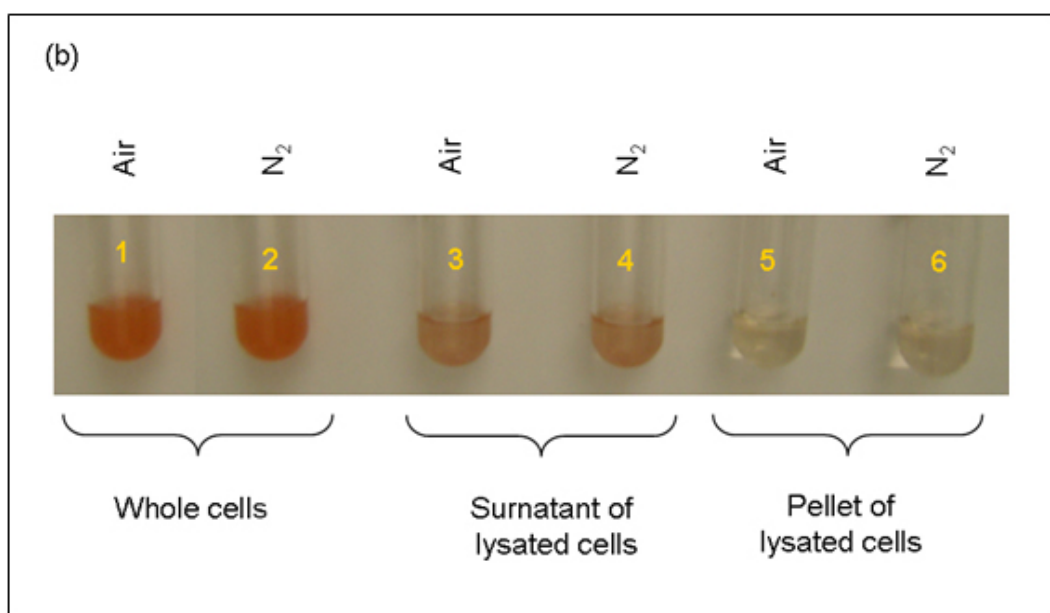
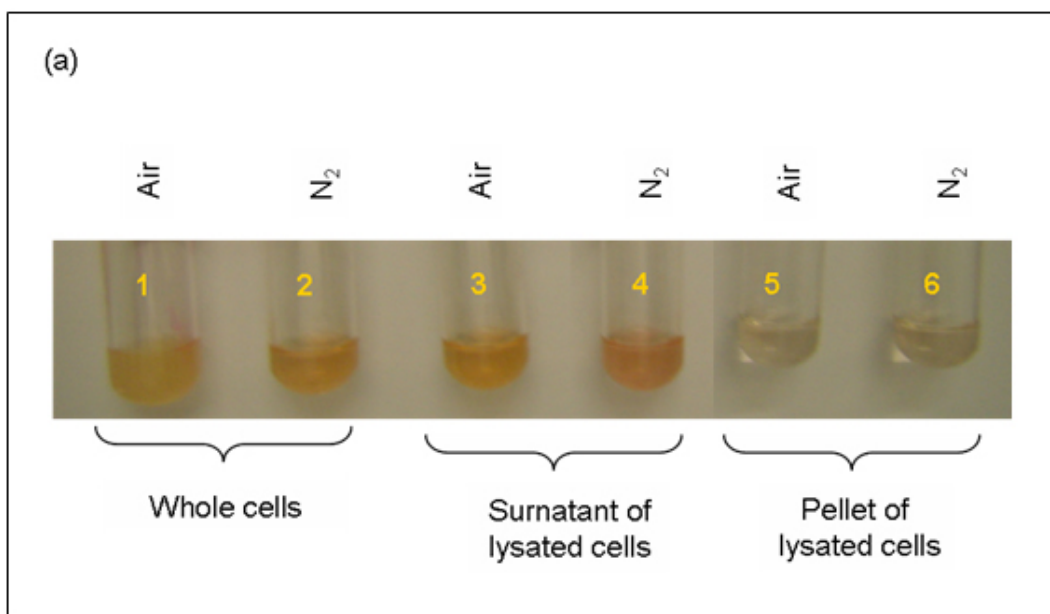

Figure 8 – *Rhizobium sultae* strain HCNT1 (a) and strain CC1335/*nirK*⁺ (b) resuspended in phosphate buffer, in the presence of 10 mM selenite, in aerobic and anaerobic atmosphere.

Effect of diethyldithiocarbamate (DDC) on selenite reduction activity

Diethyldithiocarbamate (DDC) has been shown to effectively inhibit the activity of copper-containing nitrite reductase by removal of copper from the assembled protein (Shapleigh and Payne, 1985; Casella *et al.*, 1988).

The use of this specific inhibitor of copper-containing nitrite reductase (10 mM) together with selenite (10 mM), results in the inhibition of selenite reductase activity, both on whole cells (Figure 9) and cell-free extract of strain HCNT1 and of the mutant strain CC1335/*nirK*⁺. In the presence of DDC cell cultures and the crude extracts do not become red, either under aerobic or microaerobic atmosphere.

These data suggest that in *Rhizobium sullae* the putative enzyme responsible for the reduction of selenite to elemental red selenium contains copper, like nitrite reductase enzyme, as it is inhibited by a copper chelator.

These evidences strengthen the hypothesis that nitrite and selenite reductase could be the same enzyme.

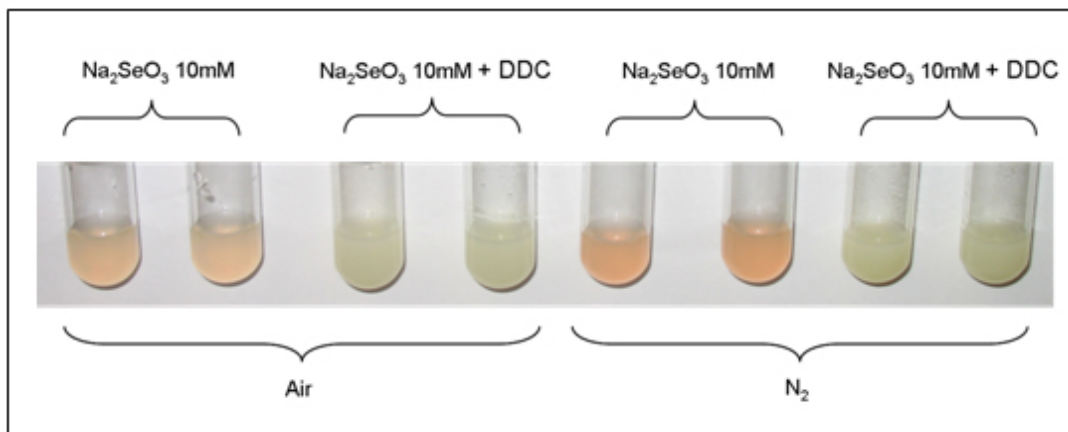

Figure 9 – *Rhizobium sullae* strain HCNT1 resuspended in phosphate buffer, in the presence of 10 mM selenite and 10 mM copper chelator diethyldithiocarbamate (DDC), in both aerobic and anaerobic atmosphere.

Regulation of *nirK* gene

To study in more detail the regulation of *nirK* expression in *R. sullivanii* HCNT1, the mutant strains HCAT4 (deriving from wild type strain HCNT1) and HCAT5 (deriving from *nirK*-minus strain HCAT2), containing the *nirK-lacZ* fusion cassette, were used.

Wild-type HCNT1 did not reveal any detectable β -galactosidase activity under any conditions used in this study, while all the mutant strains containing the *nirK-lacZ* fusion showed a base-line of β -galactosidase activity, even if cultured under aerobic conditions (Figure 10). However, the maximal levels of β -galactosidase activity occurred under microaerobic conditions, when the cells were grown in a flask sealed with rubber stopper to prevent oxygen exchange (Figure 10). In accordance with Casella *et al.* (1986) the presence of a nitrogen oxide was not required for *nirK* expression, but the pre-incubation under limited oxygen concentration strongly enhanced the transcription levels of *nirK*. The same effect did not occur when selenite was added to the aerobic culture, indicating that selenite has no effect on the expression level of *nirK* (Figure 10).

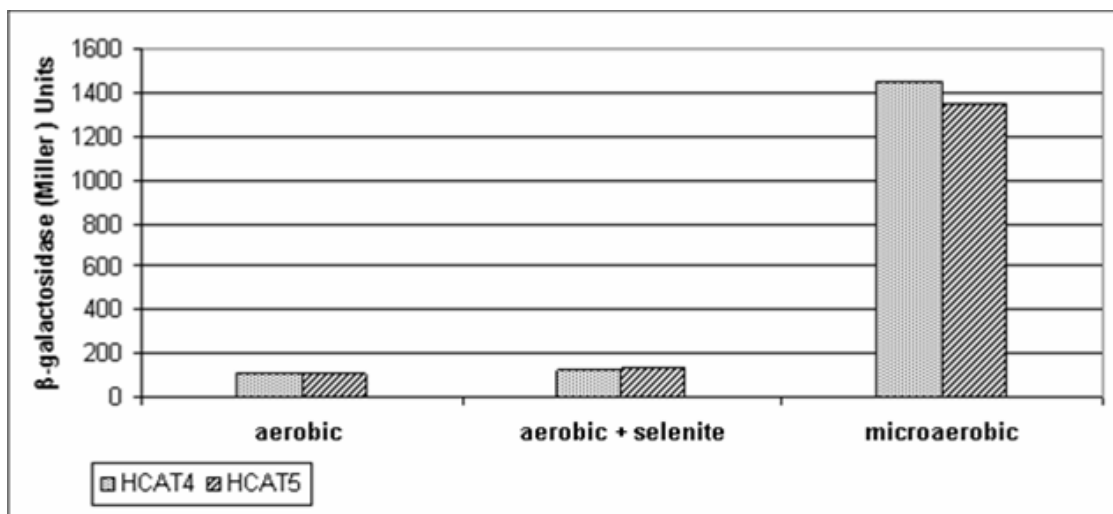

Figure 10 – Expression of *nirK-lacZ* in *Rhizobium sullivanii* strains HCAT4 and HCAT5 under various growth conditions.

mRNA extraction and cDNA synthesis

In order to validate the above observations, mRNA was extracted from cultures of HCNT1 strains, grown under aerobic and microaerobic conditions, and used to synthesize cDNA. As expected, the fragment obtained from RT-PCR, using primers *nirK1* (5') TCA TGG TGC TGC CGC GKG ACG G (3') and *nirK2* (5') GAA CTT GCC GGT KGC CCA GAC (3'), was of 326 bp. The obtained cDNA confirmed that *nirK* is always expressed, as the transcript is present either during aerobic or under microaerophilic conditions (Figure 11, lanes 1 and 2). Lane 3 represents a 16S transcript (positive control), used to test the efficiency of reverse transcription. To evaluate if genomic DNA was co-purified with RNA, in lanes 4 and 5 a PCR without reverse transcription was run and no bands were obtained.

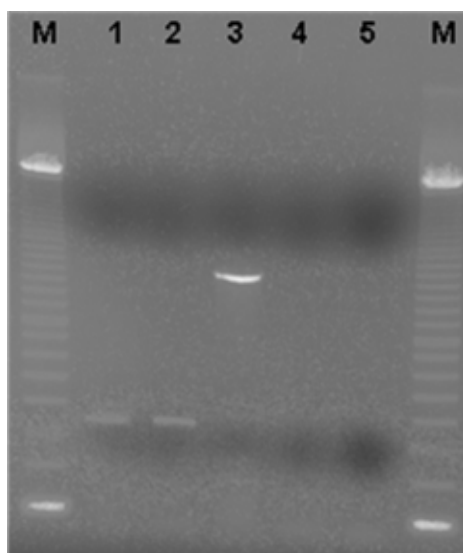

Figure 11 – Lane M: 100-bp markers; lane 1: RT-PCR with the primers designed for *nirK* of HCNT1, under aerobic conditions; lane 2: RT-PCR with the primers designed for *nirK* of HCNT1, under microaerobic conditions; line 3: RT-PCR with the primers designed for the 16S-rDNA of HCNT1, under aerobic conditions; lane 4: PCR without reverse transcriptase, carried out with the primers designed for *nirK* of HCNT1, grown in aerobic conditions; lane 5: PCR without reverse transcriptase, carried out with the primers designed for *nirK* of HCNT1, grown in microaerobic conditions.

Evaluation of nitrous oxide production

Cultures of wild-type strain, HCNT1, of its mutant, HCAT2 and of its complemented strain HCAT3 containing a plasmid carrying *nirK* gene, were cultured under microaerobic conditions for 48 hours. After the incubation, sodium nitrite (10 mM) was added in the sample at different times and the production of nitrous oxide was detected by gas-chromatography.

Increasing concentrations of nitrous oxide were accumulated in the headspace of the wild-type culture, revealing that *nirK* had been induced, while the mutant strain HCAT2, as expected, did not produce any protoxide during all tested times, since it lacks *nirK* gene. Strain HCAT3 showed a behaviour similar to that of HCNT1, but the amounts of protoxide produced were significantly higher than those produced by the wild-type strain (Figure 12). This difference is due to the presence of the *nirK* gene in multiple copies, carried by plasmid pRKAT7.

As expected, the aerobic culture of HCNT1 did not produce detectable amounts of nitrous oxide in the presence of nitrite, since *nirK* gene is not sufficiently induced to act as a nitrite reductase (data not shown).

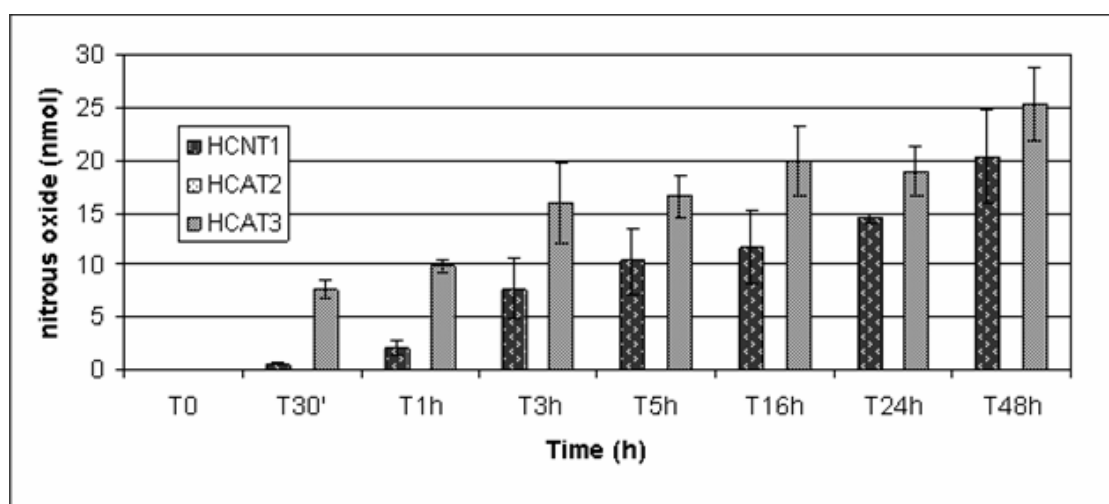

Figure 12 – Production of nitrous oxide by HCNT1, HCAT2 and HCAT3 strains, after incubation under low oxygen concentration. In each samples nitrite was added to a final concentration of 10 mM.

Effect of diethyldithiocarbamate (DDC) on nitric oxide production

Rizhobium sultae strain HCNT1 has been reported to contain a copper-type nitrite reductase on the basis that the copper chelator diethyldithiocarbamate (DDC) inhibited the overall process of denitrification (Casella *et al.*, 1988).

This specific inhibitor of copper-containing nitrite reductase also results in the inhibition of selenite reductase activity, both on whole cells and cell-free extract of strain HCNT1 and of the mutant strain CC1335/*nirK*⁺. These data suggest that the putative enzyme responsible for the reduction of selenite to elemental selenium contains copper, like nitrite reductase.

To test the real inhibition of nitrite reductase of HCNT1 in the presence of DDC, nitric oxide production was monitored by GC analyses (Figure 13). Incubation of cells with the copper-binding inhibitor diethyldithiocarbamate (1 and 10 mM) completely inhibited Nir activity, resulting in the loss of nitric oxide production at least within the first 16 hours.

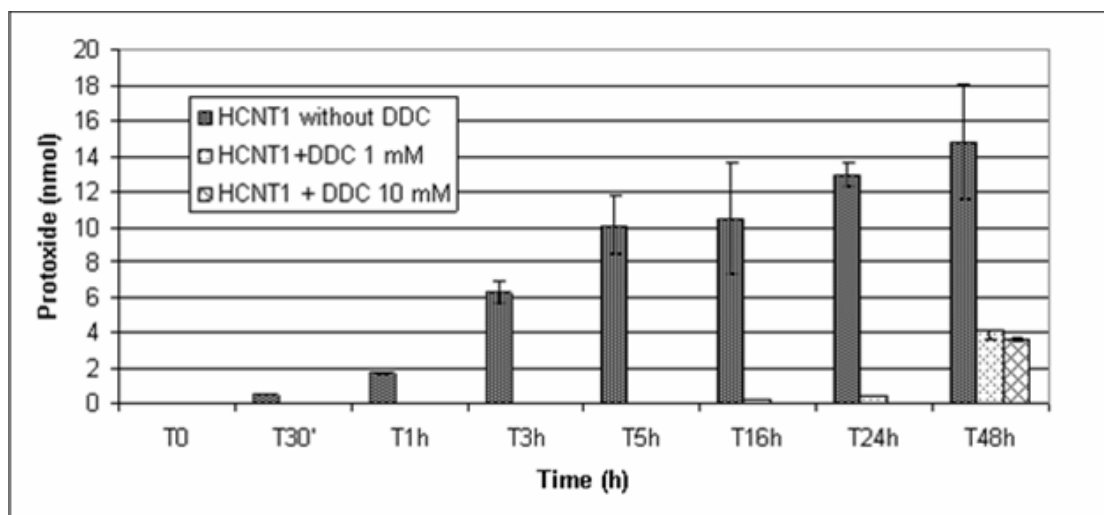

Figure 13 – Production of nitrous oxide by HCNT1 strain, after incubation under low oxygen concentration, with nitrite 10 mM, and with nitrite and different concentrations of DDC (1 and 10 mM).

Selenium deposits

Scanning electron microscope (SEM) examination revealed that granules, of about 0.25 μm diameter, were present in cultures of HCNT1 cells grown in the presence of Se oxyanions (Figure 14b), but, as expected, not in cultures of the *nirK*-deficient strain HCAT2 grown in the culture supplied with selenite (Figure 14d). Selenium deposits were found both in the media and associated with cells and were uniform in their size and appearance.

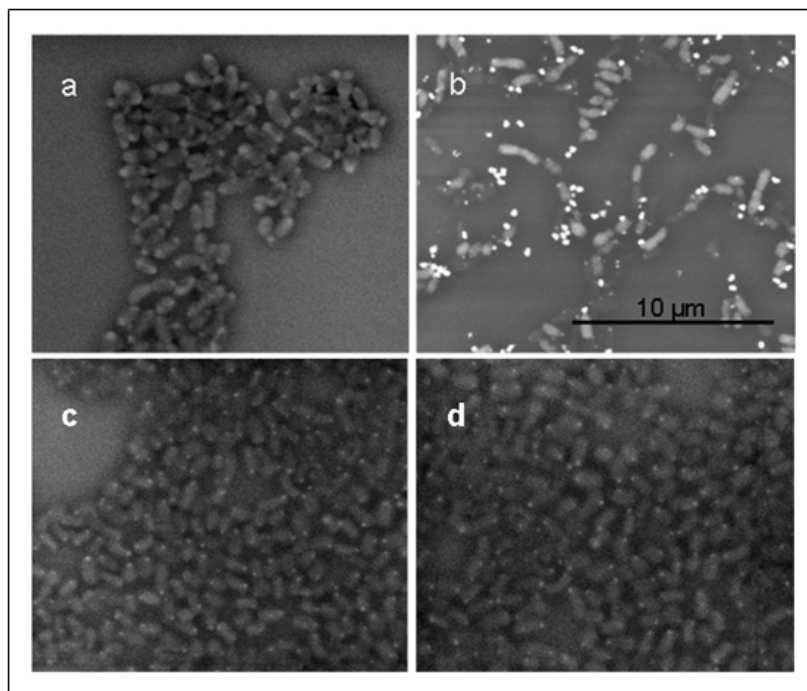

Figure 14 – SEM of HCNT1 (a and b) and HCAT2 (c and d) cultures grown in the absence (left) and in the presence (right) of 10 mM SeO_4^{2-} . Nanospheres of elemental red selenium appear as light spot both associated with the cells and free in the medium.

Choice of a suitable expression system for protein purification

In order to produce sufficient amounts of biomass and protein for purification purposes, *Escherichia coli* was chosen as a recipient. To express a protein of prokaryotic origin, *E. coli* is the obvious choice, since the method is quick and cheap and the microorganism has all the biological machinery necessary for folding and post-translational modifications. This would have been possible by cloning *nirK* in a plasmid and mobilizing it into *E. coli*. Unfortunately these bacteria show a significant selenite reductase activity by themselves (Turner *et al.*, 1998), making it difficult to select the active fraction. Cultures of *E. coli* became red in the presence of selenite (even with high concentrations), either in solid or in liquid medium, indicating the reduction of this oxyanion to the elemental selenium form (Fig. 15). Well grown liquid cultures produced the red colour only after 10 hours, revealing a high selenite-reductase activity. All laboratory strains of *E. coli* tested for selenite-reduction ability shown the presence of a mechanism for reducing selenite to elemental form, as indicated by the appearance of red colour. Therefore, an heterologous expression system able to produce recombinant proteins, in which specific affinity tags were added to the protein sequence of interest, was chosen.

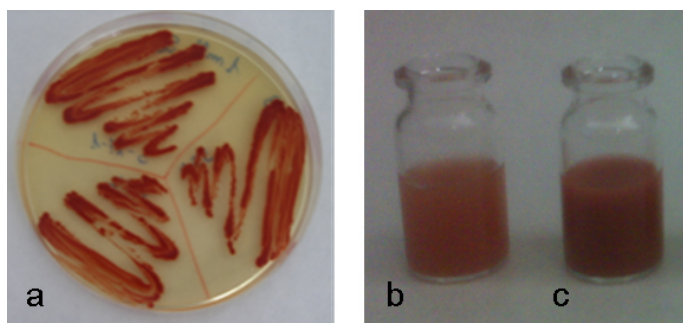

Figure 15 – Selenite-reductase activity in *E. coli* strain M15 (Qiagen) on LB agar (a) and in liquid culture (b) with 10 mM of selenite; (c) liquid culture of *R. sulae* HCNT1 in the presence of 10 mM of selenite.

Construction of the expression plasmid for Nir protein production

Plasmid pQE30 (QIAexpress system, Qiagen Inc.) is designed for high-level expression in *Escherichia coli* of proteins containing six consecutive histidine residues (6xHis affinity tag). The plasmid for overexpression of Nir protein containing an N-terminal 6xHis tag was obtained as follows.

A *Bam*HI-*Hind*III fragment containing the entire coding region of copper-nitrite reductase of *R. sultae* strain HCNT1 was amplified using primers *nirK* Fw (5'- GGA TCC ACA AAT ACA TTG CAA ATG ACC CGG -3') and *nirK* Rv (5'- AAG CTT GCT ACC CGA TGG CGA CCT -3') (Figure 16). The fragment, carrying restriction site *Bam*HI and *Hind*III, respectively, was isolated from agarose gel. Amplification product of 1145 bp was purified and cut with *Bam*HI and *Hind*III restriction enzymes to generate restriction sites that could be relevant for the following cloning procedures.

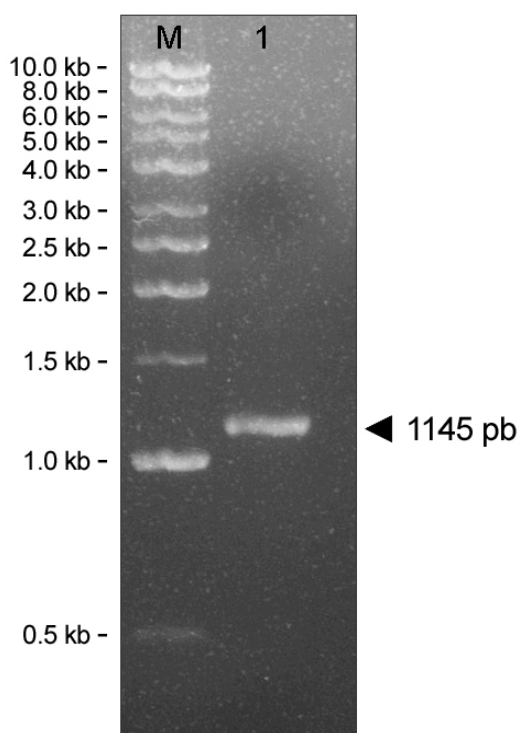

Figure 16 – Amplification of the coding region of *nirK* gene of *R. sultae* HCNT1. Lane M: 1kb DNA marker (GeneRuler™, Fermentas) lane 1: coding region amplicon of *nirK* gene.

This fragment was then ligated into the cloning vector pGEM-T (Promega). The ligation mixture was introduced into *E. coli* JM109 by electroporation. Transformants were selected by blue/white screening on Luria-Bertani agar supplemented with ampicillin and X-Gal/IPTG. White colonies, containing the insert of interest, were screened for the presence of *nirK* *Bam*HI-*Hind*III fragment (Figure 17).

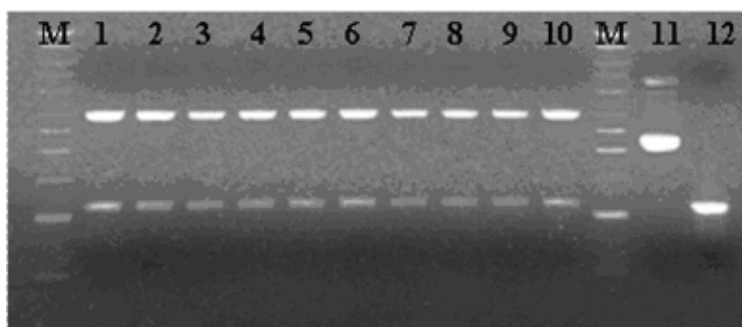

Figure 17 – Analysis of the transformants containing pGEM-T/*nirK* construct. Lane M: 1kb marker (GeneRuler™, Fermentas); lanes 1-10: digestion of pGEM-T with restriction enzymes *Bam*HI and *Hind*III from 10 different selected colonies; lane 11: pGEM-T plasmid; lane 12: amplification of *nirK* coding region with *nirK* Fw (5'- GGA TCC ACA AAT ACA TTG CAA ATG ACC CGG -3') and *nirK* Rv (5'- AAG CTT GCT ACC CGA TGG CGA CCT -3') primers.

The pGEM-T/*nirK* *Bam*HI-*Hind*III construct was subsequently digested with *Bam*HI and *Hind*III and the entire coding region of Nir was recovered and recloned into the expression plasmid pQE30, linearized with the same restriction enzymes, in appropriate molar ratio (1:3). The obtained pQE30/*nirK* *Bam*HI-*Hind*III construct was used to transform *E. coli* strain M15 with RbCl transformation method. Transformants were selected on Luria-Bertani agar supplemented with ampicillin and kanamycin for the presence of *nirK* by PCR analysis.

The structure of the resulting pQE-30/*nirK* expression plasmid was confirmed by restriction analysis of the plasmid DNA (Figure 18).

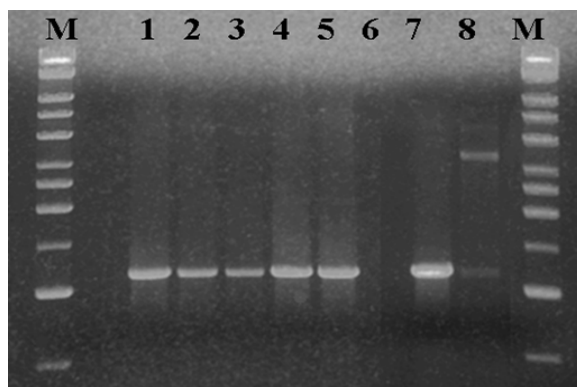

Figure 18 – Analysis of the transformants containing pQE-30/*nirK* construct. Lane M: 1kb marker (GeneRuler™, Fermentas); lanes 1-5: coding region of *nirK* gene; lane 6: negative control of PCR reaction; lane7: positive control, coding region of *nirK* gene amplified from chromosomal DNA of HCNT1; lane 8: restriction analysis with *Bam*HI and *Hind*III of pQE-30/*nirK* extracted from one of the selected colonies of *E. coli* M15.

Time-course analyses of protein expression

A time-course analyses is necessary to optimize the expression level of a given protein construct. Intracellular protein content is often a balance between the amount of soluble protein in the cells, the formation of inclusion bodies and protein degradation. The induction of protein expression in the present construct occurs when IPTG (isopropyl- β -D-thiogalactopyranoside) is added to the culture. By checking the 6xHis-tagged protein present at different times after its induction in the soluble and insoluble fractions, the optimal induction period can be established. After the addition of IPTG, aliquots of 1 mL of culture were removed at different times, lysed using 1x SDS-PAGE buffer and run on 12% SDS-polyacrilamide gel.

The results obtained are reported in Figure 19. The addition of IPTG into the culture caused clearly the induction of the expression of the recombinant protein, indicating the correct functioning of pQE-30/*nirK* expression construct in *E. coli* strain M15. Moreover, after only half an hour from the addition of IPTG, the protein of interest became clearly evident.

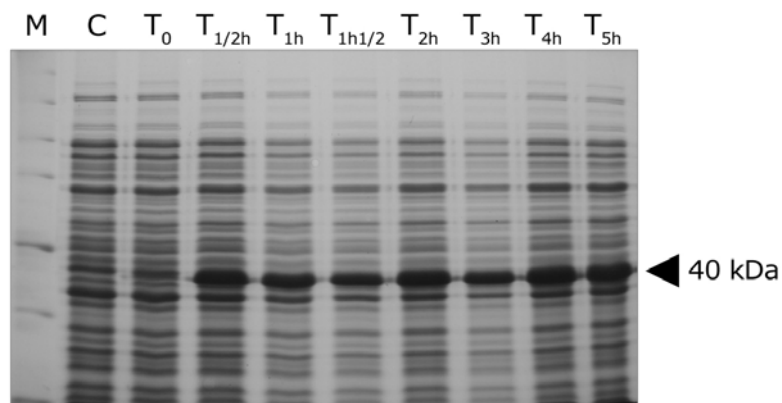

Figure 19 –Time course of expression of the recombinant protein in SDS-PAGE 12%.. M: markers (Protein standard, broad range, Bio-Rad); C: non-induced control (before the addition of IPTG); lanes T₀-T_{5h}: samples taken at different times during the growth of the induced culture. The gel was stained with Coomassie blue.

As expected, SDS-PAGE analysis revealed that 6xHis-tagged Nir was of about 40 kDa, most probably a monomer that forms the overall architecture of the homotrimeric enzyme. The coding region of *nirK* gene of *Rhizobium sulae* HCNT1, available in NCBI database, was processed by means of PyMOL (PyMOL, DeLano Scientific LLC), a molecular graphic system accessible from www.pymol.org. The output resulting structure (Figure 20) was similar to those copper-nitrite reductases previously reported (Cutruzzolà, 1999; Dodd *et al.*, 1998), a homotrimer of about 120 kDa, with three identical subunits of 40 kDa each, assembled in a characteristic triangular structure that has been resolved by X-ray diffraction analysis of the crystal (Dodd *et al.*, 1998; Godden *et al.*, 1991). The enzyme contains two Cu atoms per subunit molecule, which are distinguished from each other by their optical and electron paramagnetic resonance (EPR) spectroscopic properties (blue or green type 1 Cu centre and colourless type 2 Cu centre).

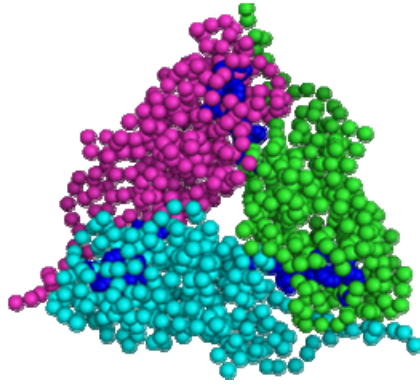

Figure 20 – Three-dimensional model for the copper nitrite reductase of *Rhizobium sulae*, obtained by using PyMOL molecular visualization system.

Determination of target protein solubility

Since the interaction between Ni-NTA resin, provided by The QIAexpressionist™ kit, and the 6xHis-tag of recombinant protein do not depend on tertiary structure, protein can be purified either under native or denaturing conditions. To set up the best purification strategy, it is important to determine whether the protein is soluble in the cytoplasm or located in cytoplasmic inclusion bodies.

To establish the target protein solubility, samples taken at different times after the addition of IPTG to the culture, were resuspended in lysis buffer containing imidazole (50 mM NaH₂PO₄, 300 mM NaCl, 10 mM imidazole; pH 8.0), suitable for the purification of protein under native conditions, lysed with a disruptor cell and centrifuged to separate soluble from insoluble fractions. Each fraction was analysed by SDS-PAGE.

The recombinant Nir-protein was found in the insoluble fraction (Figure 21, lanes 6 and 8) and, as above, its molecular weight resulted as about 40 kDa.

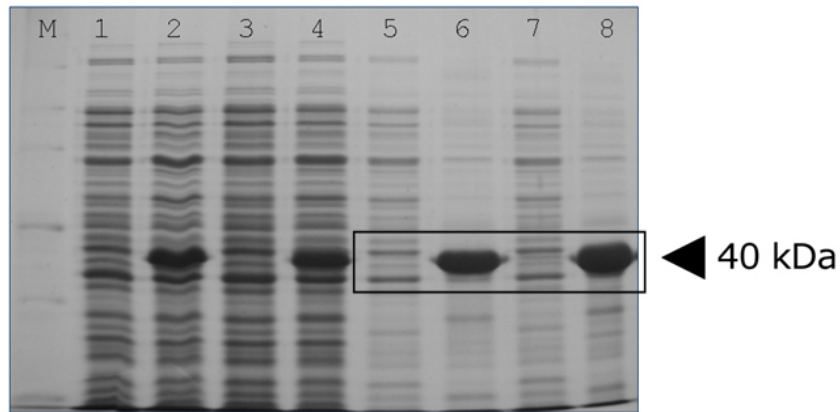

Figure 21 –Determination of the target protein solubility on SDS-PAGE 12%. M: marker (Protein standard, broad range, Bio-Rad); lanes 1 and 3: non-induced cells; lanes 2 and 4: induced cells with IPTG; lane 5 and 7: soluble fraction of crude extract of the cells; lanes 6 and 8: insoluble fraction of crude extract of the cells.

When the protein of interest is found in the insoluble fraction, it is critical to ensure that the cells are completely lysed. If the protein remains insoluble, the pellet could be extracted with 0.25% of Tween20 and 0.1 mM EGTA a few times in order to separate the protein possibly associated with the membrane fragments in the cell pellet.

In the present case, even after a second treatment with the above detergents, the recombinant protein was still found in the insoluble fraction (Figure 22a, lanes 2 and 4).

Moreover, the complete lysis of the induced cells was controlled through another two disruption cycles at 1.5 Kbar and 2.0 Kbar (Figure 22b). SDS-PAGE analysis revealed that the protein was still in the insoluble material (Figure 22b, lane 2).

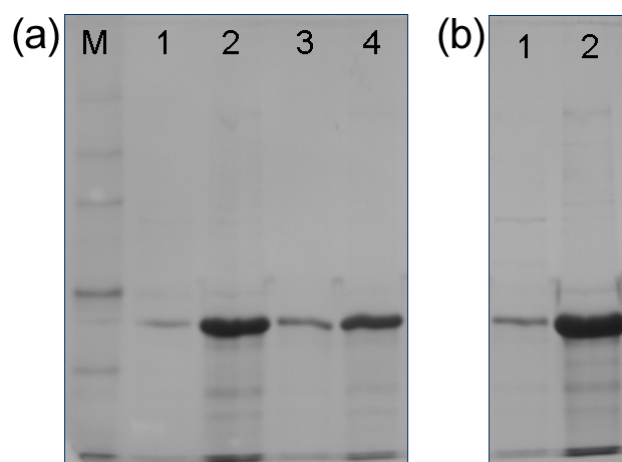

Figure 22 – SDS-PAGE 12%. (a) Extraction of insoluble recombinant protein with 0.25% Tween20 and EGTA. Lane M: marker (Protein standard, broad range, Bio-Rad); lanes 1 and 3: soluble fraction; lanes 2 and 4: insoluble fraction. (b) Cells further treated with Cell Disruptor, using two cycles of higher pressure (1.5 and 2 Kbar). Lane 1: surnatant of crude extract; lane 2: pellet of crude extract.

In a variety of expression systems for recombinant proteins, high levels of expression can lead to the formation of insoluble aggregates in the cytoplasm, known in *E. coli* as inclusion bodies. Many proteins can form inclusion bodies, while others are tolerated well by the cell and remain in the cytoplasm in their native configuration.

The procedure for purifying this protein was undertaken under denaturing conditions, using strong denaturants such as 6 M GuHCl or 8 M urea that completely solubilize cytoplasmic bodies and 6xHis-tagged proteins.

Overproduction and batch purification of Nir protein

The amount of culture required depends upon the level at which the protein is expressed. Overproduced recombinant Nir protein was found to be located into insoluble fractions, most probably in the mentioned cytoplasmic inclusion bodies. Therefore, the protein of interest was purified under denaturing conditions, using urea (8 M) as denaturing agent, with the aid of Ni-NTA (nickel-nitrilotriacetic acid) resin, in a batch system, by following protocols of The QIAexpressionist™ kit. This strategy is based on the high-affinity binding of six consecutive histidine residues (the 6xHis tag) to immobilized nickel ions, giving a highly selective interaction that allows purification of tagged proteins and promotes efficient binding of the protein especially when 6xHis tag is not fully accessible. The batch procedure entails binding the protein to the Ni-NTA resin in solution and then packing the protein-resin complex into a column for the washing and elution steps. Elution of the tagged protein was achieved by reducing the pH of the elution buffer from 5.9 to 4.5.

All collected fractions were loaded on a 12% SDS-PAGE gel.

Monomers of 6xHis-tagged protein generally elute in buffer with pH 5.9 (Figure 23a, lanes 1, 2, 3, 4), while multimers and aggregates of the recombinant protein generally elute in buffer with pH 4.5 (Figure 23b, lanes 1, 2, 3, 4).

All of these polypeptides appear to be induced following addition of IPTG which suggests that they are products of *nirK* gene. Furthermore, the polypeptides most likely contain the 6xHis tag and the intact N-terminus, because they bind to the nickel-nitrilotriacetyl resin.

The recovery rates of protein purification was established by spectrophotometer. The yield of monomers of recombinant Nir was about 6 mg protein per litre cell culture, while the yield of the multimers and the aggregates of monomers was about 90 mg protein per litre cell culture.

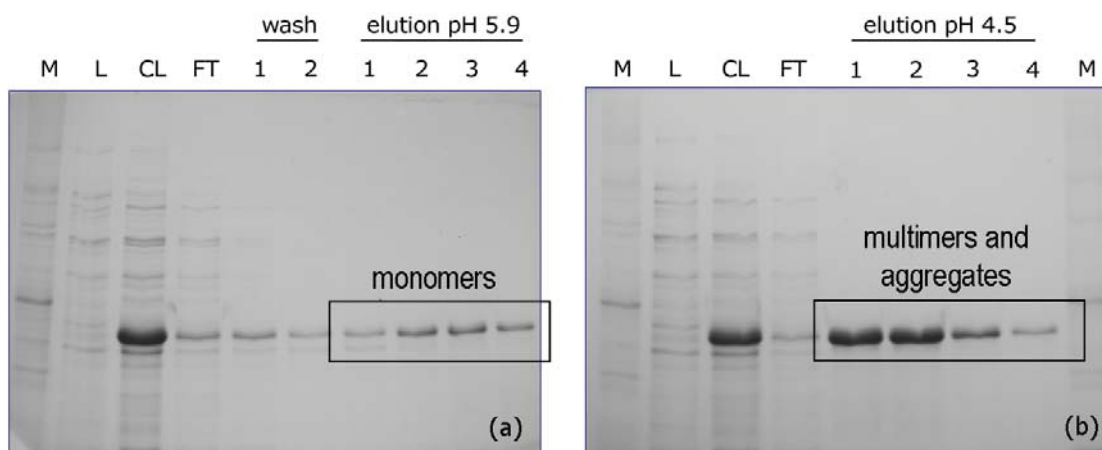

Figure 23 – Purification under denaturing conditions, with Ni-NTA column. Lane M: markers (Protein standard, broad range, Bio-Rad); lane L: crude extract of non-induced culture; lane CL: cell lysate; lane FT: flow-through. Proteins were visualized by Coomassie staining.

***In vitro* assay for nitrite and selenite reduction activity**

In order to solubilize inclusion bodies, containing recombinant 6xHis-tagged proteins, Nir protein was purified under strongly denaturing conditions. This was possible since purification process used in these experiments, based on the binding affinity between Ni-NTA matrix and 6xHis tags, was independent of tertiary structure of the tag itself.

However, for testing *in vitro* nitrite and selenite reduction ability it is necessary to renature the recombinant protein.

The collected fractions containing 6xHis-tagged protein, monomers or aggregates of monomers, were dialysed overnight against ice-cold PBS, to remove urea, and used to undertake preliminary *in vitro* experiments for evaluating nitrite and selenite reduction ability, separately.

Stewart and Parales assay (1998), described in Materials and Methods, that estimates the disappearance of nitrite, was used to test the ability of the purified protein to reduce this

nitrogen oxyanion. In all the collected fractions, monomers and aggregates, nitrite was added in two different amounts (50 μmol and 500 μmol). Each experiment was made with 5 mg of purified protein under anaerobic conditions in the presence of methylviologen, as an electron donor, and after a treatment with CuCl_2 that promote the assembling of the single subunits in the working homotrimeric structure. The purified protein showed the capacity to reduce nitrite in all the above conditions tested after 30 minutes. Preliminary results, shown in Figure 24, seem to reveal that there are no significant differences on reduction ability between monomers and aggregates.

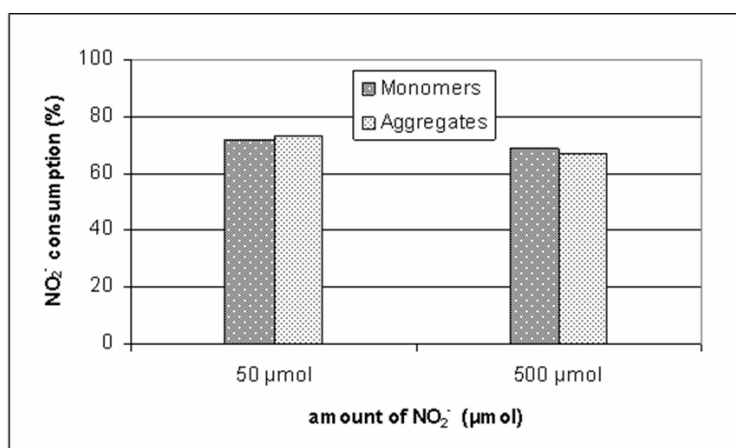

Figure 24 – Nitrite reduction activity of the purified protein (monomers and aggregates), evaluated as the consumption of nitrite.

Selenite reduction activity was tested by assembling the subunits in the same way adopted for nitrite reduction assays. Selenite was added at different amounts (50 μmol and 500 μmol) to monomers and aggregates, in the presence of methylviologen.

Unexpectedly, selenite reduction did not occur under the conditions used for nitrite-reduction assay. This result seems to contrast with all the evidences reported so far that clearly indicated Nir as responsible of both nitrite and selenite reduction. However, for acting as selenite reductase the purified protein could likely work as a monomer, rather than

a trimer, and it was clearly shown that the enzyme can better reduce selenium oxyanion in aerobic conditions. Furthermore, while the reduction of nitrite to nitric oxide requires one electron, the reduction of selenite to elemental selenium needs four electrons. Finally, recombinant Nir could be only partially refolded and less active, or could require some key co-factors present in the cell and absent *in vitro*.

For all these reasons, to investigate on the optimal conditions this enzyme would be able to excellently perform, will likely require time and particular care . These latest experiments, indeed, represent a first approach inside a working plan aiming at studying the purified protein into details. Therefore, the determination of culture conditions preventing inclusion bodies formation and the improvement of purification methods, protein stability studies, selenite-nitrite interference with the purified protein, together with the assessment of optimal selenite reduction conditions, are all investigations to be done in the near future.

Conclusions

Rhizobium sullae was isolated from root nodules of a forage legume, *Hedysarum coronarium* L., French honeysuckle.

Previous studies have shown the peculiarity of this strain, in that it has only one of the four reductases required for the complete denitrification pathway.

Strain HCNT1 does not obtain any obvious benefits from its radically truncated denitrification chain (Casella *et al.*, 2006), so the conservation of the unique gene of denitrification that encodes for a dissimilatory nitrite reductase is apparently inexplicable.

Nitrite reductase enzyme of HCNT1 is encoded by *nirK* gene and is closely related to nitric oxide (NO)-generating nitrite reductases in true denitrifiers, showing a 65 to 80% identity with other Nir proteins.

R. sullae is atypical among related denitrifiers, as the expression of the *nirK* gene does not require the presence of the substrate (nitrogen oxide), but only requires a decrease in oxygen concentration (below 16.5% of air saturation). The reduction of nitrite to nitric oxide is carried out by microbial cells only after induction of *nirK* under microaerobic conditions (Toffanin *et al.*, 2000). Concerning the enzyme activity, *R. sullae* does not seem to attain any bioenergetic benefits, since during nitrite reduction to nitric oxide no proton translocation occurs. Moreover, by considering that the produced nitric oxide binds to the terminal oxidases, thus inhibiting aerobic respiration, nitrite reduction seems to become a self-destroying process preventing microbial cell from energy conservation.

Although nitrite reductase expression is not disadvantageous for HCNT1, as *nirK* gene is conserved inside the genus, it is still unclear if this trait could provide any benefit. Inactivation of *nirK* resulted in no obvious phenotypic changes in HCNT1, other than those linked to the loss of NO production. Strains of *R. sullae* that lack nitrite reductase have been isolated (such as CC1335 strain), and they nodulate *Hedysarum* spp. as effectively as HCNT1, indicating that nitrite reductase is not required for infection and nodulation (Casella *et al.*, 1984). For these reasons the meaning of the presence of this conserved gene has to be investigated directly on rhizobia as free-living organism, rather than a symbiotic one. In this direction a lot of work has been done in the last few years.

For instance, the presence and the expression of nitrite reductase has been hypothesized as a bacterial strategy to reduce their own energetic content, inducing a deep dormancy status. With regard to that, some evidences seem to relate Nir activity to VBNC (viable but not cultivable) status (Basaglia *et al.*, 2007).

Results obtained in this work allowed investigating in depth the specific role of *nirK* gene in the metabolism of *R. sultae*.

In different strains of *R. sultae*, containing *nirK*, it was possible to underline the concomitance of Nir activity with the reduction of selenite (Na_2SeO_3) to elemental selenium (Se^0). This evidence was not found in strains that lack nitrite reductase gene, where the ability to reduce selenium oxyanions was tightly diminished or absent.

Moreover, the mobilization of *nirK* gene into wild type CC1335, a naturally occurring nitrite reductase deficient strain, resulted in a phenotype similar to that of HCNT1: under anoxic incubation it can reduce nitrite, there is no anaerobic growth and it acquired the ability to reduce selenite.

In order to verify whether Nir activity increases resistance of microbial cells to this toxic oxyanion, in addition to its own ability to reduce selenite to red elemental form, strains HCNT1 and CC1335 and their respective mutants, HCAT2 and CC1335/*nirK*⁺, were grown in liquid culture with increasing concentrations of Na_2SeO_3 . The data obtained in these experiments allowed assigning to nitrite reductase enzyme a key role in the mechanisms of resistance to selenite. The presence of *nirK* gene confers the ability to grow at high concentrations of selenite, such as 25 or 50 mM Na_2SeO_3 .

In this respect the activity of Nir could confer an evolutionary advantage to microbial cell, providing a mechanism of tolerance to selenite, the most dangerous form of selenium present in terrestrial ecosystem for living organism. In effect, *R. sultae* strain HCNT1 was isolated from a soil containing moderately high concentrations of selenium ($1 < [\text{Se}] < 2$ mg/kg dry weight): the levels of total selenium, found in this soil, slightly exceed the threshold values for the classification of a selenifer soil (Casalicchio, 2000). Considering that strain HCNT1 does not seem to obtain any energetic advantage maintaining or acquiring the truncated denitrification chain (Casella *et al.*, 2006), it is possible to conclude that this trait was specifically selected in a habitat where these bacteria evolved. The ability

to diminish the presence of selenite in the soil gives to the studied strains an evolutionary advantage in a soil characterized by high content of selenium.

The persistence of Nir in *R. sultae*, despite the absence of Nor, along with its novel regulation, suggests that bacteria in this environment may encounter microsites where selenium concentrations are high enough to require an additional level of resistance. This would explain why Nir is conserved in bacteria living in these soils and represents a novel use of this enzyme.

The experiments undertaken in this work had the aim to better study the nitrite reductase activity of *R. sultae* in different environmental conditions, in the presence of nitrite, selenite or both. In this approach it was possible to clarify if nitrite reductase and selenite reductase, in *R. sultae*, are the same protein that works in different way, according to the substrate (nitrite or selenite) and to the atmospheric conditions, or two distinct proteins that work independently. First of all, it was observed that selenite reduction activity occurred either under aerobic or anaerobic atmosphere, while the reduction of nitrite to NO can be attained only after a preincubation under microaerobic conditions, and that the presence of nitrite in the cultural medium together with selenite did not influence selenite reduction to elemental red selenium. On the contrary, the addition of selenite to cultures containing nitrite inhibits the production of nitrogen oxides. Moreover, the use of a specific chelator of copper-containing nitrite reductases (diethyldithiocarbamate) together with selenite in the culture, inhibited also the reduction of this oxyanion to elemental red form. This latest result means that the putative selenite reductase in *R. sultae* contains copper, like nitrite reductase. Many assembled evidences seem to suggest that nitrite and selenite reductase could be the same protein; in other words, the enzyme studied could be a selenite reductase, rather than a nitrite reductase, which reduce selenite under aerobic condition and that becomes able to reduce also nitrite but only after a treatment under microaerobic condition.

To answer this question, an appropriate strategy for the production of suitable amounts of the protein to be subsequently purified, was undertaken and mutant strains and the recombinant Nir protein were obtained. Initially, for these purposes, *E. coli* was chosen as possible recipient, since it represents a cheap and quick system for protein expression. Unfortunately, these bacteria showed a considerable selenite reductase activity by themselves (Turner *et al.*, 1998), so an approach based on the use of recombinant proteins,

where the protein of interest was fused with six consecutive histidine residues (6xHis-tag), was chosen. SDS-polyacrylamide gel analyses revealed that the purified protein, encoded by *nirK* gene, was of about 40 kDa that is a subunit which form the overall architecture of the homotrimeric enzyme (120 kDa).

Before producing the required amount of recombinant protein for purification purposes, and before characterizing it with X-ray crystallography, the first fraction of the purified Nir protein was used, first of all, to undertake preliminary *in vitro* experiments for testing its ability to reduce nitrite and selenite separately. Although Nir protein has shown the capacity to reduce nitrite, the optimal conditions in which the protein could reduce selenite are still to be investigated.

Thanks to a lot of evidences collected in previous studies and in this work, we can assert that nitrite and selenite reductase activities could be, most likely, imputable to the same enzymatic protein.

The present work, therefore, has evidenced the role of *nirK* gene in the reduction of selenite, supposing its involvement in the mechanisms of tolerance to this oxyanion in *R. sullae* HCNT1. The possible competitive advantage deriving from Nir activity in strains isolated from selenifer soils could even positively affect the symbiosis with the specific host plant, *H. coronarium*, allowing nodulation in adverse environmental conditions.

These results, even if not definitive, represent an important starting point to carry out further studies aimed at (a) unambiguously figure out the multifunction of a known enzyme such as the bacterial Cu-containing nitrite reductase, (b) understanding the way the enzyme is able to shift from a substrate (nitrite) to another (selenite), (c) evaluating the ability of Nir to reduce other oxyanions different from nitrite and selenite, (d) clarifying the possible role of the enzyme in the plant-microorganism (*R. sullae*-*H. coronarium*) symbiosis in terms of root nodulation and nitrogen fixation.

Acknowledgements

This work is part of EU-COST Action 856. I gratefully acknowledge Annita Toffanin for providing genetically modified strains. I would also like to thank Silvana Povolo for the support in molecular biology and Federico Fontana for skillful technical advice.

References

- Adman, E.T. (1991) Copper protein structures. *Adv Protein Chem* 42: 145-197.
- Adman, E.T., Godden, J.W., Turley, S. (1995) The structure of copper-nitrite reductase from *Achromobacter cycloclastes* at five pH value, with NO_2^- bound and with type II copper depleted. *J Biol Chem* 270: 27458-27474.
- Anders, H.J., Kaetzke, A., Kämpfer, P., Ludwig, W., Fuchs, G. (1995) Taxonomic position of aromatic-degrading denitrifying pseudomonad strains K 172 and KB 740 and their description as a new members of the genera *Thauera*, as *Thauera aromatica* sp. nov., and *Azoarcu*, as *Azoarcus evansii* sp. nov., respectively, members of the beta subclass of the *Proteobacteria*. *Int J Syst Bacteriol* 45: 327-333.
- Basaglia, M., Toffanin, A., Corich, V., Vian, P., Concheri, G., Giacomini, A., Squartini, A., Nuti, M.P., Casella, S. (1997) in IMPACT 2 Contractors meeting, Granada, Spain, pp.19-20.
- Basaglia, M., Toffanin, A., Shapleigh, J.P., Baldan, E., Casella, S. (2004) Elucidating the cause and the effect of NO accumulation in *R. sultae* strain HCNT1. Cost Action 856: Ecological Aspects of Denitrification with Emphasis on Agriculture. March 25th- 28th (pp.56), Marburg, Germany.
- Basaglia, M., Toffanin, A., Baldan, E., Bottegal, M., Shapleigh, J.P., Casella, S. (2007) Selenite-reducing capacity of the copper- containing nitrite reductase of *Rhizobium sultae*. *FEMS Microbiol Lett* 269(1): 124-130.
- Basaglia, M., Povolo, S., Casella, S. (2007) Resuscitation of viable but not culturable *Sinirrhizobium meliloti* 41 pRP4-*luc*: effect of oxygen and host plant. *Curr Microbiol* 54(3): 167-174.

- Bazylinski, D.A., Blakemore, R.P. (1983) Denitrification and assimilatory nitrate reduction in *Aquaspirillum magnetotacticum*. *Appl Environ Microbiol* 46: 1118-1124.
- Berendes, F., Gottschalk, G., Heine-Dobbernack, E., Moore, E.R.B., Tindall, B.J. (1996) *Halomonas desiderata* sp. nov., a new alkaliphilic halotolerant and denitrifying bacterium isolated from a municipal sewage works. *Syst Appl Microbiol* 19: 158-167.
- Berks, B.C., Richardson, D.J., Ferguson S.J. (1993) Purification and characterization of a nitrous oxide reductase from *Thiosphaera pantotropha*. Implication for the mechanism of aerobic nitrous oxide reduction. *Europ J Biochem* 212: 467-476.
- Berks, B.C., Ferguson S.J., Moir J.W.B., Richardson D.J. (1995) Enzymes and associated electron transport systems that catalyse the respiratory reduction of nitrogen oxides and oxyanions. *Biochem Biophys Acta* 1232: 97-173.
- Bogossian, G.L.E., Sammons, P.J.L., Morris, J.P., O'Neil, M.A., Heitkamp, M.A., Weber, D.B. (1996) Death of the *Escherichia coli* K-12 strain W3110 in soil and water. *Appl Environ Microbiol* 62: 4114-4120.
- Bradford, M.M. (1976) A rapid and sensitive method for the quantitation of microgram quantities of protein utilizing the principle of protein-dye binding. *Anal Biochem* 72: 248-252.
- Brown, G.C. (1995) Nitric oxide regulates mitochondrial respiration and cell functions by inhibiting cytochrome oxidase. *FEBS Lett* 369: 136-139.
- Callaham, D. A., Torrey, J.G. (1981) The structural basis for infection of root hairs of *Trifolium repens* by *Rhizobium*. *Can J Bot* 59:1647-1664.

- Casella, S., Gault, R.R., Reynolds, K.C., Dyson, J.R., Brockwell, J. (1984) Nodulation studies on legume exotic to Australia: *Hedysarum coronarium* L. *FEMS Microbiol Letters* 22:37-45.
- Casella, S., Shapleigh, J.P., Payne, W.J. (1986) Nitrite reduction in *Rhizobium* "hedysari" strain HCNT1. *Arch Microbiol* 146: 233-238.
- Casella, S., Shapleigh, J.P., Lupi, F., Payne, W.J. (1988) Nitrite reductase in bacteroids of *Rhizobium* "hedysari" strain HCNT1. *Arch Microbiol* 149: 384-388.
- Casella, S., Fontana, F., Povoio, S., Basaglia, M. (2001) in ISME-9, 9th International Symposium on Microbial Ecology, Amsterdam, The Netherlands, p.191.
- Casella, S., Shapleigh, J.P., Toffanin, A., Basaglia, M. (2006) Investigation into the role of the truncated denitrification chain in *R. sulae* strain HCNT1. *Biochem Soc Trans* 34(1): 130-132.
- Cassab, G. I. (1998) Plant cell wall proteins. *Annu Rev Plant Physiol Plant Mol Biol* 49: 281-309.
- Causey, M.B., Beane, K.N., Wolf, J.R. (2006) The effects of salinity and other factors on nitrite reduction by *Ochrobactrum anthropi* 49187. *J Basic Microbiol* 46(1): 10-21.
- Chan, Y.K., Barraquio, W.L., Knowles, R. (1994) N₂-fixing pseudomonads and related soil bacteria. *FEMS Microbiol Rev* 13: 95-117.
- Coyle, C.L., Zumft, W.G., Kroneck, P.M.H., Körner, H., Jacob, W. (1985) Nitrous oxide reductase from denitrifying *Pseudomonas perfectomarina*. Purification and properties of a novel multicopper enzyme. *Europ J Biochem* 153: 459-467.

- Cosgrove, D.J., P. Bedinger, P., Durachko, D.M. (1997) Group I allergens of grass pollen as cell wall-loosening agents. *Proc. Natl. Acad. Sci. USA* 94: 6559–6564.
- Cosgrove, D. J., Li, L.C., Cho, H.T., Hoffmann-Benning, S., Moore, R.C., Blecker, D. (2002) The growing world of expansins. *Plant Cell Physiol* 43: 1436–1444.
- Cutruzzolà, F. (1999) Bacterial nitric oxide synthesis . *Biochem Biophys Acta* 1411: 231-249.
- Danneberg, G., Kronenberg, A., Neuer, G., Bothe, H. (1985) Aspects of nitrogen fixation and denitrification bt *Azospirillum*. *Plant Soil* 90: 193-202.
- Danneberg, G., Zimmer, W., Bothe: H. (1989) Energy transduction efficiencies in nitrogenous oxide respirations of *Azospirillum brasilense* Sp.7. *Arch Microbiol* 151: 445-453.
- DeMoll-Decker, H., Macy, J.M. (1993). The periplasmic nitrite reductase of *Thauera selenatis* may catalyze the reduction of selenite to elemental selenium. *Arch Microbiol* 160: 241–247.
- De Vos, P., Van Landschoot, A., Segers, P., Tytgat, R., Gillis, M., Bawens, M., Rossau, R., Goor, M., Pot, B., Kersters, K., Lizzaraga, P., De Ley, J. (1989) Genotypic relationships and taxonomic localization of unclassified *Pseudomonas* and *Pseudomonas*-like strains by deoxyribonucleic acid: ribosomal ribonucleic acid hybridizations. *Int J Syst Bacteriol* 39: 35-49.
- Dodd, F.E., Hasnain, S.S., Abraham, Z.H.L., Ready, R.R., Smith, B.E. (1997) Structure of a blue-copper nitrite reductase and its substrate-bound complex. *Acta Crystallogr Sect D* 53: 406-418.

- Dodd, F.E., van Beeumen, J., Eady, R.R., Hasnain, S.S. (1998) X-ray structure of a blue-copper nitrite reductase in two crystal forms. The nature of the copper sites, mode of substrate binding and recognition by redox partner. *J Mol Biol* 282: 369-382.
- Doran, J.W. (1982) Microorganisms and biological cycling of selenium. *Adv Microbial Ecol* 6: 17-32.
- Dower, W., Miller, J.F., Ragsdale, C.W. (1998) High efficiency transformation of the *E. coli* by high voltage electroporation. *Nucl Acid Res* 16: 6127-6145.
- Dungan, R.S., Frankenberger, W.T.J. (1999) Microbial transformations of selenium and the bioremediation of seleniferous environments. *Bioremediation J* 3: 171-88.
- Dunstan, R.H., Kelley, B.C., Nicholas, D.J.D. (1982) Fixation of dinitrogen derived from denitrification of nitrate in a photosynthetic bacterium, *Rhodospseudomonas sphaeroides* forma sp. *denitrificans*. *J Bacteriol* 150: 100-104.
- Einsle, O., Kroneck, P.M. (2004) Structural basis of denitrification. *Biol Chem* 385: 875-883.
- Farabaugh, J.P. (1978) Sequence of the *lacI* gene. *Nature* 274-765.
- Favre-Bonte, S., Ranjard, L., Colinon, C., Prigent-Combaret, C., Nazaret, S., Cournoyer, B. (2005) Freshwater selenium-methylating bacterial thiopurine methyltransferases: diversity and molecular phylogeny. *Environ Microbiol* 7: 153-64.
- Frankenberger, W.T., Karlson, U. in: W.T Frankenberger, S. Benson (eds.) Selenium in the environment, Marcel Dekker, New York, 1994, p. 369.
- Frunzke, K., Meyer, O. (1990) Nitrate respiration, denitrification and utilization of nitrogen sources by aerobic carbon monoxide- oxidizing bacteria. *Arch Microbiol* 154: 168-174.

- Gadd, G.M. (1993) Microbial formation and transformation of organometallic and organometalloid compounds. *FEMS Microbiol Rev* 11: 297-316.
- Gage, D.J. (2004) Infection and invasion of roots by symbiotic, nitrogen-fixing rhizobia during nodulation of temperate legumes. *Microbiol Molec Biol Rev* 68(2): 280-300.
- Ganther, H.E., Levander, O.A., Sauman, C.A. (1966) Dietary control of selenium volatilization in the rat. *J Nutr* 88: 55-60.
- Garcia-Plazaola, J.I., Becerril, J.M., Arrese-Igor, C., Gonzales-Murua, C., Aparicio-Tejo, P.M. (1993) Denitrifying ability of thirteen *Rhizobium meliloti* strains. *Plant and Soil* 157: 207-213.
- Garcin, E., Vernede, X., Hatchikian, E.C., Volbeda, A., Frey, M., Fontecilla-Camps, J.C. (1999) The crystal structure of a reduced [NiFeSe] hydrogenase provides an image of the activated catalytic center. *Struct Fold Des* 7: 557-66.
- Gattow, G., Heinrich, G. (1964) Thermochemistry of selenium. II. Conversion of crystalline selenium modification. III. Conversion of amorphous selenium modifications. *Z Anorg Allg Chem* 331: 256-288.
- Geering, H.R., Cary, E.E., Jones, L.H.P., Allaway, W.H. (1968) Solubility and redox criteria for the possible forms of selenium in soils. *Soil Sci Soc Am Proc* 32: 35-40.
- Godden, J. W., Turley, S., Teller, D.C., Adman, E.T., Liu, M.Y., Payne, W.J., LeGall, J. (1991) The 2.3 angstrom X-ray structure of nitrite reductase from *Achromobacter cycloclastes*. *Science* 253: 438-442.
- Goretski, J., Hollocher, T.C. (1988) Trapping of nitric oxide produced during denitrification by extracellular haemoglobin. *J Biol Chem* 263: 2316-2323.

- Hamdi, Y.A. (1968) Reduction of sodium tellurite by different strains of *Agrobacterium* and *Rhizobium*. *Acta Microbiol Pol* 17: 203-206.
- Heider, J., Böck, A. (1993) Selenium metabolism in microorganisms. *Adv Physiol* 35: 74-107.
- Herbel, M.J., Switzer Blum, J., Oremland, R.S., Borglin, S.E. (2003) Reduction of elemental selenium to selenide: experiments with anoxic sediments and bacteria that respire Se-oxyanions. *Geomicrobiol J* 20: 587-602.
- Hernandez, D., Rowe, J.J. (1988) Oxygen inhibition of nitrate uptake is a general regulatory mechanism in nitrate respiration. *J Biol Chem* 263: 7937-7939.
- Hiraishi, A., Ueda, Y. (1994) Intrageneric structure of the genus *Rhodobacter*: transfer of *Rhodobacter sulfidophilus* and related marine species to the genus *Rhodovulum* gen. nov. *Int J Syst Bacteriol* 44: 15-23.
- Honisch, U., Zumft, W.G. (2003) Operon structure and regulation of the *nos* gene region of *Pseudomonas stutzeri*, encoding an ABC-Type ATPase for maturation of nitrous oxide reductase. *J Bacteriol* 185(6): 1895-1902.
- Huber, R., Wilharm, T., Huber, D., Trincone, A., Burggraf, S., König, H., Rachel, R., Rockinger, I., Fricke, H., Stetter, K.O. (1992) *Aquifex pyrophilus* gen. nov., represent a novel group of marine hyperthermophilic hydrogen-oxidizing bacteria. *Syst Appl Microbiol* 15: 340-351.
- Hughes, M.N. (1999) Relationship between nitric oxide, nitroxyl ion, nitrosonium cation and peroxyxynitrite. *Biochem et Biophys Acta* 1411: 263-272.
- Hunter, W.J., Kuykendall, L.D. (2007) Reduction of selenite to elemental red selenium by *Rhizobium* sp. strain B1. *Curr Microbiol* 55: 344-349.

- Ingraham, J. L. (1981) Microbiology and genetics of denitrifiers. Pages 45-65 in C. C. Delwiche ed. *Denitrification, Nitrification, and Atmosphere Nitrous Oxide*. Wiley-Interscience, New York.
- Keen, N T., Tamaki, S., Kobayashi, D., Trollinger, D. (1988) Improved broad-host range plasmid for DNA cloning in Gram-negative bacteria. *Gene* 70: 191-197.
- Kessi, J. (2006) Enzymatic systems proposed to be involved in the dissimilatory reduction of selenite in the purple non sulfur bacteria *Rhodospirillum rubrum* and *Rhodobacter capsulatus*. *Microbiol* 152: 731-743.
- Kinkle, B.K., Sadowsky, M.J., Johnstone, K., Koskinen, W.C. (1994) Tellurium and selenium resistance in rhizobia and its potential use for direct isolation of *Rhizobium meliloti* from soil. *Appl Environ Microbiol* 60: 1674-1677.
- Krafft, T., Bowen, A., Theis, F., Macy, J.M. (2000) Cloning and sequencing of the genes encoding the periplasmic-cytochrome *b*-containing selenate reductase of *Thauera selenatis*. *DNA Sequation* 10: 365-77.
- Kukimoto, M., Nishiyama, M., Murphy, M.E.P., Turley, S., Adman, E.T., Horinouchi, S., Beppu, T. (1994) X-ray structure and site-directed mutagenesis of a nitrite reductase from *Alcaligenes faecalis* S-6: role of two copper atoms in nitrite reduction. *Biochem* 33: 5246-5252.
- Laemmli, U.K. (1970) Cleavage of structural proteins during the assembly of the head of bacteriophage T4. *Nature* (London) 227: 680-685.
- Lin, J.T., Goldman, B.S., Stewart, V. (1994) The *nasFEDCBA* operon for nitrate and nitrite assimilation in *Klebsiella pneumoniae* M5a1. *J Bacteriol* 176: 2551-2559.

- Linder, K., Oliver, J.D. (1989) Membrane fatty acid and virulence changes in the viable but not culturable state of *Vibrio vulnificus*. *Appl Environ Microbiol* 55: 2837-2842.
- Maher, M.J., Santini, J., Pickering, I.J., Prince, R.C., Macy, J.M., George, G.N. (2004) X-ray absorption spectroscopy of selenate reductase. *Inorg Chem* 43: 402-4.
- Meyer, O., Frunzke, K., Gadkari, D., Jacobitz, S., Hugendieck, I., Kraut, M. (1990) Utilization of carbon monoxide by aerobes: recent advances. *FEMS Microbiol Rev* 87: 253-260.
- Miller, J. (1972) Experiments in Molecular Genetics, p. 352-355. Cold Spring Harbor Laboratory, NY.
- McCarty, S., Chasteen, T., Marshall, M., Fall, R., Bachofen, R. (1993) Phototrophic bacteria produce volatile, methylated sulfur and selenium compounds. *FEMS Microbiol Lett* 112: 93-98.
- McDougald, D., Rice, S.A., Weichart, D., Kjelleberg, S. (1998) Nonculturability: adaptation or debilitation? *FEMS Microbiol Ecol* 25:1-9.
- McGovern, V.P., Oliver, J.D. (1995) Induction of cold-responsive proteins in *Vibrio vulnificus*. *J Bacteriol* 177: 4131-4133.
- Moore, M.D., Kaplan, S. (1992) Identification of intrinsic high-level resistance to rare-earth oxides and oxyanions in members of the class Proteobacteria: characterization of tellurite, SeIV, and rhodium sesquioxidic reduction in *Rhodobacter sphaeroides*. *J Bacteriol* 174: 1505-1514.
- Muckopadhyay, P., Zheng, M., Bedzyk, L.A., LaRossa, R.A., Storz, G. (2004) Prominent roles of the NorR and Fur regulators in the *Escherichia coli* transcriptional response to

reactive nitrogen species. *Proceedings of the National Academy of Science* 101: 745-750.

Mukamolova, G.V., Kormer, S.S., Yanopolskaya, N.D., Kaprelyants, A.S. (1995) Properties of dormant cells in stationary-phase cultures of *Micrococcus luteus* during prolonged incubations. *Mikrobiologiya* 64: 284-288.

Nicholls, D.G., Ferguson, S.J. (2002) *Bioenergetics* 3, Academic Press, London/San Diego.

O'Hara, G.M., Daniel, R.M. (1985) Rhizobial denitrification: A review. *Soil Biol Biochem* 17:1-9.

Ohlendorf, H.M. (1989) Bioaccumulation and effects of selenium in wildlife. P. 133-177 in L. W. Jacobs (ed.), *Selenium in agriculture and the environment*. American Society of Agronomy, Madison, Wis.

Oliver, J.D. (1993) Formation of viable but nonculturable cells. In: *Starvation of bacteria*, Kjelleberg, S. (ed.). Plenum Press, New York, pp. 239-272.

Oliver, J.D., Hite, F., McDougald, D., Andon, N.L., Simpson, L.M. (1995) Entry into, and resuscitation from, the viable but nonculturable state by *Vibrio vulnificus* in an estuarine environment. *Appl Environ Microbiol* 61: 2624-2630.

Oremland, R.S., Zehr, J.P. (1986) Formation of methane and carbon dioxide from dimethylselenide in anoxic sediments and by a methanogenic bacterium. *Appl Environ Microbiol* 52: 1031-36.

Payne, W. J. (1981) *Denitrification*. Wiley-Interscience, New York.

Penfold, R. J. and Pemberton, M. (1992) An improved suicide vector for construction of chromosomal insertion mutations in bacteria. *Gene* 118: 145-146.

- Pinsent, J. (1954) Need for selenite and molybdate in the formation of formic dehydrogenase by members of the *Escherichia coli*-*Aerobacter aerogenes* group of bacteria. *Biochem J* 57:10-16
- Plotnikov, V.I. (1958) coprecipitation of small quantities of selenium with ferric hydroxide. *Zh Neog Klim* 3: 1761-1766.
- Poole, R.K. (2005) Nitric oxide and nitrosative stress tolerance in bacteria. *Biochem Soc Trans* 33(1): 176-180.
- Ranjard, L., Prigent-Combaret, C., Nazaret, S., Cournoyer, B. (2002) Methylation of inorganic and organic selenium by the bacterial thiopurine methyltransferase. *J Bacteriol* 184: 3146-49.
- Ranjard, L., Nazaret, S., Cournoyer, B. (2003) Freshwater bacteria can methylate selenium through the thiopurine methyltransferase pathway. *Appl. Environ. Microbiol.* 69: 3784-90.
- Ranjard, L., Prigent-Combaret, C., Favre-Bonte, S., Monnez, C., Nazaret, S., Cournoyer, B. (2004) Characterization of a novel selenium methyltransferase from freshwater bacteria showing strong similarities with the calicheamicin methyltransferase. *Biochem Biophys Acta* 1679: 80-85.
- Rozsak, D.B., Colwell, R.R. (1987) Survival strategies of bacteria in the natural environments. *Microbiol Rev* 51: 365-379.
- Rozen, S., Skaletsky, H.J. (1998) Primer3 Code available at <http://www.genome.wi.mit.edu/genomesoftware/other/primer3.html>

- Sabaty, M., Avazeri, C., Pignol, D., Vermiglio, A. (2001) Characterization of the reduction of selenate and tellurite by nitrate reductase. *Appl Environ Microbiol* 67(11): 5122-5126.
- Sambrook, J., Fritsch, E.F., Maniatis, T. (1989) *Molecular Cloning: A Laboratory Manual*, second ed., Cold Spring Harbor Laboratory Press, Cold Spring Harbor.
- Samuelsson, M.O. (1985) Dissimilatory nitrate reduction to nitrite, nitrous oxide and ammonium by *Pseudomonas putrefaciens*. *Appl Environ Microbiol* 50: 812-815.
- Satoh, T., Hoshino, Y., Kitamura, H. (1976) *Rhodopseudomonas sphaeroides* forma sp. *denitrificans*, a denitrifying strain as a subspecies of *Rhodopseudomonas sphaeroides*. *Arch Microbiol* 108: 265-269.
- Sayato, Y., Nakamuro, K., Hasegawa, T. (1997) Selenium methylation and toxicity mechanism of selenocysteine. *Yakugaku Zasshi* 117: 665-72.
- Sias, S.R., Stouthamer, A.H., Ingraham, J.L. (1980) The assimilatory and dissimilatory nitrate reductase of *Pseudomonas aeruginosa* are encoded by different genes. *J Gen Microbiol* 118: 229-234.
- Shrift, A. (1973) Metabolism of selenium by plants and microorganisms, in: D.L. Klayman e W.H. Gunther (eds.) *Organic selenium compounds: their chemistry and biology*, pp. 763-814, John Wiley & Sons, New York.
- Smil, V. (1999) Nitrogen in crop production: An account of global flows. *Global Biogeochem Cycles* 13: 647-662.
- Schröder, I., Rech, S., Krafft, T., Macy, J.M. (1997) Purification and characterization of the selenate reductase from *Thauera selenatis*. *J Biol Chem* 272: 23765-68.

- Snyder, S.W., Hollocher, T.C. (1987) Purification and some characteristics of nitrous oxide reductase from *Paracoccus denitrificans*. *J Biol Chem* 262:6515-6525.
- de Souza, M.P., Lytle, C.M., Mulholland, M.M., Otte, M.L., Terry, N. (2000) Selenium assimilation and volatilization from dimethylselenoniopropionate by Indian mustard. *Plant Physiol* 122: 1281-88.
- Squartini, A., Struffi, P., Doering, H., Selenska-Pobell, S., Tola, E., Giacomini, A., Vendramin, E., Velasquez, E., Mateos, P., Martinez-Molina, E., Dazzo, F.B., Casella, S., Nuti, M.P. (2002) *Rhizobium sullae* sp. nov. (formerly *Rhizobium 'hedysari'*): the root-nodule microsymbiont of *Hedysarum coronarium* L. *Int J Syst Evol Microbiol* 52: 1267-1276.
- Stewart, V., Parales, J. (1988) Identification and expression of genes and *narX* of the *narc* (nitrate reductase) locus in *Escherichia coli* K-12. *J Bacteriol* 170: 1589-1597.
- Stolz, J.F., Oremland, R.S. (1999) Bacterial respiration of arsenic and selenium. *FEMS Microbiol Rev* 23: 615-27.
- Storz, G., Hengge-Aronis, R. (2000) Bacterial stress responses. ASM Press, NY, pp 485.
- Strange, R.W., Dodd, F.E., Abraham, Z.H.L., Grossmann, J.G., Brüser, T., Eady, R.R., Smith, B.E., Hasnain, S.S. (1995) The substrate-binding site in Cu nitrite reductase and its similarity to Zn carbonic anhydrase. *Nat Struct Biol* 2(4): 287-292.
- Straub, K.L., Benz, M., Schink, B., Widdel, F. (1996) Anaerobic, nitrate- dependent microbial oxidation of ferrous iron. *Appl Environ Microbiol* 62: 1458-1460.
- Strous, M., Fuerst, J.A., Kramer, E.H., Logemann, S., Muyzer, G., van de Pas-Schoonen, K.T., Webb, R., Kuenen, J.G., Jetten, M.S.M. (1999) Missing lithotroph identified as new planctomycetes. *Nature* 400: 446-449.

- Switzer Blum, J., Bindi, A.B., Buzzelli, J., Stolz, J.F., Oremland, R.S. (1998) *Bacillus arsenoselenatis* sp. nov., and *Bacillus selenitireducens* sp. nov.: two haloalkaliphiles from Mono Lake, California, which respire oxyanions of selenium and arsenic. *Arch Microbiol* 171: 19-30.
- Takai, K., Kobayashi, H., Nealson, K.H., Horikoshi, K. (2003) *Deferribacter desulfuricans* sp. nov., a novel sulfur-, nitrate- and arsenate-reducing thermophile isolated from a deep-sea hydrothermal vent. *Int J Syst Evol Microbiol* 53: 839-46.
- Tavares, P., Pereira, A.S., Moura, J.J.G., Moura, I. (2006) Metalloenzyme of denitrification pathway. *J Inorg Biochem* 100: 2087-2100.
- Toffanin, A., Wu, Q., Maskus, M., Casella, S., Abruña, H.D., Shapleigh, J.P. (1996) Characterization of the gene encoding nitrite reductase and the physiological consequences of its expression in the non-denitrifying *Rhizobium "hedysari"* strain HCNT1. *Appl Environ Microbiol* 62: 4019-4025.
- Toffanin, A., Basaglia, M., Ciardi, C., Vian, P., Povo, S., Casella, S. (2000) Energy content decrease and viable-but-not-culturable status induced by oxygen limitation coupled to the presence of nitrogen oxides in *Rhizobium "hedysari"*. *Biol Fertil Soil* 31: 484-488.
- Trutko, S.M., Akimenko, V.K., Suzina, N.E., Anisimova, L.A., Shlyapnikov, M.G., Baskunov, B.P. (2000) Involvement of the respiratory chain of gram-negative bacteria in the reduction of tellurite. *Arch Microbiol* 173: 178-186.
- Turner, R.J., Weiner, J.H., Taylor, D.E. (1998) Selenium metabolism in *Escherichia coli*. *Biometals* 11: 223-27.
- Van den Bosch, K. A., Bradley, D.J., Knox, J.P., Perotto, S., Butcher, G.W., Brewin, N.J. (1989) Common components of the infection thread matrix and intercellular space

identified by immunocytochemical analysis of pea nodules and uninfected roots. *EMBO J.* 8: 335–342.

Van de Graaf, A.A., Mulder, A., Debruijn, P., Jetten, M.S.M., Robertson, L.A., Kuenen, J.G. (1995) Anaerobic oxidation of ammonium is a biologically mediated process. *Appl Environ Microbiol* 61: 1246-1251.

van Spronsen, P.C., Bakhuizen, R., van Brussel, A.A.N., Kijne, J.W. (1994) Cell-wall degradation during infection thread formation by the rootnodule bacterium *Rhizobium leguminosarum* is a 2-step process. *Eur J Cell Biol* 64: 88-94.

van Workum, W.A.T., van Slageren, S., van Brussel, A.A.N., Kijne, J.W. (1998) Role of exopolysaccharides of *Rhizobium leguminosarum* bv. *viciae* as host plant-specific molecules required for infection thread formation during nodulation of *Vicia sativa*. *Mol Plant-Microbe Interact* 11: 1233-1241.

Völkl, P., Huber, R., Drobner, E., Rachel, R., Burggraf, S., Trincone, A., Stetter, K.O. (1993) *Pyrobaculum aerophilum* sp. nov., a novel nitrate -reducing hyperthermophilic archaeum. *Appl Environ Microbiol* 59: 2918-2926.

Warnecke-Eberz, U., Friedrich, B. (1993) Three nitrate reductase activities in *Alcaligenes eutrophus*. *Arch Microbiol* 159: 405-409.

Weichart, D., Kjelleberg, S. (1996) Stress resistance and recovery potential of culturable and viable but not culturable cells of *Vibrio vulnificus*. *Microbiol* 142: 845-853.

Whanger, P.D. (2004) Selenium and its relationship with cancer: an update. *Br J Nutr* 91: 11-28.

- White, C., Sayer, J.A., Badd, G.M. (1997) Microbial solubilization and immobilization of toxic metals: key biogeochemical processes for treatment of contamination. *FEMS Microbiol Rev* 20: 503-516.
- Wientjes, F.B., Kolk, A.H.J., Nanninga, N., van't Riet, J. (1979) Respiratory nitrate reductase: its localization in the cytoplasmic membrane of *Klebsiella aerogenes* and *Bacillus licheniformis*. *Eur J Biochem* 95: 61-67.
- Yamaguchi, K., Takaota, K., Kobayashi, M., Itoh, K., Fukui, A., Suzuki, S. (2004) Characterization of the two type 1 Cu sites of *Hyphomicrobium denitrificans* nitrite reductase: a new class of a copper -containing nitrite reductase. *Biochem* 43: 14180-14188.
- Yan, T., Fields, M.W., Wu, L., Zu, Y., Tiedje, J.M., Zhou, J. (2003) Molecular diversity and characterization of nitrite reductase gene fragments (*nirK* and *nirS*) from nitrate- and uranium- contaminated groundwater. *Environ Microbiol* 5(1): 13-24.
- Young, J.M., Kuykendall, L.D., Martinez-Romero, E., Kerr, A., Sawada, H. (2001) A revision of *Rhizobium* Frank 1889, with an emended description of the genus, and the inclusion of all species of *Agrobacterium* Conn 1942 and *Allorhizobium undicola* de Lajudie *et al.* 1998 as a new combinations: *Rhizobium radiobacter*, *R. rhizogenes*, *R. rubi*, *R. undicola* and *R. vitis*. *Int J Syst Evol Microbiol* 51: 89-103.
- Young, J.M., Kuykendall, L.D., Martinez-Romero, E., Kerr, A., Sawada, H. (2003) Classification and nomenclature of *Agrobacterium* and *Rhizobium* - a reply to Farrand *et al.*, (2003). *Int J Syst Evol Microbiol* 53: 1689-1695.
- Zhou, J., Fries, M.R., Chee-Sanford, J.C., Tiedje, J.M. (1995) Phylogenetic analyses of a new group of denitrifiers capable of anaerobic growth on toluene and description of *Azoarcus tolulyticus* sp. nov. *Int J Syst Bacteriol* 45: 500-506.

Zieve, R., Ansell, P.J., Young, T.W.K. (1985) *Trans Br Mycol Soc* 84: 177.

Zumft, W.G., Viebrock, A., Korner, H. (1988) In: Cole, J.A. and Ferguson, S.J. (eds) *The Nitrogen and Sulphur Cycles*, pp. 245-279. Cambridge University Press, Cambridge.

Zumft, W.G. (1992) The denitrifying prokaryotes. In: Balows A, Truper H.G., Dworkin M., Harder W., Schleifer K.H. (eds) *The prokaryotes*, 2nd edn, Vol 1 (pp 554-582). Springer Verlag, New York.

Zumft, W.G., Korner, H. (1997) Enzyme diversity and mosaic gene organization in denitrification. *Antonie van Leeuwenhoek* 71: 43-58.

Zumft, W.G. (1997) Cell biology and molecular basis of denitrification. *Microbiol Mol Biol Rev* 61: 533-616.

Appendix

Basaglia, M., Toffanin A., Baldan E., Bottegal M., Shapleigh J.P., Casella, S.

Selenite-reducing capacity of the copper-containing nitrite
reductase of *Rhizobium sllae*

Selenite-reducing capacity of the copper-containing nitrite reductase of *Rhizobium sulae*

Marina Basaglia¹, Annita Toffanin², Enrico Baldan¹, Mariangela Bottegal¹, James P. Shapleigh³ & Sergio Casella¹

¹Dipartimento di Biotecnologie Agrarie, University of Padova, Agripolis, Legnaro, Padova, Italy; ²Dipartimento di Biologia delle Piante Agrarie, University of Pisa, Pisa, Italy; and ³Department of Microbiology, Cornell University, Ithaca, NY, USA

Correspondence: Sergio Casella, Dipartimento di Biotecnologie Agrarie, Agripolis-Università di Padova, Viale dell'Università, 16, 35020 Legnaro, Padova, Italy. Tel.: +0 498 272 922 (926) (925); fax: +0 498 272 929; e-mail: sergio.casella@unipd.it

Received 19 September 2006; revised 9 December 2006; accepted 12 December 2006.

DOI:10.1111/j.1574-6968.2006.00617.x

Editor: Jeff Cole

Keywords

nitrite reductase; selenite reduction; *Rhizobium sulae*.

Introduction

Bacteria belonging to the genera *Rhizobium*, *Allorhizobium*, *Azorhizobium*, *Mesorhizobium*, *Sinorhizobium* and *Bradyrhizobium* are able to interact symbiotically with legume plants to produce nitrogen-fixing root nodules. While some traits are common among all rhizobia, selected traits such as denitrification and the dissimilatory reduction of nitrate to gaseous nitrogen oxides seem to be randomly distributed. Some species are complete denitrifiers, for example *Bradyrhizobium japonicum* (Bedmar *et al.*, 2005), while others are only partial nitrogen oxide-reducers, for example, strains of *Rhizobium sulae* (Casella *et al.*, 1986). While the evolutionary advantage deriving from the complete denitrification pathway may be easily explained, the advantage gained from expressing only a fragment of this pathway has not been completely clarified.

A good example of fragmentation of the denitrification pathway is given by *R. sulae* strain HCNT1, formerly *Rhizobium 'hedysari'*, a nitrogen-fixing bacterium that induces symbiotic nodule formation on the legume *Hedysar-*

Abstract

Rhizobium sulae strain HCNT1 contains a nitric oxide-producing nitrite reductase of unknown function due to the absence of a complementary nitric oxide reductase. HCNT1 had the ability to grow on selenite concentrations as high as 50 mM, and during growth, selenite was reduced to the less toxic elemental selenium. An HCNT1 mutant lacking nitrite reductase grew poorly in the presence of 5 mM selenite, was unable to grow in the presence of 25 or 50 mM selenite and also showed no evidence of selenite reduction. A naturally occurring nitrite reductase-deficient *R. sulae* strain, CC1335, also showed little growth on the higher concentrations of selenite. Mobilization of a plasmid containing the HCNT1 gene encoding nitrite reductase into CC1335 increased its resistance to selenite. To confirm that this ability to grow in the presence of high concentrations of selenite correlated with nitrite reductase activity, a new nitrite reductase-containing strain was isolated from the same location where HCNT1 was isolated. This strain was also resistant to high concentrations of selenite. Inactivation of the gene encoding nitrite reductase in this strain increased selenite sensitivity. These data suggest that the nitrite reductase of *R. sulae* provides resistance to selenite and offers an explanation for the radically truncated denitrification found uniquely in this bacterium.

um coronarium (Casella *et al.*, 1984; Squartini *et al.*, 1993; Struffi *et al.*, 1998; Squartini *et al.*, 2002). This bacterium has been shown to contain a copper-containing nitrite reductase (Casella *et al.*, 1986, 1988; Casella, 1988), which is closely related to the nitric oxide (NO)-generating nitrite reductases of true denitrifiers. Expression of the gene encoding nitrite reductase, *nirK*, is atypical among related denitrifiers in that it does not require the presence of a nitrogen oxide, but only requires a decrease in oxygen concentration (below 16.5% air saturation). Reduction of nitrite by the HCNT1 strain results in the cessation of growth. Insertional inactivation of *nirK* eliminated the nitrite-dependent growth inhibition observed under low oxygen conditions, demonstrating that the NO produced by nitrite reductase is the cause of the growth inhibition (Toffanin *et al.*, 1996). Measurement of NO levels during nitrite reduction demonstrated that NO accumulated to levels that could cause growth inhibition. These results suggest that there is no nitric oxide reductase activity (Nor) in this bacterium as nitrite does not inhibit growth unless provided at extremely high concentrations nor does NO accumulate in denitrifiers that have both Nir

and Nor. Attempts to detect the presence of a Nor structural gene in HCNT1 using a PCR-based approach failed, consistent with the absence of NO reductase (Basaglia *et al.*, 2004). There is no nitrate reductase activity in HCNT1 as there is no inhibition of oxygen uptake if nitrate is added to the medium (Casella *et al.*, 1986). There was also no evidence consistent with the presence of an N₂O reductase. *Rhizobium sullae* strain HCNT1 is therefore an exceptional bacterium due to the radical truncation of its denitrification electron transport chain, having only one of the four terminal reductases required for complete denitrification.

One advantage that could be expected from the possession of Nir is that free-living HCNT1 can conserve energy via the respiration of nitrite. However, no obvious bioenergetic benefit was detected as a consequence of nitrite respiration because HCNT1 could not grow under low oxygen conditions in nitrite-containing medium (Casella *et al.*, 1986). As nitrite reductase expression only occurs under microoxic conditions, nitrite reduction in HCNT1 may be a nitrite detoxification strategy during intranodular life to protect nitrogenase and leghaemoglobin. However, given that a more toxic compound is produced when the nitrite is reduced, the nitrite detoxification hypothesis seems unlikely (Basaglia *et al.*, 2004). Comparisons of nodulation efficiency, plant growth and nitrogen fixation have not revealed any significant differences between wild type and nitrite reductase-deficient strains of HCNT1 under any of the conditions tested so far. It has also been observed that naturally occurring strains of *R. sullae* that lack Nir such as strain CC1335 can nodulate and fix nitrogen at the same level as HCNT1 (Casella *et al.*, 1984). Recent studies have also investigated whether nitrite reductase activity is used as a strategy to reduce the energy content in the bacterial cell in order to induce dormancy (Toffanin *et al.*, 2000; Casella *et al.*, 2001; Basaglia *et al.*, 2007). Taken together, these results do not provide any obvious explanation as to why *R. sullae* contains such a truncated denitrification chain.

The experiments described here were undertaken to determine whether nitrite reductase may play a physiological role unrelated to nitrogen oxide reduction. Previous work has suggested that a dissimilatory nitrite reductase in *Thauera selenatis* is also a selenite reductase (DeMoll-Decker & Macy, 1993). It has also been reported that the reduction of selenite and selenate to Se⁰ can occur under microaerophilic/anaerobic conditions (Turner *et al.*, 1998; Bebien *et al.*, 2002). For example, selenite is respired anaerobically in bacteria such as *Bacillus arsicoselectans*, *Bacillus selenitireducens* and *Sulfospirillum barnesii* (Rathgeber *et al.*, 2002). Therefore, the ability of HCNT1 to reduce selenite was investigated and evidence is presented indicating that expression of *nirK* is linked to selenite reductase activity in *R. sullae*.

Materials and methods

Bacterial strains and growth conditions

The strains used in this work are reported in Table 1. Starter cultures of all strains used were grown aerobically in 250-mL Erlenmeyer flasks containing 150 mL YM broth at 30 °C under shaking.

Plate growth with selenite

Aliquots of cultures grown in YM broth were transferred to YM agar containing 5, 25 and 50 mM Na₂SeO₃. Plates were incubated aerobically at 30 °C and after 48-h growth, the appearance of red colonies was considered to indicate that selenite was reduced to Se⁰ (Moore & Kaplan, 1992; Sabaty *et al.*, 2001).

Sensitivity of bacterial strains to selenite in liquid culture

The sensitivity to selenite was investigated in liquid culture with 5, 25 and 50 mM Na₂SeO₃. Growth was carried out aerobically at 30 °C with agitation in 100 mL Erlenmeyer flasks containing 50 mL YM broth. The flasks were inoculated with 100 µL of late log phase cells. Growth was measured by monitoring the OD of the culture at 600 nm.

Reduction of selenite under different incubation conditions

The cells used as the inoculum in all cases were from a late log phase aerobic starter culture. The experimental samples were prepared in two different ways: (i) 30 mL of the starter culture was centrifuged at 5000 g for 10 min, washed with 0.9% saline solution and inoculated into 250-mL bottles

Table 1. List of plasmids and strains used in this study

Strains or plasmids	Relevant genotype or phenotype	Source or reference
<i>R. sullae</i> HCNT1	Wild type, Nir ⁺	Casella <i>et al.</i> (1986)
<i>R. sullae</i> CC1335	Wild type, Nir ⁻	Casella <i>et al.</i> (1988)
<i>R. sullae</i> A4	Wild type, Nir ⁺	This work
<i>R. sullae</i> HCAT2	Km ^r ; <i>nirK</i> interrupted by a single crossover of pAT3	Toffanin <i>et al.</i> (1996)
<i>R. sullae</i> CC1335 <i>nirK</i>	Tcr Nir ⁺ ; pRKAT7	Toffanin <i>et al.</i> (1996)
<i>R. sullae</i> A4 <i>nirK</i> ⁻	Km ^r ; <i>nirK</i> interrupted by a single crossover of pAT3	This work
PRKAT7	Tc ^r <i>nirK</i> ; ~2,9-kb BamHI-PstI fragment in pRK415	Toffanin <i>et al.</i> (1996)
pAT707	Tc ^r Km ^r ; <i>nirK-lacZ</i> in pRK415	Toffanin <i>et al.</i> (1996)
pAT3	Km ^r ; ~0,6-kb internal <i>nirK</i> fragment generated by PCR in pJP5603	Toffanin <i>et al.</i> (1996)

containing 125 mL YM. The flasks were then sealed with rubber stoppers and the headspace was flushed aseptically with a gas mixture of 5% O₂ and 95% N₂ (v/v). After 48-h incubations, the cells had reduced the available oxygen and consequently had Nir activity. The incubation was continued anaerobically or aerobically, in either saline or YM. When necessary, anaerobic conditions were maintained during the change of media. Aerobic conditions were achieved by replacing the rubber stopper with a foam stopper and agitation of the culture. For these experiments, sterile Na₂SeO₃ was added to give a final concentration of 25 mM. The appearance of a red colour indicating selenite reduction was monitored visually. Incubations were carried out at 30 °C on three replicate bottles for each condition. (ii) Thirty millilitres of the starter culture was centrifuged at 5000 g for 10 min, washed and resuspended with 0.9% saline solution or YM broth to a final OD_{600 nm} of 0.5. Eight mL aliquots of the cell suspensions were incubated either aerobically or under strictly anaerobic conditions. Sterile Na₂SeO₃ was added at the start of the incubation to a final concentration of 25 mM. The presence or absence of a red colour in the broth was recorded after incubation at 30 °C within 24–48 h.

Strain construction

Inactivation of *nirK* in *R. sullivanii* strain A4 was carried out using plasmid pAT7 (Toffanin *et al.*, 1996), which was

moved into A4 by conjugation. S-17-1 was the *Escherichia coli* donor strain in biparental matings. Exconjugants were isolated on minimal medium to prevent the growth of *E. coli*. The introduction of *nirK* into wild-type *R. sullivanii* CC1335 utilized plasmid pRKAT7, a derivative of pRK415 (Keen *et al.*, 1988) carrying the *R. sullivanii* HCNT1 *nirK* gene (Toffanin *et al.*, 1996). The plasmid was moved into recipient strains by biparental matings using *E. coli* S17-1 as the donor strain. Exconjugants were isolated on *Rhizobium* minimal medium (Rm) (O'Gara & Shanmugan, 1976) containing 5 µg mL⁻¹ Tc.

Results and discussion

While examining various rhizobial strains for the capacity to reduce selenite, it was observed that selenite reduction was often concomitant with nitrite reduction in strains of *R. sullivanii*. This was the case with *R. sullivanii* strain HCNT1. This strain is able to reduce nitrite to NO gas once *nirK* has been induced through incubation under oxygen limitation. However, HCNT1 is unable to grow at the expense of nitrite as an electron acceptor (Casella *et al.*, 1986; Toffanin *et al.*, 1996). Cells of HCNT1 grown on medium containing 5–50 mM selenite turned red, consistent with selenite being reduced to Se⁰ (Fig. 1b). The reduction of selenite was also tested in the presence of 1, 5 and 10 mM nitrite. The production of the red elemental selenium was similar to that observed in the absence of nitrite (data not shown).

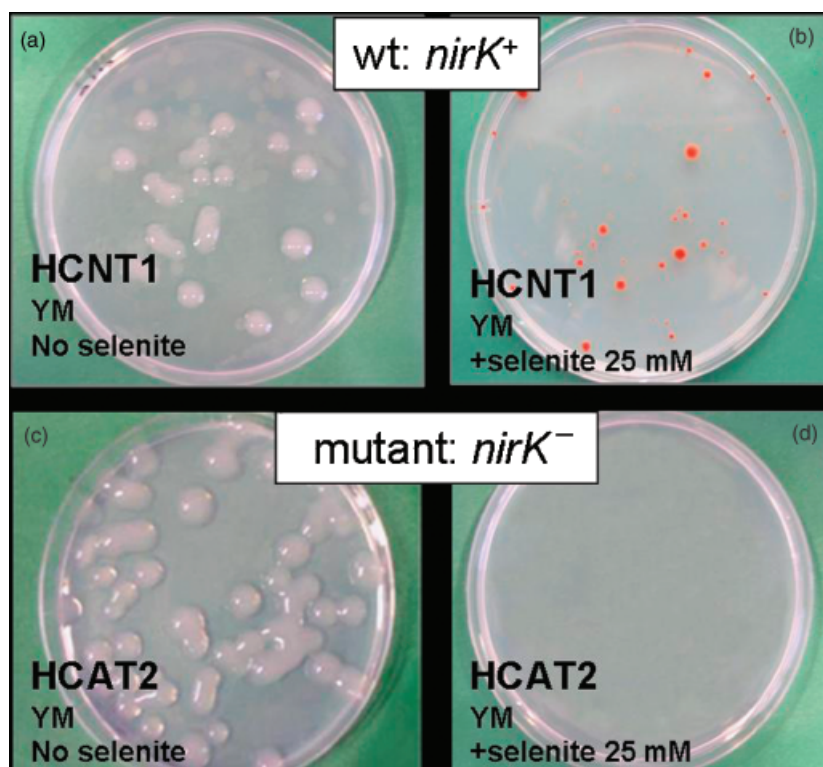

Fig. 1. Wild-type strain HCNT1 grown on YM (a), on YM plus 25 mM selenite (b) and *nirK*⁻ mutant strain HCAT2 on YM (c), on YM containing 25 mM selenite (d).

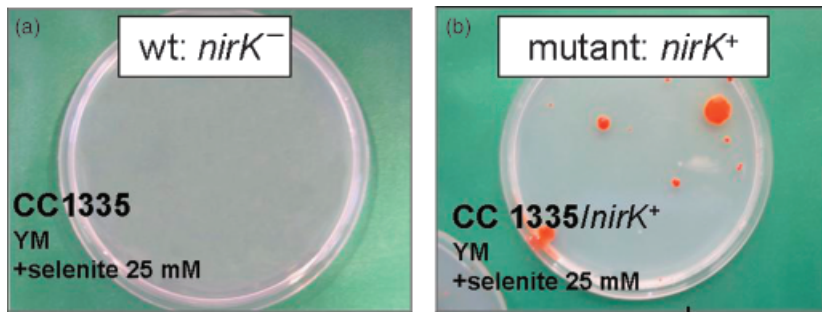

Fig. 2. Wild-type strain CC1335 grown on YM plus 25 mM selenite (a) and *nirK*⁺ mutant strain CC1335/*nirK*⁺ on YM containing 25 mM selenite (b).

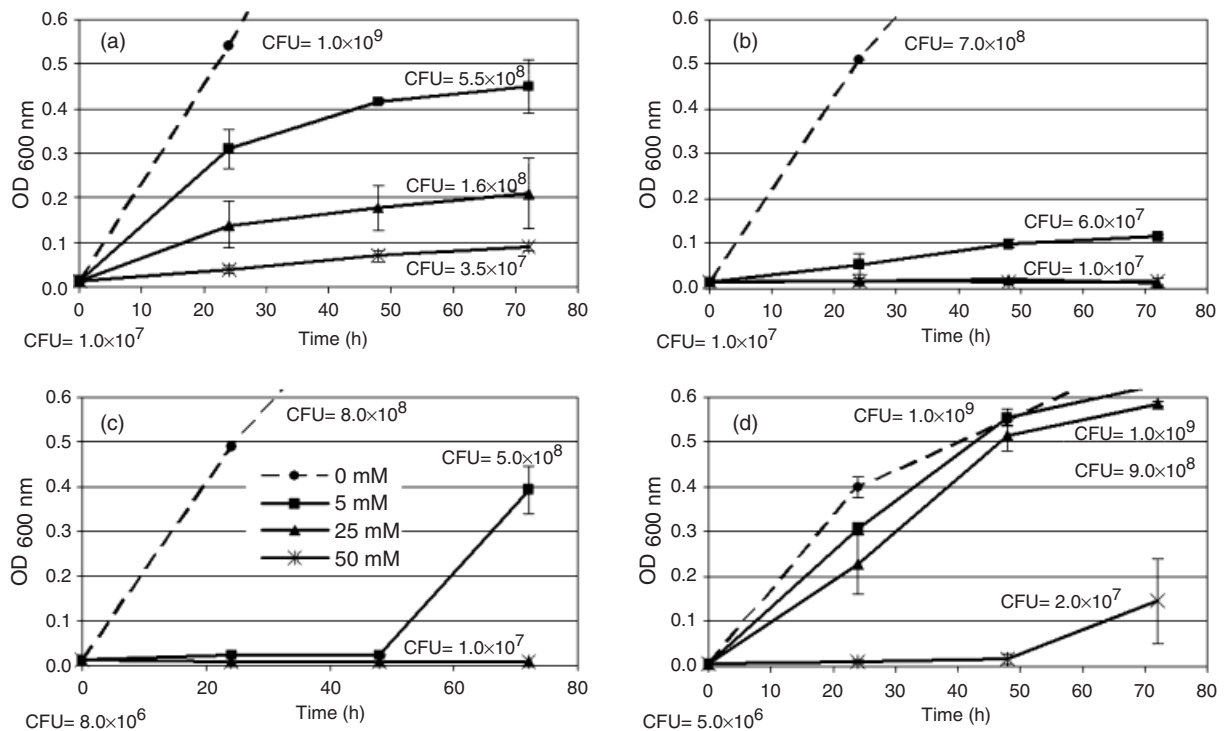

Fig. 3. Liquid cultures of *Rhizobium sulae* strains HCNT1 (a), HCAT2 (b), CC1335 (c) and CC1335/*nirK* (d) in the presence of different concentrations of selenite. CFU are reported in the graphic at the start and final time and represent the means of three replicates.

To test whether selenite reduction in strain HCNT1 is associated with Nir activity, the ability of strain HCAT2 to reduce selenite was tested. This strain is nitrite reductase deficient due to insertional inactivation of *nirK* (Toffanin *et al.*, 1996). Surprisingly, the mutant strain did not grow on any of the selenite-containing media (Fig. 1d).

To further test the role of the *nirK* product in selenite reduction, the ability of the *R. sulae* strain CC1335 to grow on selenite was tested. This strain was chosen because it is naturally *nirK* deficient. When grown on 5 mM selenite, the culture showed a pale shade of red (data not shown). However, unlike HCNT1, this strain was unable to grow on media containing 25 or 50 mM selenite (Fig. 2a). To

determine whether *nirK* could allow growth on higher concentrations of selenite, the selenite resistance of CC1335/*nirK* was tested. CC1335/*nirK* is a strain that contains *nirK* from HCNT1 in trans and can reduce nitrite to NO (Toffanin *et al.* 1996). Like HCNT1, strain CC1335/*nirK* grew on solid medium containing up to 50 mM selenite. During growth, the cells became red, indicating that selenite is being reduced to elemental selenium (Fig. 2b). These results demonstrate that the presence of *nirK* is required for the growth of *R. sulae* on high concentrations of selenite. The appearance of a red colour in the strains with *nirK* indicates that nitrite reductase activity is reducing the selenite to the less toxic elemental selenium.

To assess the impact of selenite on cell growth more accurately, the ability of the various strains to grow in liquid culture with 5, 25 and 50 mM selenite was tested. Figure 3a shows that strain HCNT1 could grow in concentrations of selenite up to 50 mM; however, growth was slowed as the concentrations of selenite increased. During growth of HCNT1, the appearance of a red colour in the medium indicated that selenite was being reduced to elemental selenium. As expected, the Nir-deficient strain HCAT2 showed only limited growth in the presence of the 5 mM selenite and no growth at higher concentrations (Fig. 3b).

The growth of strain CC1335 was much slower than that of HCNT1 in 5 mM selenite. No growth was observed in media with concentrations of 25 or 50 mM selenite. This pattern is similar to HCAT2, with the exception that there was some adaptation to the 5 mM selenite after prolonged incubation (Fig. 3c). In contrast, strain CC1335/*nirK* grew well even at 5 and 25 mM selenite but showed only weak growth at 50 mM (Fig. 3d). The growth observed at 5 and 25 mM selenite was higher than that of HCNT1. This may be due to an increased copy number of *nirK* in CC1335/*nirK*.

Nitrite reduction to NO gas in HCNT1 occurs only after exposure of cells to oxygen-limiting conditions. To test whether exposure to low oxygen correlates with the ability to reduce selenite, cells of HCNT1 and HCAT2 were

incubated under different oxygen regimes and the reduction of 25 mM selenite was recorded by the appearance of a red colour. When cells were preincubated under low oxygen conditions, which will induce *nirK* expression, HCNT1 reduced selenite but HCAT2 did not (Table 2). Unexpectedly, cells of HCNT1 that were not exposed to low oxygen conditions were also able to reduce selenite. HCAT2 was unable to reduce selenite under this treatment, indicating that the observed activity requires *nirK* expression. The selenite resistance phenotype requires a rich medium as cells incubated in saline media did not produce the red colour indicative of selenite reduction (Table 2).

Strain HCNT1 was originally isolated in a soil containing moderately high concentrations of selenium. The average selenium concentration was measured by ICP to be 1–2 mg kg⁻¹ d.m.; however, samples from this site show a high variability, making it possible that some locations could have significantly higher concentrations. To provide additional support for a connection between Nir activity and cell viability and growth in this environment, another series of isolations was carried out for *R. sultae* from the same location from which HCNT1 was isolated. A strain with characteristics similar to HCNT1 was readily isolated. This strain, designated A4, was found to contain *nirK* by Southern hybridization analysis of genomic DNA (data not shown). Cells grown under low oxygen conditions had Nir activity as indicated by the disappearance of nitrite in the presence of the artificial electron donor methyl viologen (Stewart & Parales 1988; Toffanin *et al.*, 1996).

As shown in Fig. 4a, strain A4 also demonstrated selenite reduction activity, producing red colonies on agar dishes containing 25 mM selenite. A Nir-deficient strain of A4 was then obtained by *nirK* inactivation, generating strain A4*nirK*⁻. This mutant was unable to reduce nitrite, making it phenotypically equivalent to HCAT2. As with HCNT1, inactivation of *nirK* also prevented growth on selenite (Fig. 4b), further supporting the role of Nir in selenite resistance and reduction. A comparison of the nodulation score and nitrogen fixation levels obtained with wild type and Nir-deficient strains on *H. coronarium* plants did not indicate any significant differences (data not shown).

Table 2. Selenite reduction of strain HCNT1 and its *nirK*-minus mutant strain HCAT2 under different incubation conditions

	After incubation under <i>nirK</i> inducing conditions	Aerobic culture
HCNT1		
Aerobic + YMB	+++	+++
Aerobic + Saline	---	---
Anaerobic + YMB	+++	+++
Anaerobic+ Saline	---	---
HCAT2		
Aerobic + YMB	---	---
Aerobic + Saline	---	---
Anaerobic + YMB	---	---
Anaerobic+ Saline	---	---

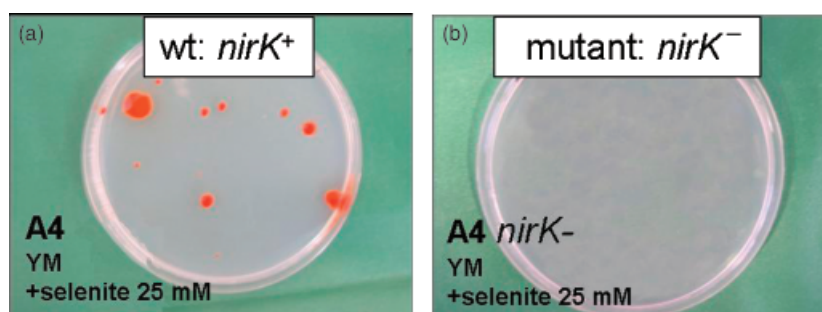

Fig. 4. Wild-type strain A4 (a) and its *nirK*⁻ mutant strain (b) grown on YM plus 25 mM selenite.

Rhizobium sullae strain HCNT1 and the newly isolated A4 strain do not obtain any obvious energetic benefit from their radically truncated denitrification chain (Casella et al., 2006). However, the observation that this trait is stable enough to allow the isolation of strain A4 about twenty years after isolation of HCNT1 suggests that this trait provides some selectable benefit. As these strains are the only two described to date that stably tolerate a NO-producing Nir in spite of the absence of Nor activity, this phenotype may be uniquely associated with the environment from which they originated. Measurements have shown that the soil from which these strains were isolated is relatively rich in selenite. These results indicate that Nir may be one of the selenite resistance mechanisms used by *R. sullae*. Nir seems to be most important when selenite concentrations are in the mM level. There appear to be other mechanisms of resistance that can be used to lower levels of selenite, as found in other *Alphaproteobacteria* (Kessi et al., 1999; Kessi, 2006). The persistence of Nir in *R. sullae*, despite the absence of Nor, along with its novel regulation suggests that bacteria in this environment may encounter microsites where selenium concentrations are high enough to require an additional level of resistance. This would explain why Nir is conserved in bacteria living in these soils and represents a novel use of this enzyme.

Acknowledgements

This work was supported by Grant MIURex40% and is part of EU-COST Action 856.

References

- Basaglia M, Toffanin A, Shapleigh JP, Baldan E & Casella S (2004) Elucidating the cause and effect of NO accumulation in *R. Sullae* strain HCNT1. *Cost Action 856: Ecological Aspects of Denitrification with Emphasis on Agriculture* (Bothe et al., eds), pp. 56. Marburg, Germany.
- Basaglia M, Povoletto S & Casella S (2007) Effect of oxygen and host plant on resuscitation of viable not culturable *Sinorhizobium meliloti* 41. *Curr Microbiol* DOI: 10.1007/s00284-005-0482-3.
- Bebien M, Lagniel G, Garin J, Touati D, Vermeglio A & Labarre J (2002) Involvement of superoxide dismutases in the response of *Escherichia coli* to selenium oxides. *J Bacteriol* **184**: 1556–1564.
- Bedmar EJ, Robles EF & Delgado MJ (2005) The complete denitrification pathway of the symbiotic, nitrogen-fixing bacterium *Bradyrhizobium japonicum*. *Biochem Soc Trans* **33**: 141–144.
- Casella S (1988) Positive and negative aspects of denitrification in Rhizobium-legume associations. *Physiological Limitation and the Genetic Improvement of Symbiotic Nitrogen Fixation* (O' Gara, et al., eds), pp. 117–125. Kluwer Academic Publishers, Dordrecht, The Netherlands.
- Casella S, Gault RR, Reynolds KC, Dyson JR & Brockwell J (1984) Nodulation studies on legume exotic to Australia: *Hedysarum coronarium* L. *FEMS Microbiol Lett* **22**: 37–45.
- Casella S, Shapleigh JP & Payne WJ (1986) Nitrite reduction in *Rhizobium 'hedysari'* strain HCNT1. *Arch Microbiol* **146**: 233–238.
- Casella S, Shapleigh JP, Lupi F & Payne WJ (1988) Nitrite reductase in bacteroids of *Rhizobium 'hedysari'* strain HCNT1. *Arch Microbiol* **149**: 384–388.
- Casella S, Fontana F, Povoletto S & Basaglia M (2001) VBNC induction and resuscitation of *Sinorhizobium meliloti* strain 41. *9th International Symposium on Microbial Ecology, Interactions in the Microbial World*, pp. 191. Amsterdam, The Netherlands.
- Casella S, Shapleigh JP, Toffanin A & Basaglia M (2006) Investigation into the role of the truncated denitrification chain in *Rhizobium sullae* strain HCNT1. *Biochem Soc Transaction* **34**: 130–132.
- DeMoll-Decker H & Macy JM (1993) The periplasmic nitrite reductase of *Thauera selenatis* may catalyze the reduction of selenite to elemental selenium. *Arch Microbiol* **160**: 241–247.
- Keen NT, Tamaki S, Kobayashi D & Trollinger D (1988) Improved broad-host-range plasmids for DNA cloning in gram-negative bacteria. *Gene* **70**: 191–197.
- Kessi J (2006) Enzymic systems proposed to be involved in the dissimilatory reduction of selenite in the purple non-sulfur bacteria *Rhodospirillum rubrum* and *Rhodobacter capsulatus*. *Microbiology* **152**: 731–743.
- Kessi J, Ramuz M, Wehrli E, Spycher M & Bachofen R (1999) Reduction of selenite and detoxification of elemental selenium by the phototrophic bacterium *Rhodospirillum rubrum*. *Appl Environ Microbiol* **65**: 4734–4740.
- Moore MD & Kaplan S (1992) Identification of intrinsic high-level resistance to rare-earth oxides and oxyanions in members of the class *Proteobacteria*: characterisation of tellurite, SeIV, and rhodium sesquioxides reduction in *Rhodobacter sphaeroides*. *J Bacteriol* **174**: 1505–1514.
- O' Gara F & Shanmugan KT (1976) Regulation of nitrogen fixation by Rhizobia: export of fixed N₂ as NH₄⁺. *Biochim Biophys Acta* **437**: 313–321.
- Rathgeber C, Yurkova N, Stackebrandt E, Beatty JT & Yurkov V (2002) Isolation of tellurite- and selenite-resistant bacteria from hydrothermal vents of the Juan de Fuca Ridge in the Pacific Ocean. *Appl Environ Microbiol* **68**: 4613–4622.
- Sabaty M, Avazeri C, Pignol D & Vermeglio A (2001) Characterization of the reduction of selenate and tellurite by nitrate reductase. *Appl Environ Microbiol* **67**: 5122–5126.
- Squartini A, Dazzo FB, Casella S & Nuti MP (1993) The root nodule symbiosis between *Rhizobium 'hedysari'* and its drought-tolerant host *Hedysarum coronarium*. *Symbiosis* **15**: 227–238.
- Squartini A, Struffi P, Doering H et al. (2002) *Rhizobium sullae* sp. Nov. (formerly *Rhizobium 'hedysari'*): the root-nodule microsymbiont of *Hedysarum coronarium* L. *Int J Syst Evol Microbiol* **52**: 1267–1276.

- Stewart V & Parales J Jr (1988) Identification and expression of genes *narI* and *narX* of the *nar* (nitrate reductase) locus in *Escherichia coli* K-12. *J Bacteriol* **170**: 1589–1597.
- Struffi P, Corich V, Giacomini A, Benguedouar A, Squartini A, Casella S & Nuti MP (1998) Metabolic properties, stress tolerance and macromolecular profiles of rhizobia nodulating *Hedysarum coronarium*. *J Appl Bacteriol* **84**: 81–89.
- Toffanin A, Wu Q, Maskus M, Casella S, Abrunã HD & Shapleigh JP (1996) Characterization of the gene encoding nitrite reductase and the physiological consequences of its expression in the non-denitrifying *Rhizobium 'hedysari'* strain HCNT1. *Appl Environ Microbiol* **62**: 4019–4025.
- Toffanin A, Basaglia M, Ciardi C, Vian P, Povoletto S & Casella S (2000) Energy content decrease and viable-not-culturable status induced by oxygen limitation coupled to the presence of nitrogen oxides in *Rhizobium 'hedysari'*. *Biol Fertil Soils* **31**: 484–488.
- Turner RJ, Weiner JH & Taylor DE (1998) Selenium metabolism in *Escherichia coli*. *Biometals* **11**: 223–227.

General acknowledgements

There are many people I wish to gratefully acknowledge for these years of my PhD.

First I would like to thank my supervisors Professor Sergio Casella and Professor Marina Basaglia, who gave me the opportunity to carry out my PhD in their research group.

I would like to extend special thanks to Dr Silvana Povolo. Thanks for your continuous discussions that allowed me to stay on the right way and to learn a lot of things that a researcher must know.

A great thank goes to Dr Federico Fontana, who made the gas-chromatograph analyses.

Thank you for your kind help and support and, above all, for your friendship.

I am very grateful to my colleagues and friends of Microbiology group. Thank to Enrico, Elisa, Barbara, Lorenzo, Elena, Alessandra, Dafni, Sara and Mizan for the good atmosphere in the lab and for the reciprocal support.

Special thanks go also to the Department of Agricultural Biotechnology.

A sincere acknowledgement goes to Professor Andrea Battisti for his kindness with PhD students.

Heartfelt thanks to Simone. You have been so patient with me during the last months. Thank you for your love and your support. You know what else I could say now.

Finally, my gratefulness goes to my family. Many thanks for your continuous support in these years.

I dedicate this thesis to my grandmother Angela. Dear grandma, I always think about you in difficult moments, trying to remember your precious advises and your encouragements you always gave me. Thank you.

Mariangela Bottegal